

# Rotary-Type Positive-Displacement Compressors for Petroleum, Petrochemical, and Natural Gas Industries

API STANDARD 619  
FOURTH EDITION, DECEMBER 2004



.....

# Rotary-Type Positive-Displacement Compressors for Petroleum, Petrochemical, and Natural Gas Industries

Downstream Segment

API STANDARD 619  
FOURTH EDITION, NOVEMBER 2004



## SPECIAL NOTES

API publications necessarily address problems of a general nature. With respect to particular circumstances, local, state, and federal laws and regulations should be reviewed.

API is not undertaking to meet the duties of employers, manufacturers, or suppliers to warn and properly train and equip their employees, and others exposed, concerning health and safety risks and precautions, nor undertaking their obligations under local, state, or federal laws.

Information concerning safety and health risks and proper precautions with respect to particular materials and conditions should be obtained from the employer, the manufacturer or supplier of that material, or the material safety data sheet.

Nothing contained in any API publication is to be construed as granting any right, by implication or otherwise, for the manufacture, sale, or use of any method, apparatus, or product covered by letters patent. Neither should anything contained in the publication be construed as insuring anyone against liability for infringement of letters patent.

Generally, API standards are reviewed and revised, reaffirmed, or withdrawn at least every five years. Sometimes a one-time extension of up to two years will be added to this review cycle. This publication will no longer be in effect five years after its publication date as an operative API standard or, where an extension has been granted, upon republication. Status of the publication can be ascertained from the API Standards department telephone (202) 682-8000. A catalog of API publications, programs and services is published annually and updated biannually by API, and available through Global Engineering Documents, 15 Inverness Way East, M/S C303B, Englewood, CO 80112-5776.

This document was produced under API standardization procedures that ensure appropriate notification and participation in the developmental process and is designated as an API standard. Questions concerning the interpretation of the content of this standard or comments and questions concerning the procedures under which this standard was developed should be directed in writing to the Director of the Standards department, American Petroleum Institute, 1220 L Street, N.W., Washington, D.C. 20005. [standards@api.org](mailto:standards@api.org) Requests for permission to reproduce or translate all or any part of the material published herein should be addressed to the Director, Business Services.

API standards are published to facilitate the broad availability of proven, sound engineering and operating practices. These standards are not intended to obviate the need for applying sound engineering judgment regarding when and where these standards should be utilized. The formulation and publication of API standards is not intended in any way to inhibit anyone from using any other practices.

Any manufacturer marking equipment or materials in conformance with the marking requirements of an API standard is solely responsible for complying with all the applicable requirements of that standard. API does not represent, warrant, or guarantee that such products do in fact conform to the applicable API standard.

*All rights reserved. No part of this work may be reproduced, stored in a retrieval system, or transmitted by any means, electronic, mechanical, photocopying, recording, or otherwise, without prior written permission from the publisher. Contact the Publisher, API Publishing Services, 1220 L Street, N.W., Washington, D.C. 20005.*

Copyright © 2004 American Petroleum Institute

## IMPORTANT INFORMATION CONCERNING USE OF ASBESTOS OR ALTERNATIVE MATERIALS

Asbestos is specified or referenced for certain components of the equipment described in some API standards. It has been of extreme usefulness in minimizing fire hazards associated with petroleum processing. It has also been a universal sealing material, compatible with most refining fluid services.

Certain serious adverse health effects are associated with asbestos, among them the serious and often fatal diseases of lung cancer, asbestosis, and mesothelioma (a cancer of the chest and abdominal linings). The degree of exposure to asbestos varies with the product and the work practices involved.

Consult the most recent edition of the Occupational Safety and Health Administration (OSHA), U.S. Department of Labor, Occupational Safety and Health Standard for Asbestos, Tremolite, Anthophyllite, and Actinolite, 29 *Code of Federal Regulations* Section 1910.1001; the U.S. Environmental Protection Agency, National Emission Standard for Asbestos, 40 *Code of Federal Regulations* Sections 61.140 through 61.156; and the U.S. Environmental Protection Agency (EPA) rule on labeling requirements and phased banning of asbestos products (Sections 763.160-179).

There are currently in use and under development a number of substitute materials to replace asbestos in certain applications. Manufacturers and users are encouraged to develop and use effective substitute materials that can meet the specifications for, and operating requirements of, the equipment to which they would apply.

SAFETY AND HEALTH INFORMATION WITH RESPECT TO PARTICULAR PRODUCTS OR MATERIALS CAN BE OBTAINED FROM THE EMPLOYER, THE MANUFACTURER OR SUPPLIER OF THAT PRODUCT OR MATERIAL, OR THE MATERIAL SAFETY DATA SHEET.



# CONTENTS

Foreword .....	vii
Introduction .....	viii
1 Scope.....	1
2 Normative references .....	2
3 Terms and definitions.....	4
4 General .....	10
4.1 Unit responsibility.....	10
4.2 Nomenclature .....	10
4.3 Dimensions.....	10
4.4 Statutory requirements.....	10
4.5 Alternative designs .....	10
4.6 Conflicting requirements.....	10
5 Basic design .....	10
5.1 General .....	10
5.2 Pressure casing .....	13
5.3 Casing connections .....	15
5.4 External forces and moments.....	17
5.5 Rotating elements .....	17
5.6 Shaft seals .....	18
5.7 Dynamics .....	22
5.8 Bearings .....	25
5.9 Bearing housings.....	28
5.10 Lube-oil and seal-oil systems .....	29
5.11 Materials.....	32
5.12 Nameplates and rotation arrows .....	37
5.13 Quality .....	37
6 Accessories .....	37
6.1 Drivers .....	37
6.2 Couplings and guards .....	38
6.3 Mounting plates.....	39
6.4 Controls and instrumentation.....	41
6.5 Piping .....	46
6.6 Intercoolers and aftercoolers .....	48
6.7 Inlet air filters.....	48
6.8 Inlet separators .....	49
6.9 Pulsation suppressors/silencers for dry screw compressors .....	49
6.10 Special tools .....	51
7 Inspection, testing, and preparation for shipment.....	51
7.1 General .....	51
7.2 Inspection .....	52
7.3 Testing .....	53
7.4 Preparation for shipment .....	58
8 Vendor's data .....	59
8.1 General .....	59
8.2 Proposals.....	60
8.3 Contract data .....	61

<b>Annex A</b> (normative) <b>Typical data sheets</b> .....	<b>A-1</b>
<b>Annex B</b> (informative) <b>Nomenclature for equipment</b> .....	<b>B-1</b>
<b>Annex C</b> (informative) <b>Forces and moments</b> .....	<b>C-1</b>
<b>Annex D</b> (normative) <b>Procedure for determination of residual unbalance</b> .....	<b>D-1</b>
<b>Annex E</b> (informative) <b>Typical schematics for oil system for flooded screw compressor</b> .....	<b>E-1</b>
<b>Annex F</b> (informative) <b>Materials and their specifications for rotary compressors</b> .....	<b>F-1</b>
<b>Annex G</b> (informative) <b>Mounting plates</b> .....	<b>G-1</b>
<b>Annex H</b> (informative) <b>Inspector’s checklist</b> .....	<b>H-1</b>
<b>Annex I</b> (informative) <b>Typical vendor drawing and data requirements</b> .....	<b>I-1</b>
<b>Bibliography</b> .....	<b>Bib-1</b>



## FOREWORD

This standard is based on the accumulated knowledge and experience of manufacturers and users of rotary-type positive-displacement compressors. The objective of this standard is to provide a purchase specification to facilitate the procurement and manufacture of rotary-type positive-displacement compressors for use in petroleum, chemical, and gas industry services.

The primary purpose of this standard is to establish minimum requirements. This limitation in scope is one of charter as opposed to interest and concern.

Energy conservation is of concern and has become increasingly important in all aspects of equipment design, application, and operation. Thus innovative energy conserving approaches should be aggressively pursued by the manufacturer and the user during these steps. Alternative approaches that may result in improving energy utilization should be thoroughly investigated and brought forth. This is especially true of new equipment proposals, since the evaluation or purchase options will be based increasingly on total life costs as opposed to acquisition cost alone. Equipment manufacturers, in particular, are encouraged to suggest alternatives to those specified when such approaches achieve improved energy effectiveness and reduced total life costs without sacrifice of safety or reliability.

This standard requires the purchaser to specify certain details and features. Although it is recognized that the purchaser may desire to modify, delete, or amplify sections of this standard, it is strongly recommended that such modifications, deletions, and amplifications be made by supplementing this standard, rather than by rewriting or incorporating sections thereof into another standard.

API standards are published as an aid to procurement of standardized equipment and materials. These standards are not intended to inhibit purchasers or producers from purchasing or producing products made to other standards.

API publications may be used by anyone desiring to do so. Every effort has been made by the Institute to assure the accuracy and reliability of the data contained in them; however, the Institute makes no representation, warranty, or guarantee in connection with this publication and hereby expressly disclaims any liability or responsibility for loss or damage resulting from its use or for the violation of any federal, state, or municipal regulation with which this publication may conflict.

Suggested revisions are invited and should be submitted to API, Standards department, 1220 L Street, NW, Washington, DC 20005, standards@api.org.

## INTRODUCTION

Users of this International Standard should be aware that further or differing requirements may be needed for individual applications. This International Standard is not intended to inhibit a vendor from offering, or the purchaser from accepting, alternative equipment or engineering solutions for the individual application. This may be particularly appropriate where there is innovative or developing technology. Where an alternative is offered, the vendor should identify any variations from this International Standard and provide details.

A bullet (●) at the beginning of a paragraph indicates that either a decision is required or further information is to be provided by the purchaser. This information should be indicated on the data sheets; otherwise it should be stated in the quotation request (Inquiry) or in the order.

# Rotary-Type Positive-Displacement Compressors for Petroleum, Petrochemical, and Natural Gas Industries

## 1 Scope

This standard covers the minimum requirements for dry and oil-flooded helical lobe rotary compressors (see Figure 1) used for vacuum or pressure or both in petroleum, petrochemical, and natural gas industries. It is intended for compressors that are in special-purpose applications. It does not cover general purpose air compressors, liquid ring compressors, and vane-type compressors.

Note: Standard air compressors are covered in ISO 10440: *Petroleum and natural gas industries—Rotary-Type Positive-Displacement Compressors Part 2—Packaged air compressors (oil free)*.

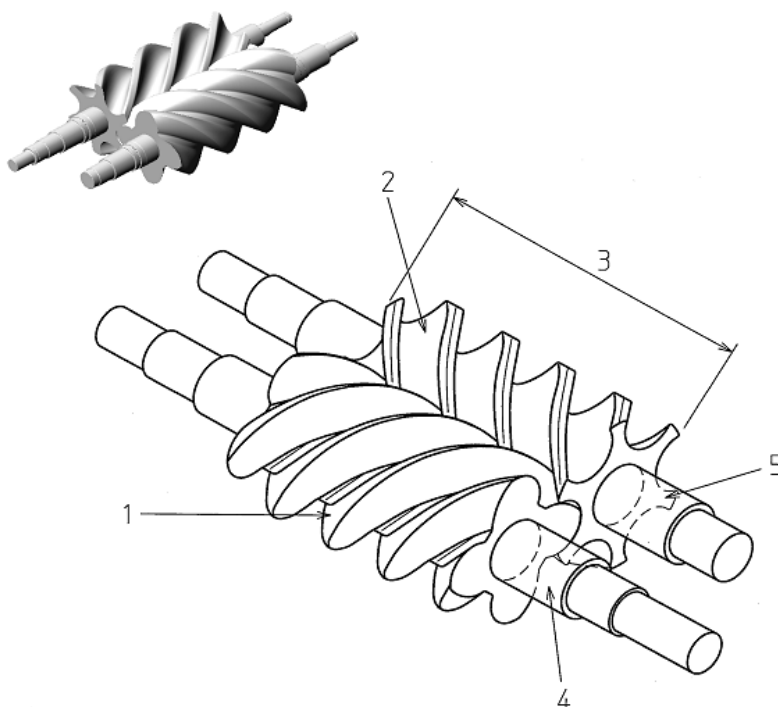

Key:

- 1. Male rotor
- 2. Female rotor
- 3. Rotor body
- 4. Shaft extension—male rotor
- 5. Shaft extension—female rotor

**Figure 1—Helical Compressor Rotors**

## 2 Normative references

2.1 All referenced standards, to the extent specified in the text, are normative.

2.2 Notes following a paragraph are informative.

- 2.3 Where dual referencing of standards occurs, the system of standards to be used shall be specified.

2.4 The following normative documents contain provisions which, through reference in this text, constitute provisions of API 619. For dated references, subsequent amendments to, or revisions of, any of these publications do not apply. However, parties to agreements based on API 619 are encouraged to investigate the possibility of applying the most recent editions of the normative documents indicated below. For undated references, the latest edition of the normative document referred to applies.

ABMA 7, *Shaft, housing fits for metric radial ball & roller bearings (except tapered roller bearings) conforming to basic boundary plans*<sup>1</sup>

ABMA 20, *Radial bearings of ball, cylindrical roller and spherical roller types—Metric design*

AGMA 1328-1, *Cylindrical gears—ISO system of accuracy—Part 1: Definitions and allowable values of deviations relevant to corresponding flanks of gear teeth*<sup>2</sup>

ANSI S2.19, *Balance quality requirements of rigid rotors—Part 1: Determination of permissible residual unbalance*<sup>3</sup>

API RP 500, *Classification of locations for electrical installations at petroleum facilities*<sup>4</sup>

API RP 520, *Sizing, selection and installation of pressure-relieving devices in refineries—Part 1: Sizing and selection*

API Std 526, *Flanged steel pressure relief valves*

API Std 541, *Form-wound squirrel cage induction motors —500 horsepower and larger*

API Std 546, *Brushless synchronous machines—500 kVA and larger*

API Std 611, *General-purpose steam turbines for petroleum, chemical, and gas industry service*

API Std 613, *Special-purpose gear units for petroleum, chemical, and gas industry services*

API Std 614, *Lubrication, shaft-sealing, and control-oil systems and auxiliaries for petroleum, chemical and gas industry services*

API Std 661, *Air cooled heat exchangers for general refinery services*

API Std 670, *Vibration, axial-position, and bearing-temperature monitoring systems*

API Std 671, *Special-purpose couplings for petroleum, chemical and gas industry services*

API Std 677, *General-purpose gear units for petroleum, chemical and gas industry services*

API RP 686, *Machinery installation and installation design*

ASME B1.1, *Unified inch screw threads, UN and UNR thread form*<sup>5</sup>

ASME B16.1, *Cast iron pipe flanges and flanged fittings*

ASME B16.11, *Forged steel fittings, socket-welding and threaded*

ASME B16.42, *Ductile iron pipe flanges and flanged fittings*

ASME B16.47, *Large diameter steel flanges*

<sup>1</sup> American Bearing Manufacturers Association, 2025 M Street, NW, Suite 800, Washington, DC 20036, USA.

<sup>2</sup> American Gear Manufacturers Association, 1500 King Street, Suite 201, Alexandria, VA 22314, USA.

<sup>3</sup> American National Standards Institute, 500 Montgomery Street, Suite 350, Alexandria, VA 22314, USA.

<sup>4</sup> American Petroleum Institute, 1220 L Street NW, Washington, DC 20005-4070, USA.

<sup>5</sup> American Society of Mechanical Engineers, Three Park Avenue, New York, NY 10016-5990, USA.

- ASME B16.5, *Pipe flanges and flanged fittings (steel)*
- ASME B17.1, *Keys and keyseats*
- ASME B31.3, *Process piping*
- ASME Boiler and Pressure vessel code section V, "Nondestructive examination"
- ASME Boiler and Pressure vessel code section VIII, "Pressure vessels"
- ASME Boiler and Pressure vessel code section IX, "Welding and brazing qualifications"
- ASTM A 247, *Standard Test Method for Evaluating the Microstructure of Graphite in Iron Castings*<sup>6</sup>
- ASTM A 278, *Standard Specification for Gray Iron Castings for Pressure-Containing Parts for Temperatures Up to 650 degrees F*
- ASTM A 320, *Standard Specification for Alloy-Steel Bolting Materials for Low-Temperature Service*
- ASTM A 395, *Ferritic Ductile Iron Pressure-retaining Castings for Use at Elevated Temperatures*
- ASTM A 536, *Standard Specification for Ductile Iron Castings*
- ASTM E 94, *Standard guide for radiographic examination*
- ASTM E 709, *Standard guide for magnetic particle examination*
- ASTM E 1003, *Standard Test Method for Hydrostatic Leak Testing*
- AWS D1.1, *Structural welding code—Steel*<sup>7</sup>
- IEC-60079, *Electrical apparatus for explosive gas atmospheres*<sup>8</sup>
- IEEE 841, *Standard for petroleum and chemical industry—Severe duty totally enclosed fan-cooled (TEFC) squirrel cage induction motors—up to and including 370 kW (500 HP)*<sup>9</sup>
- ISO 7, *Pipe threads where pressure-tight joints are made on the threads*<sup>10</sup>
- ISO 261, *ISO general-purpose metric screw threads—General plan*
- ISO 262, *ISO general-purpose metric screw threads—Selected sizes for screws, bolts and nuts*
- ISO 281, *Rolling bearings—Dynamic load ratings and rating life*
- ISO 724, *ISO general-purpose metric screw threads—Basic dimensions*
- ISO 945, *Cast iron—Designation of microstructure of graphite*
- ISO 965, *ISO general-purpose metric screw threads—Tolerances*
- ISO 1217, *Displacement compressors—Acceptance tests*
- ISO 1328-1, *Cylindrical gears—ISO system of accuracy—Part 1: Definitions and allowable values of deviations relevant to corresponding flanks of gear teeth*
- ISO 1940, *Mechanical vibration—Balance quality requirements of rigid rotors—Part 1: Determination of permissible residual unbalance*
- ISO 3448, *Industrial liquid lubricants—ISO viscosity classification*
- ISO 3744, *Acoustics—Determination of sound power levels of noise sources using sound pressure—Engineering method in an essentially free field over a reflecting plane*
- ISO 5753, *Rolling bearings—Radial internal clearance*

<sup>6</sup> American Society for Testing and Materials, 100 Bar Harbor Drive, West Conshohocken, PA 19428-2959, USA.

<sup>7</sup> American Welding Society, 550 North LeJeune Road, Miami, FL 33136, USA.

<sup>8</sup> International Electrotechnical Commission, Central Office, 3, rue de Varembe, P.O. Box 131, CH-1211 Geneve 20, Switzerland.

<sup>9</sup> Institute of Electrical & Electronic Engineers, 445 Hoes Lane, Piscataway, NJ 08855-1331, USA.

<sup>10</sup> International Organization for Standardization, Central Secretariat, 1, rue de Varembe, Case postale 56, CH-1211 Geneve 20, Switzerland.

ISO 6708, *Pipework components—Definition and selection of DN (nominal size)*

ISO 7005-1, *Metallic flanges—Part 1: Steel flanges*

ISO 7005-2, *Metallic flanges—Part 2: Cast iron flanges*

ISO 8821, *Mechanical vibration—Balancing—Shaft and fitment key convention*

ISO 10437, *Petroleum, petrochemical and natural gas industries—Steam turbines—Special-purpose applications*

ISO 10438, *Lubrication, shaft-sealing and control-oil systems for special-purpose applications*

ISO 10441, *Petroleum and natural gas industries—Flexible couplings for mechanical power transmission—Special purpose applications*

ISO 13691, *Petroleum and natural gas industries—High-speed special-purpose gear units*

NACE MR0175, *Sulfide stress-cracking resistant metallic materials for oilfield equipment*<sup>11</sup>

NEMA 250, *Enclosures for Electrical Equipment (1000 Volts Maximum)*<sup>12</sup>

NEMA SM 23, *Steam turbines for mechanical drive service*

NFPA 70, *National electrical code*<sup>13</sup>

TEMA *Standard Class C*<sup>14</sup>

TEMA *Standard Class R*

### 3 Definition of Terms

For the purposes of API 619, the following definitions apply. (See Annex B for a guide to rotary-type positive-displacement compressor nomenclature.)

#### 3.1

##### **alarm point**

A preset value of a measured parameter at which an alarm is actuated to warn of a condition that requires corrective action.

#### 3.2

##### **anchor bolts**

Bolts used to attach the housing plate to the support structure (concrete foundation or steel structure).

Note: Refer to Subclause 3.16 for definition of hold down bolts.

#### 3.3

##### **axially-split**

A joint that is parallel to the shaft centerline.

#### 3.4

##### **baseplate**

A structure providing support and mounting surfaces for one or more pieces of equipment.

#### 3.5

##### **certified point**

The point at which the vendor certifies that the performance is within the tolerances stated in the standard. It is usually the normal operating point.

#### 3.6

##### **critical speed**

A shaft rotational speed at which the rotor-bearing support system is in a state of resonance.

<sup>11</sup> NACE International, The Corrosion Society, 1440 South Creek Drive, Houston, Texas 77084-4906, USA

<sup>12</sup> National Electrical Manufacturers Association, 1300 N. 17th Street, Suite 1847, Rosslyn, VA 22209, USA

<sup>13</sup> National Fire Protection Association, 1 Batterymarch Park, Quincy, MA 02269-9101, USA.

<sup>14</sup> Tubular Exchanger Manufacturers Association, Inc., 25 North Broadway, Tarrytown, NY 10591, USA.

### 3.7

#### **depressurization valve**

A valve, external to the compressor, used to relieve the gas pressure within the compressor or compressor package to atmospheric or flare pressure.

Note: Also known as a blowdown valve.

### 3.8

#### **design**

A term that may be used by the equipment manufacturer to describe various parameters such as design power, design temperature, or design speed.

Note: This terminology should be used only by the equipment manufacturer and not in the purchaser's specifications.

### 3.9

#### **dry screw compressor**

A rotary helical lobe compressor that uses no liquid for sealing the rotor clearances and driving the noncoupled rotor.

Note 1: The rotor-to-rotor relationship is maintained by timing gears on each rotor, and the noncoupled rotor is driven by the coupled rotor through the timing gears.

Note 2: No rotor-to-rotor contact occurs in the dry screw compressor.

### 3.10

#### **fail safe**

A system which will cause the equipment to revert to a permanently safe condition (shutdown and/or depressurized) in the event of a component failure or failure of the energy supply to the system.

### 3.11

#### **flammable fluid**

(Refer to NFPA 30.)

### 3.12

#### **flooded screw compressor**

A rotary, helical lobe compressor with a lubricant (compatible with the process gas) injected into the rotor area after the closed thread position of the rotor.

Note: This lubricant helps seal rotor clearances and establishes an oil film between the rotors. One rotor drives the other in the absence of a timing gear.

### 3.13

#### **gas-oil separator**

A pressure containing device, usually a vessel, used to separate entrained oil from the process gas.

### 3.14

#### **gauge board**

A bracket or plate used to support and display gauges, switches and other instruments. A gauge board is open and not enclosed.

Note: A gauge board is not a panel. A panel is an enclosure. Refer to 3.38 for the definition of a panel.

### 3.15

#### **general-purpose application**

An application that is usually spared or is in non-critical service.

### 3.16

#### **hold down bolts (mounting bolts)**

Bolts holding the equipment to the mounting plate.

### 3.17

#### **hydrodynamic bearings**

Bearings that use the principles of hydrodynamic lubrication. The bearing surfaces are oriented such that relative motion forms an oil wedge or wedges to support the load without shaft-to-bearing contact.

**3.18****informative element**

Describes part of the standard which is provided for information and is intended to assist in the understanding or use of the standard. Compliance with an informative part of the standard is not mandated.

Note: An annex may be informative or normative as indicated.

**3.19****inlet volume flow**

The flow rate expressed in volume flow units at the conditions of pressure, temperature, compressibility, and gas composition, including moisture content, at the compressor inlet flange.

Note: Inlet volume flow is a specific example of actual volume flow. Actual volume flow is the volume flow at any particular location such as interstage or compressor discharge. Actual volume flow should not be used interchangeably with inlet volume flow.

**3.20****inlet separator**

A device, usually a filter or vessel, used to separate entrained solid and liquid contaminants from the process gas inlet steam.

**3.21****local**

Refers to the location of a device when mounted on or near the equipment or console.

**3.22****maximum allowable differential pressure**

The highest differential pressure that can be permitted in the compressor under the most severe operating conditions of minimum suction pressure and discharge pressure equal to the relief valve setting.

**3.23****maximum allowable speed**

The highest rotational speed of the power input rotor at which the manufacturer's design will permit continuous operation.

**3.24****maximum allowable temperature**

The maximum continuous temperature for which the manufacturer has designed the equipment (or any part to which the term is referred) when handling the specified fluid at the specified maximum operating pressure.

**3.25****maximum allowable working pressure**

The maximum continuous pressure for which the manufacturer has designed the equipment (or any part to which the term is referred) when handling the specified fluid at the specified maximum operating temperature.

**3.26****maximum continuous speed**

The highest rotational speed of the power input rotor at which the machine, as built and tested, is capable of continuous operation with the specified fluid at any of the specified operating conditions.

**3.27****maximum power**

The highest power the compressor and any shaft-driven appurtenances require for any of the specified operating conditions, including the effect of any equipment (such as pulsation suppression devices, process piping, intercoolers, after-coolers, and separators) furnished by the compressor vendor.

Note: Deviations from the specified conditions such as relief valve set pressure are excluded from maximum power.

**3.28****maximum sealing pressure**

The highest pressure the seals are required to seal during any specified static or operating condition and during start-up and shutdown.



**3.29**

**minimum allowable speed**

The lowest rotational speed of the power input rotor at which the manufacturer's design will permit continuous operation.

**3.30**

**minimum allowable temperature**

The lowest temperature for which the manufacturer has designed the equipment (or any part to which the term is referred).

**3.31**

**mounting plate**

A device used to attach equipment to concrete foundations. It may be a sole plate, a baseplate or a combination of both.

**3.32**

**normal operating point**

The point at which usual operation is expected and optimum efficiency is desired. This point is usually the certified point.

**3.33**

**normative**

A requirement of the standard.

**3.34**

**observed**

An inspection or test where the purchaser is notified of the timing of the inspection or test and the inspection or test is performed as scheduled if the purchaser or his representative is not present.

Note: Refer to Subclause 3.67 for the definition of witnessed test.

**3.35**

**owner**

The final recipient of the equipment who may delegate another agent as the purchaser of the equipment.

**3.36**

**panel**

An enclosure used to mount, display, and protect gauges, switches, and other instruments.

**3.37**

**pocket passing frequency**

The frequency at which the gas is discharged from the rotor lobes into the discharge port.

Note: Pocket passing frequency (Hz) is calculated by multiplying the rotor rotational speed (revolutions per minute) by the number of lobes on that rotor and dividing the product by 60.

**3.38**

**pressure casing**

The composite of all stationary pressure-containing parts of the unit, including all nozzles and other attached parts.

**3.39**

**purchaser**

The agency that issues the order and specifications to the vendor.

Note: The purchaser may be the owner of the plant in which the equipment is to be installed or the owner's appointed agent.

**3.40**

**radially split**

A joint which is perpendicular to the shaft centerline.

**3.41**

**rated speed (also known as 100% speed)**

The highest rotational speed of the power input rotor required to meet any of the specified operating conditions.

**3.42****relief valve set pressure**

The pressure at which a relief valve starts to lift.

**3.43****remote**

Refers to the location of a device when located away from the equipment or console, typically in a control house.

**3.44****required capacity**

The largest inlet volume required by the specified operating conditions.

**3.45****rotor**

Rotating male or female assembly, including rotor body, shaft and shrunk-on sleeves (when furnished).

Note: See Figure 1.

**3.46****rotor body**

The helical profile section on or integral with the shaft.

**3.47****rotor set**

The set consists of both male and female rotors. and, for dry screw compressors, includes timing gears and thrust collars.

**3.48****seal barrier gas**

A clean gas supplied to the area between the seals of a dual seal arrangement at a pressure higher than the process pressure.

**3.49****seal buffer gas**

Clean gas supplied to the process (inboard) side of a seal.

**3.50****separation seal gas**

A supply of inert gas or air fed into the region between the seal and the shaft bearing or between the bearing housing and atmosphere.

**3.51****settle-out pressure**

The highest pressure which the compressor will experience when not running and after equilibrium has been reached.

Note: this may be a function of ambient temperature, relief valve setting, and piping system volume.

**3.52****shall**

Is used to state a mandatory requirement.

**3.53****shutdown set point**

A preset value of a measured parameter at which automatic or manual shutdown of the system or equipment is required.

**3.54****slide valve**

A device integral to the compression chamber for varying the volumetric flow through a rotary screw compressor.

Note: See Figure B-2.

**3.55****sole plate**

A plate grouted to the foundation, with a mounting surface for equipment or for a baseplate.

**3.56**

**special-purpose application**

An application for which the equipment is designed for uninterrupted continuous operation in critical service, and for which there is usually no installed spare equipment.

**3.57**

**special tool**

A tool which is not a commercially available catalog item.

**3.58**

**standard volume flow**

Is the flow rate expressed in volume flow units at standard conditions as follows:

*ISO Standard Conditions*

Flow: Cubic meters per hour (m<sup>3</sup>/h)  
 Cubic meters per minute (m<sup>3</sup>/min)  
 Pressure: 1.013 bar  
 Temperature: 0°C

*U.S. Standard Conditions*

Flow: Standard cubic feet per minute (scfm)  
 Million standard cubic feet per day (mmscfd)  
 Pressure: 14.7 PSI  
 Temperature: 60°F

Note: The standard volume flow is determined for dry gas.

**3.59**

**standby service**

A normally idle or idling piece of equipment that is capable of immediate automatic or manual start-up and continuous operation.

**3.60**

**thermal relief valve**

A valve for relieving pressure caused by thermal expansion of liquid within a closed volume.

**3.61**

**trip speed**

Is the rotational speed of the power input rotor at which the independent emergency overspeed system operates to shut down a prime mover. For the purposes of this standard, the trip speed of alternating current electric motors, except variable frequency drives, is the speed corresponding to the synchronous speed of the motor at maximum supply frequency.

**3.62**

**unit responsibility**

Refers to the responsibility for coordinating the technical aspects of the equipment and all auxiliary systems included in the scope of the order. It includes responsibility for reviewing such factors as the power requirements, speed, rotation, general arrangement, couplings, dynamics, noise, lubrication, sealing system, material test reports, instrumentation, piping, conformance to specifications and testing of components.

**3.63**

**vendor (also referred to as the supplier)**

The agency that supplies the equipment.

Note: The vendor may be the manufacturer of the equipment or the manufacturer's agent, and normally is responsible for service support.

**3.64**

**witnessed**

An inspection or test where the purchaser is notified of the timing of the inspection or test and a hold is placed on the inspection or test until the purchaser or his representative is in attendance.

## 4 General

### 4.1 Unit responsibility

The vendor who has unit responsibility shall assure that all subvendors comply with the requirements of this standard and all reference documents.

### 4.2 Nomenclature

A guide to API Standard 619 nomenclature can be found in Annex B.

### • 4.3 Units of measurement

The purchaser shall specify whether data, drawings, hardware (including fasteners) and equipment supplied to this standard shall use the SI or US Customary units.

Note: Dedicated Data Sheets for SI units and for US Customary units are provided in Annex A.

### 4.4 Statutory requirements

The purchaser and the vendor shall mutually determine the measures that must be taken to comply with any governmental codes, regulations, ordinances, or rules that are applicable to the equipment.

### 4.5 Alternative designs

The vendor may offer alternative designs.

### 4.6 Conflicting requirements

In case of conflict between this standard and the inquiry the inquiry shall govern. At the time of the order the order shall govern.

## 5 Basic design

### 5.1 General

**5.1.1.** The equipment (including auxiliaries) covered by this standard shall be designed and constructed for a minimum service life of 20 years and at least 3 years of uninterrupted operation.

Note: It is recognized that this is a design criterion.

**5.1.2** The vendor shall assume unit responsibility for all equipment and all auxiliary systems included in the scope of the order.

- **5.1.3** The purchaser shall specify the equipment's normal operating point.
- **5.1.4** The purchaser shall specify all other operating points, including start-up conditions, and shall indicate the certified operating point.
- **5.1.5** The purchaser shall specify the settle-out pressure. In the event this pressure is not available at the time of inquiry, the normal discharge pressure shall be assumed.

Note: If the actual settle-out pressure is higher than the assumed pressure, the seal system, drive train components, relief valves and piping system may be adversely affected.

**5.1.6** Equipment driven by induction motors shall be rated at the actual motor speed for the rated load condition.

**5.1.7** Equipment shall be designed to run without damage to the relief valve set pressure, specified maximum differential pressure, and trip speed (see 5.1.12), simultaneously.

Note 1: There may be insufficient driver power to operate under these conditions.

Note 2: For machines operating with variable suction and discharge pressure levels, maximum allowable temperature can occur before maximum allowable pressure or maximum allowable differential pressure occurs. In such cases the manufacturer and the purchaser should jointly consider and apply suitable safeguarding controls to avoid any damage. Controls may include but are not limited to discharge temperature or differential pressure.

**5.1.8** Unless otherwise specified, cooling water systems shall be designed for the following conditions:

Water velocity over heat exchange surfaces	1.5-2.5 m/s	5-8 ft/s
Maximum allowable working pressure (MAWP)	>7.0 bar (Note 1)	>100 psig
Test pressure (1.5 times MAWP)	>10.5 bar (Note 1)	>150 psig
Maximum pressure drop	1 bar	15 psi
Maximum inlet temperature	32°C	90°F
Maximum outlet temperature	50°C	120°F
Maximum temperature rise	17K	30°R
Minimum temperature rise	10K	20°R
Fouling factor on water side	0.35 m-K/kW	0.002 hr-ft-F/Btu
Shell corrosion allowance	3.0 mm	0.125 in

The vendor shall notify the purchaser if the criteria for minimum temperature rise and velocity over heat exchange surfaces result in a conflict. The criteria for velocity over heat exchange surfaces is intended to minimize water-side fouling; the criterion for minimum temperature rise is intended to minimize the use of cooling water. If such a conflict exists, the purchaser will approve the final selection.

Note 1: Gauge pressure.

**5.1.9** The arrangement of the equipment, including piping and auxiliaries, shall be developed jointly by the purchaser and the vendor. The arrangement shall provide adequate clearance areas and safe access for operation and maintenance.

**5.1.10** All equipment shall be designed to permit rapid and economical maintenance. Major parts such as casing components and bearing housings shall be designed and manufactured to ensure accurate alignment on reassembly. This may be accomplished by the use of shouldering, cylindrical dowels or keys.

**5.1.11** The equipment’s maximum continuous speed shall be not less than 105% of the rated speed for variable speed machines and shall be equal to the rated speed for constant speed motor drives.

**5.1.12** The equipment’s trip speed shall not be less than the values in Table 1.

**5.1.13** Spare and replacement parts for the machine and all furnished auxiliaries shall meet all the criteria of this standard.

**Table 1—Driver Trip Speeds**

Driver Type	Trip Speed (% of maximum continuous speed)
Steam Turbine	
Nema Class A <sup>a</sup>	115%
Nema Class B,C,D <sup>a</sup>	110%
Gas Turbine	105%
Variable Speed Motor	110%
Constant Speed Motor	100%
Reciprocating Engine	110%
<sup>a</sup> Indicates Governor class as specified in NEMA SM 23.	

**5.1.14** Oil reservoirs and housings that enclose moving lubricated parts such as bearings, shaft seals, highly polished parts, instruments, and control elements shall be designed to minimize contamination by moisture, dust, and other foreign matter during periods of operation and idleness.

**5.1.15** The equipment (machine, driver, and ancillary equipment) shall perform on the test stand and on their permanent foundation within the specified acceptance criteria. After installation, the performance of the combined units shall be the joint responsibility of the purchaser and the vendor who has unit responsibility. The performance of the machine shall also take into account the following:

- a) The power at the certified point shall not exceed 104% of the quoted value with no negative tolerance on required capacity.
- b) The compressor vendor shall confirm that the unit is capable of continuous operation at any specified conditions.
- c) If specified, the compressor vendor shall confirm that the unit is capable of start-up at settle-out or elevated suction pressure.
- d) The purchaser shall specify gas composition(s). The purchaser may also specify molecular weight, ratio of specific heats ( $C_p/C_v$ ), and compressibility factor ( $Z$ ).
- e) Unless otherwise specified, the vendor shall use the specified values of flow, the specified gas composition, and the gas conditions to calculate molecular weight, ratio of specific heats ( $C_p/C_v$ ), and compressibility factor ( $Z$ ). The compressor vendor shall indicate his values on the data sheets with the proposal and use them to calculate performance data.
- **5.1.16** If specified, the vendor shall review and comment on the purchaser's piping and foundation drawings.
- **5.1.17** If specified, in order to verify compliance with agreed criteria (such as API Recommended Practice 686 or vendor's standard), the vendor's representative shall witness:
  - a) A check of the piping alignment performed by unfastening the major flanged connections of the equipment.
  - b) The initial shaft alignment check.
  - c) Shaft alignment at operating temperature.

Note: Many factors may adversely affect site performance. These factors include such items as piping loads, alignment at operating conditions, supporting structure, handling during shipment, and handling and assembly at the site.

**5.1.18** Motors, electrical components, and electrical installations shall be suitable for the area classification (class, group, and division or zone) specified by the purchaser and shall meet the requirements of the applicable sections of IEC 60079 or NFPA 70, Articles 500, 501, 502, and 504, as well as any local codes specified and furnished on request by the purchaser. Refer to Clause 2—Normative References for a listing of applicable electrical codes.

- **5.1.19** Control of the sound pressure level (SPL) of all equipment furnished shall be a joint effort of the purchaser and the vendor having unit responsibility. The equipment furnished by the vendor shall conform to the maximum allowable sound pressure level specified. In order to determine compliance, the vendor shall provide both maximum sound pressure and sound power level data per octave band for the equipment.

Note: The sound power level of a source can be treated as a property of that source under a given set of operating conditions. The sound pressure level, however, will vary depending on the environment in which the source is located as well as the distance from the source. Vendors routinely take exception to guaranteeing a purchaser's maximum allowable sound pressure level requirement due to the argument that the vendor has no control over the environment in which the equipment is to be located. The vendor has control, however, over the sound power level of the equipment.

- **5.1.20** If specified, the vendor shall supply acoustical treatment. The type of treatment and safety requirements shall be agreed by the vendor and the purchaser.

Note: These compressors tend to be very noisy. The compressor may require an acoustical enclosure to achieve acceptable noise levels. Such factors as accessibility for operation and maintenance, purge requirements when handling flammable or toxic gas, noise levels within the enclosure, explosion-proof doors, and see-through window requirements for machine monitoring should be considered in the design and construction of acoustical enclosures.

**5.1.21** If equipment for liquid separation in the discharge gas stream is required, the specifications shall be developed jointly by the purchaser and the vendor.

Note: Liquid separation is always required for flooded screw compressors (see 5.10.3.1) and may be required for dry screw compressors if liquid injection is utilized.

- **5.1.22** The equipment, including all auxiliaries, shall be suitable for operation under the environmental conditions specified by the purchaser. These conditions shall include whether the installation is indoors (heated or unheated) or outdoors (with or without a roof), maximum and minimum temperatures, unusual humidity, and dusty or corrosive conditions.
- **5.1.23** The equipment, including all auxiliaries, shall be suitable for operation, using the utility stream conditions specified by the purchaser.

**5.1.24** Bolting shall be furnished as follows:

- a) The details of threading shall conform either to ISO 261, ISO 262, ISO 724, and ISO 965 or to ASME B1.1.
- b) Adequate clearance shall be provided at all bolting locations to permit the use of socket or box wrenches.
- c) Internal socket-type, slotted-nut, or spanner-type bolting shall not be used unless specifically approved by the purchaser.

Note: For limited space locations, integrally flanged fastener may be required.

- d) Manufacturers marking shall be located on all fasteners 6 mm (<sup>1</sup>/<sub>4</sub> in) and larger (excluding washers and headless set screws). For studs, the marking shall be on the nut end of the exposed stud end.

Note: A set screw is a headless screw with an internal hex opening on one end.

- **5.1.25** The purchaser should indicate the presence of solid or liquid particles in the gas stream, and their amount, size and composition.

**5.2 Pressure casing**

**5.2.1** The pressure casing shall be designed in accordance with 5.2.1.1 or 5.2.1.2 as selected by the vendor and the casing joint bolting shall be in accordance with 5.2.1.3 to:

- a) operate without leakage or internal contact between rotating and stationary components while subject simultaneously to the MAWP (and corresponding temperature) and the worst case combination of maximum allowable nozzle loads applied to all nozzles.
- b) withstand the hydrostatic test.

**5.2.1.1** The allowable tensile stress used in the design of the pressure casing (excluding bolting) for any material shall not exceed 0.25 times the minimum ultimate tensile strength for the material at the maximum specified operating temperature. For cast materials, the allowable tensile stress shall be multiplied by the appropriate casting factor as shown in Table 2.

**Table 2—Casting factors**

Type of NDE	Casting factor
Visual, magnetic particle and/or liquid penetrant	0.8
Spot radiography	0.9
Ultrasonic	0.9
Full radiography	1.0

**5.2.1.2** Pressure containing components may be designed with the aid of finite element analysis, provided that the design limits comply with Section VIII division 2 of ASME pressure vessel code (Code) stress intensity as modified by equation 1. Manufacturing data report forms, third party inspections, and stamping as specified in the ASME code are not required.

Equation 1:  $MA SI = CSI(P_{code\ hydro}/150)$

MA SI = maximum allowable stress intensity, kPa (psi).  
 CSI = Code stress intensity, kPa (psi).  
 $P_{Code\ hydrotest}$  = Code hydrotest pressure, percent of MAWP.

The manufacturer shall state the source of the material properties, such as ASTM, as well as the casting factors applied in his proposal.

**5.2.1.3** For casing joint bolting, the allowable tensile stress, as determined in 5.2.1.1 shall be used to determine the total bolting area based on hydrostatic load and gasket preload as applicable. The preload stress shall not exceed 0.75 times the bolting material minimum yield.

Note 1: In general, deflection is the determining consideration in the design of casings. Ultimate tensile or yield strength is seldom the limiting factor.

Note 2: Preloading the bolting is required to prevent unloading the bolted joint due to cyclic operation.

**5.2.2** The maximum allowable working pressure of the casing shall be at least equal to the specified relief valve set pressure. If a relief valve set pressure is not specified by the purchaser, it must be specified by the vendor. (See Notes in 5.1.7)

**5.2.2.1** Unless otherwise specified, for dry screw compressors system pressure protection will be furnished by the purchaser.

**5.2.2.2** For flooded screw compressors the gas system pressure protection will be furnished by the vendor and sized per API Recommended Practice 520 (including fire case) or other criteria as specified by the purchaser.

**5.2.3** Casings shall be made of steel if (a) rated discharge pressure is over 27.5 bar gauge (400 pounds per square inch), or (b) discharge temperature is over 260°C (500°F), or (c) gas is flammable or toxic.

Note: In cases where cast iron casings are acceptable, other considerations such as repair ability of the casing due to close rotor/casing clearances may be a consideration in specifying a steel casing.

**5.2.4** Casings designed for more than one maximum allowable working pressure are not permitted. When a cooling jacket is utilized, this jacket shall have only external connections between the upper and lower housings.

**5.2.5** The main joint of axially split casings shall use a metal-to-metal joint that is tightly maintained by bolting. The joint shall be sealed with a compound that is compatible with the fluids to be handled. Gaskets (including string type) shall not be used. The main joints of radially split casings, may incorporate a gasket. Such gaskets shall be fully confined.

**5.2.6** Each axially split casing shall be sufficiently rigid to allow removal and replacement of its upper half without disturbing rotor-to-casing running clearances.

**5.2.7** Casings and supports shall be designed to have sufficient strength and rigidity to limit any change in the relative position of the shaft ends at the coupling flange, caused by the worst combination of allowable pressure, torque, and piping forces and moments, to 50 µm ( 0.002 in).

**5.2.8** Supports and alignment bolts shall be rigid enough to permit the machine to be moved by the use of its lateral and axial jackscrews.

**5.2.9** Jackscrews, guide rods, casing-alignment dowels and/or other appropriate devices shall be provided to facilitate disassembly and reassembly. Guide rods shall be of sufficient length to prevent damage to the internals or casing studs by the casing during disassembly and reassembly. Lifting lugs or eyebolts shall be provided for lifting only the top half of the casing. Methods of lifting the assembled machine shall be specified by the vendor.

When jackscrews are used as a means of parting contacting faces, one of the faces shall be relieved (counterbored or recessed) to prevent a leaking joint or an improper fit caused by marring of the face.

- **5.2.10** When specified for dry screw compressor corrosion resistance, overlay cladding or plating shall be applied to the casing wall. This procedure may require an overbore of the casing during manufacture prior to final machining.

Note: As an example, for wet CO<sub>2</sub> service (carbonic acid), a stainless overlay 2.5 to 3.2 mm (0.100 to 0.125 in) thick could be applied to the cast steel casing wall. The casing would be overbored to allow for a multilayer weld overlay lining consisting of a barrier pass of Type 308/309 stainless steel followed by a cover pass of 308/316. The casing would be finish machined after the



stainless overlay. The end wall could be lined similarly or have compatible stainless steel end plates provided. The vendor shall include details of this procedure in the casing design proposal.

**5.2.11** In addition to the requirements of 5.1.24, pressure casing bolting shall be furnished as specified in 5.2.11.1 and 5.2.11.2.

**5.2.11.1** Studs shall be supplied on the main joint of axially split casings and bolted end covers of radially split casings, unless cap screws are specifically approved by the purchaser.

Studs shall be used instead of cap screws, on all other joints, except where hexagonal head cap screws are essential for assembly purposes and have been approved by the purchaser.

Note: Flooded screw compressors are typically designed to use cap screws.

- **5.2.11.2** If specified, the main casing joint studs and nuts shall be designed for the use of hydraulic bolt tensioning. Procedures and extent of special tooling provided by the vendor shall be mutually agreed upon.

**5.2.12** The use of threaded holes in pressure parts shall be minimized. To prevent leakage in pressure sections of casings, metal equal in thickness to at least half the nominal bolt diameter, in addition to the allowance for corrosion, shall be left around and below the bottom of drilled and threaded holes. The depth of the threaded holes shall be at least 1.5 times the stud diameter.

**5.2.13** Mounting surfaces shall meet the following criteria:

1. They shall be machined to a finish of 6.3  $\mu\text{m}$  (250  $\mu\text{in}$ ) arithmetic average roughness (Ra) or better.
2. To prevent a soft foot, they shall be in the same horizontal plane within 25  $\mu\text{m}$  (0.001 in).
3. Each mounting surface shall be machined within a flatness of 13  $\mu\text{m}$  per 330 linear millimeters (0.0005 inches per linear foot) of mounting surface.
4. Different mounting planes shall be parallel to each other within 50  $\mu\text{m}$  (0.002 in).
5. The upper machined or spot faced surface shall be parallel to the mounting surface.

Hold-down bolt holes shall be drilled perpendicular to the mounting surface or surfaces, and, to allow for equipment alignment, be 13 mm (0.5 in) larger in diameter than the hold down bolt. If spot faced, its diameter shall be three times that of the bolt hole.

**5.2.14** The equipment feet shall be provided with vertical jackscrews and shall be drilled with pilot holes that are accessible for use in final doweling.

### 5.3 Casing connections

**5.3.1** All openings or nozzles for piping connections on pressure casings shall be DN 20 ( $\frac{3}{4}$  NPS) or larger and shall be in accordance with ISO 6708. Sizes DN 32, DN 65, DN 90, DN 125, DN 175 and DN 225 (1- $\frac{1}{4}$ , 2- $\frac{1}{2}$ , 3- $\frac{1}{2}$ , 5, 7, and 9 NPS) shall not be used.

**5.3.2** All connections shall be flanged or machined and studded, except where threaded connections are permitted by 5.3.6. All connections shall be suitable for the maximum allowable working pressure of the casing. Main inlet and outlet process connections shall be oriented as specified. Flanged connections may be integral with the casing or, for casings of weldable material, may be formed by a socket-welded or butt-welded pipe nipple or transition piece, and shall terminate with a welding-neck or socket-weld flange.

**5.3.3** Connections welded to the casing shall meet the material requirements of the casing, including impact values, rather than the requirements of the connected piping (see 5.11.4.5). All welding of connections shall be completed before the casing is hydrostatically tested. (see 7.3.2).

**5.3.4** A casing drain shall be provided.

**5.3.5** Butt welded connections, size DN 40 (1- $\frac{1}{2}$  NPS) and smaller, shall be reinforced by using forged welding inserts or gussets.

**5.3.6** For connections other than main process connections, if flanged or machined and studded openings are impractical, threaded connections for pipe sizes not exceeding DN 40 (1-½ NPS) may be used with purchaser's approval as follows:

- a) On non-weldable materials, such as cast iron;
- b) Where essential for maintenance (disassembly and assembly);
- c) When space is limited.

**5.3.7** Pipe nipples screwed or welded to the casing should not be more than 150 mm (6 in) long and shall be a minimum of Schedule 160 seamless for sizes DN 25 (1 NPS) and smaller and a minimum of Schedule 80 for DN 40 (1-½ NPS).

**5.3.8** The pipe nipple shall be provided with a welding-neck or socket-weld flange.

**5.3.9** The nipple and flange material shall meet the requirements of 5.3.3.

**5.3.10** Threaded openings and bosses for pipe threads shall conform to ISO 7—Parts 1 and 2 (ANSI/ASME B16.5).

**5.3.11** Threaded openings not required to be connected to piping shall be plugged with solid, steel plugs in accordance with ANSI/ASME B 16.11. As a minimum, these plugs shall meet the material requirements of the pressure casing. Plugs that may later require removal shall be of a corrosion-resistant material. Plastic plugs are not permitted. A process compatible thread lubricant of proper temperature specification shall be used on all threaded connections. Thread tape or thread sealant shall not be used.

**5.3.12** Flanges shall conform to ISO 7005-1 or 7005-2, or ANSI/ASME B16.1, B16.5, or B16.42 or B16.47 Series A or B, as applicable, except as specified in 5.3.12.1 through 5.3.12.4.

**5.3.12.1** Cast iron flanges shall be flat faced and conform to the dimensional requirements of ISO 7005-2 or ANSI/ASME B16.1 or B16.42. Class 125 flanges shall have a minimum thickness equal to Class 250 for sizes DN 200 (8 NPS) and smaller.

Note: For general purpose equipment, relaxation of the Class 250 thickness requirement may be considered. Bolting dimensions are equivalent for Class 125 and 250 flanges. The added thickness is preferred for most machinery applications.

**5.3.12.2** Flanges other than cast iron shall conform to the dimensional requirements of ISO 7005-1 or ANSI/ASME B16.5 or B16.47.

**5.3.12.3** Flat face flanges with full raised face thickness are acceptable on casings of all materials. Flanges in all materials that are thicker or have a larger outside diameter than required by ISO (ANSI) are acceptable. Non-standard (oversized) flanges shall be completely dimensioned on the arrangement drawing.

**5.3.12.4** Flanges shall be full faced or spot faced on the back and shall be designed for through bolting.

**5.3.13** Machined and studded connections shall conform to the facing and drilling requirements of ISO 7005-1 or 7005-2 ANSI/ASME B16.1, B16.5, B16.42, or B16.47 Series A or B. Studs and nuts shall be furnished installed, the first 1.5 threads at both ends of each stud shall be removed.

**5.3.14** Machined and studded connections and flanges not in accordance with ISO 7005-1 or 7005-2 or ANSI/ASME B16.1, B16.5, B16.42 or B16.47 require purchaser's approval. Unless otherwise specified, the vendor shall supply mating flanges, studs and nuts for these nonstandard connections.

**5.3.15** To minimize nozzle loading, and facilitate installation of piping, machine flanges shall be parallel to the plane shown on the general arrangement drawing to within 0.5°. Studs or bolt holes shall straddle centerlines parallel to the main axes of the equipment.

**5.3.16** All of the purchaser's connections shall be accessible for disassembly without requiring the machine, or any major part of the machine, to be moved.

## 5.4 External forces and moments

**5.4.1** As a minimum the compressor shall be designed to withstand external forces and moments on each nozzle as tabulated in Annex C. The vendor shall furnish the allowable forces and moments for each nozzle in tabular form.

Note: Silencers may require additional support.

**5.4.2** Casing and supports shall be designed to have sufficient strength and rigidity to limit distortion of coupling alignment due to pressure, torque, and allowable forces and moments to 50  $\mu\text{m}$  (0.002 in).

Note: The use of expansion joints to limit piping forces and moments is not generally recommended. However, if used, care should be exercised in the selection and location of expansion joints to prevent possible early fatigue due to either pulsation or expansion strain or both. Expansion joints should not be used in flammable or toxic service unless specifically approved by the purchaser.

## 5.5 Rotating elements

### 5.5.1 Rotors

**5.5.1.1** Rotor stiffness shall be adequate to prevent contact between the rotor bodies and the casing and between gear-timed rotor bodies at the most unfavorable specified conditions. Rotor bodies not integral with the shaft shall be permanently attached to the shaft to prevent relative motion under any condition. Structural welds on rotors shall be full-penetration continuous welds and shall be stress relieved, with appropriate ASTM heat treatment procedure.

Note: Only dry screw compressors are furnished with gear-timed rotor bodies.

**5.5.1.2** Shafts shall be forged steel unless otherwise approved by the purchaser.

- **5.5.1.3** If specified or when vibration and/or axial-position probes are furnished, the rotor shaft sensing areas to be observed by radial-vibration probes shall be concentric with the bearing journals. All shaft sensing areas (both radial vibration and axial position) shall be free from stencil and scribe marks or another surface discontinuity, such as an oil hole or a keyway, for a minimum of one probe-tip diameter on each side of the probe. These shall not be metallized, sleeved, or plated. The final surface finish shall be a maximum of 0.8  $\mu\text{m}$  (32  $\mu\text{in}$ ) Ra, preferably obtained by honing or burnishing.

These areas shall be properly demagnetized to the levels specified in API Standard 670 or otherwise treated so that the combined total electrical and mechanical runout does not exceed 25 percent of the maximum allowed peak-to-peak vibration amplitude or the following value, whichever is greater:

- a) For areas to be observed by radial-vibration probes, 6  $\mu\text{m}$  (0.25 mil).
- b) For areas to be observed by axial-position probes, 13  $\mu\text{m}$  (0.5 mil).

**5.5.1.4** Each rotor set shall be clearly marked with a unique identification number on each male and female rotor. This number shall be on the end of the shaft opposite the coupling or in an accessible area that is not prone to maintenance damage.

**5.5.1.5** Shaft ends shall conform to the requirements of ISO 10441 (API Standard 671).

**5.5.1.6** All shaft keyways shall have fillet radii conforming to ANSI/ASME B17.1.

### 5.5.2 Timing gears (dry screw compressors)

**5.5.2.1** Timing gears shall be made of forged steel and shall be a minimum of ISO/AGMA 1328 Quality 5. Timing gears shall be of the helical type. ISO/AGMA service factor shall be a minimum of 3.0.

**5.5.2.2** The meshing relationship between gear-timed rotors shall be adjustable and the adjustment shall be arranged for positive locking. The adjustment and locking provisions shall be accessible with the rotors in their bearings. The gear enclosing chamber shall not be subject to contact with the gas.

**5.5.2.3** Where timing gears have to be removed for seal replacement, it shall be possible to retime the rotors without further disassembly of radially split casings.

**5.5.2.4** Timing gears for helical lobe compressors shall have the same helix hand (right or left) as the rotors so that axial position has minimal effect on timing.

**5.5.2.5** Inspection ports or other means, shall be provided on the housing covers, such that timing gears may be inspected without disassembly of the unit.

## 5.6 Shaft seals

### 5.6.1 General

**5.6.1.1** Shaft seals shall be provided to restrict or prevent process gas leakage to the atmosphere.

**5.6.1.2** Seal operation shall be suitable for specified variations in suction or discharge conditions that may prevail during start-up, shutdown, or settling out, and during any other special operation specified by the purchaser.

Note: Whether the seals are exposed to suction or discharge conditions depends on seal location and on seal system configuration.

- **5.6.1.3** The purchaser may specify a sealing pressure provided it meets the requirements of 5.6.1.2 as a minimum.

**5.6.1.4** The shaft seals and seal support system shall be designed to permit safe compressor pressurization with the seal system in operation prior to process start-up.

**5.6.1.5** For low-temperature services systems shall have provision for maintaining the seal fluid above its pour-point temperature at the inner-seal drain.

**5.6.1.6** Shaft seals should be accessible for inspection and replacement without removing the top half of the casing of an axially split compressor or the end housings of a radially split unit.

Note: It is recognized that casing disassembly may be required for access to seals on some designs.

- **5.6.1.7** Shaft seals may be one of—or a combination of—the types described in 5.6.3 through 5.6.4 as specified by the purchaser or other types as mutually agreed. Materials of component parts shall be suitable for the service.

**5.6.1.8** When either the process or seal support fluid are toxic or flammable, a separation seal is required in addition to the primary seal to prevent leakage to the atmosphere or to the bearing housing. This separation seal shall be capable of acting as a temporary emergency backup seal should the primary seal fail during operation. The second seal in a tandem seal or a separate single or double seal may be used as the separation seal. See Figures 2 and 3 for typical arrangement of separation seals.

**5.6.1.9** Dry screw compressors with self acting dry gas seals, and unless otherwise agreed by the purchaser, other shaft seal types, shall have provisions for buffer gas injection to each seal.

### 5.6.2 Seal support systems

- **5.6.2.1** The purchaser should specify whether any of the following seal support systems are required:
  - a) seal barrier gas
  - b) seal buffer gas
  - c) separation seal gas

In addition, the vendor shall state whether seal fluid is required for any specified operating conditions.

**5.6.2.2** If buffer gas injection is provided, the vendor shall state the gas requirements including pressures, flowrates, dew points and filtration.

- **5.6.2.3** If specified, the vendor shall furnish the complete seal support system, including schematic and bill of material. The method of control, design, materials, and scope of supply will be mutually agreed by the purchaser and the vendor.

**5.6.2.4** If a barrier or buffer gas is required, the gas shall be filtered and shall be dry and free of any contaminants that form residues. The seal gas source may be taken from the compressor discharge or intermediate point. An alternate seal gas source may be used, and may be required during start-up or shutdown and for separation seal.

**5.6.2.5** Support systems for self-acting dry gas seals shall be in accordance with API 614 Chapters 1 and 4.

**5.6.3 Shaft seals for dry screw compressors**

**5.6.3.1 Labyrinth type**

The labyrinth seal (a typical seal is shown in Figure 4) may include restrictive-ring type in addition to the labyrinths if approved by the purchaser. Labyrinths may be stationary or rotating.

**5.6.3.2 Restrictive-ring-type**

Restrictive-ring-type seals (a typical seal is shown in Figure 5) shall include rings of carbon or other suitable material mounted in retainers or spacers. The seals may be operated dry, or with a sealing liquid.

**5.6.3.3 Mechanical (contact) type**

**5.6.3.3.1** Single mechanical (contact)-type seals (a typical seal is shown in Figure 6) shall be provided with labyrinths and slingers or restrictive rings to minimize oil leakage to the atmosphere or into the compressor. Oil or other suitable liquid furnished under pressure to the rotating faces may be supplied from the lube oil system or from an independent system in accordance with 5.10.

**5.6.3.3.2** Mechanical-type seals shall incorporate a self-closing feature to prevent uncontrolled gas leakage from the compressor on shutdown and loss of seal oil pressure.

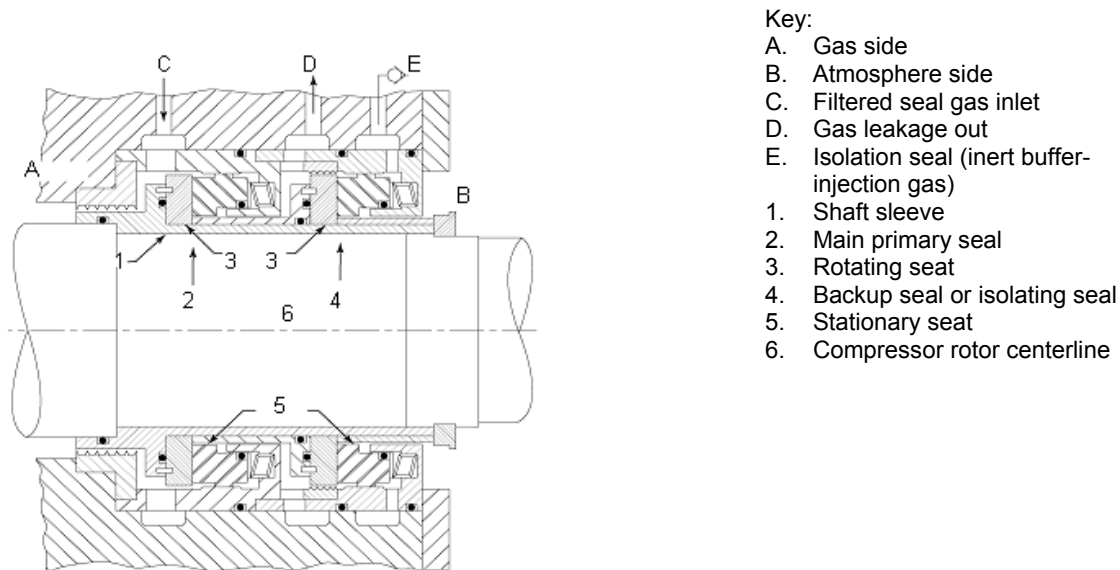

- Key:
- A. Gas side
  - B. Atmosphere side
  - C. Filtered seal gas inlet
  - D. Gas leakage out
  - E. Isolation seal (inert buffer-injection gas)
  - 1. Shaft sleeve
  - 2. Main primary seal
  - 3. Rotating seat
  - 4. Backup seal or isolating seal
  - 5. Stationary seat
  - 6. Compressor rotor centerline

**Figure 2—Self-Acting Gas Seal—Tandem Arrangement**

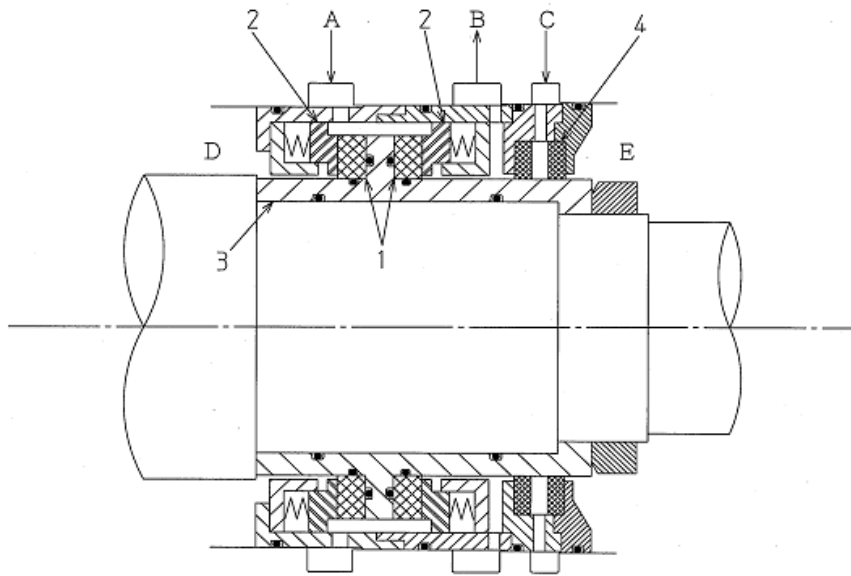

- 1. Rotating seat
- 2. Stationary seat
- 3. Rotor sleeve
- 4. Barrier / isolation seal
- A. Filtered seal gas inlet
- B. Gas leakage out
- C. Barrier / isolation seal clean, dry gas supply
- D. Gas side
- E. Atmosphere side

**Figure 3—Self-Acting Gas Seal—Double Arrangement**

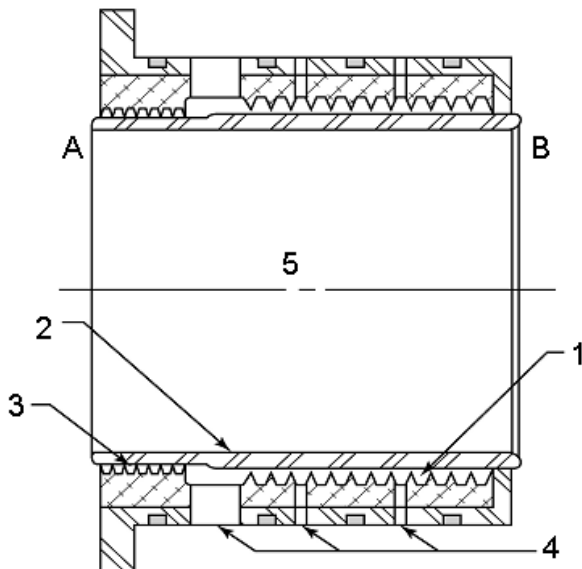

- Key:
- A. Atmosphere side
  - B. Gas side
  - 1. Labyrinth
  - 2. Shaft sleeve
  - 3. Wind back oil seal
  - 4. Ports for venting, purging or scavenging as required
  - 5. Compressor rotor centerline

**Figure 4—Labyrinth Shaft Seal**

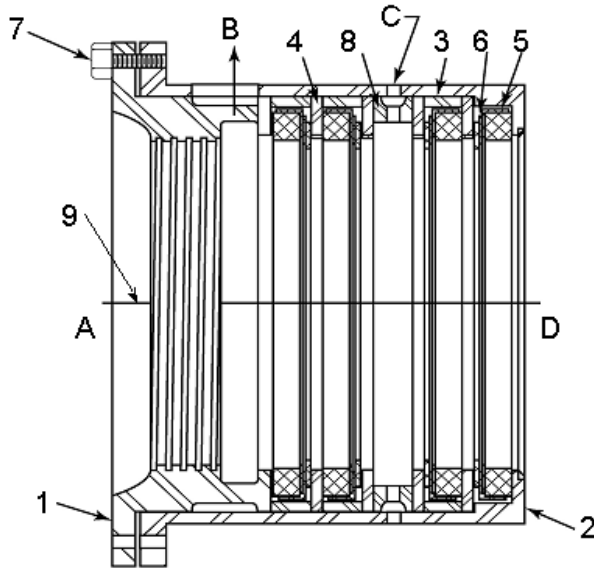

- Key:
- A. Atmosphere side
  - B. Vent to atmosphere
  - C. Purge
  - D. Gas side
  - 1. Windback labyrinth
  - 2. Seal cage
  - 3. Spacer ring
  - 4. Spacer washer
  - 5. Seal assembly
  - 6. Washer spring
  - 7. Capscrew
  - 8. Spacer ring
  - 9. Compressor rotor centerline

Figure 5—Restrictive-Ring Type Seal (Purged)

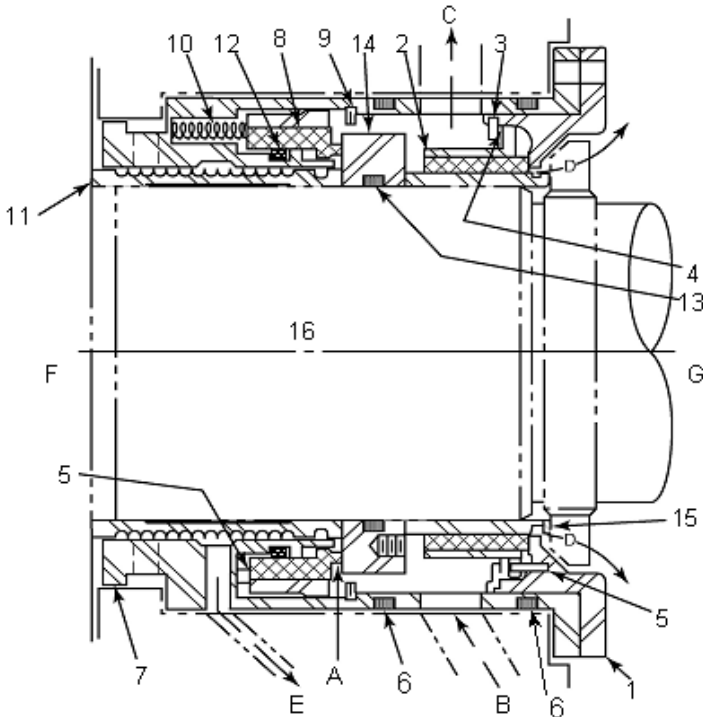

- Key:
- A. Seal face
  - B. Seal oil inlet
  - C. Seal oil return
  - D. Seal oil return
  - E. Leakage oil drain
  - F. Gas side
  - G. Atmosphere side
  - 1. Bushing retainer
  - 2. Bushing seal ring
  - 3. Snap ring
  - 4. Wave washer spring
  - 5. Rotation lock pin
  - 6. O-ring
  - 7. Seal housing
  - 8. Stationary seal ring
  - 9. Snap ring
  - 10. Compressive spring
  - 11. Sleeve
  - 12. O-ring
  - 13. O-ring
  - 14. Rotating face
  - 15. Runner
  - 16. Compressor rotor centerline

Figure 6—Oil Cooled Mechanical (Contact) Seal Assembly

### 5.6.3.4 Self-acting dry gas seal

- **5.6.3.4.1** Seal arrangement shall be single, double, or tandem as specified.

**5.6.3.4.2** A typical tandem arrangement is shown in Figure 2, and double arrangement with separation seal in Figure 3.

Note 1: Other variations are commonly used depending on the particular application.

Note 2: There is the possibility of the seal being unidirectional in rotation.

Note 3: The seal will leak a small amount of seal gas.

### 5.6.4 Shaft seals for oil-flooded screw compressors

**5.6.4.1** Mechanical (contact)-type seals (a typical seal is shown in Figure 6) shall be provided with labyrinths, slingers or restrictive rings to minimize oil leakage to the atmosphere. Oil furnished under pressure to the rotating faces may be supplied from the lube oil system in accordance with 5.10.

- **5.6.4.2** If specified that gas leakage to atmosphere is not permissible, oil-flooded screws require dual seal designs with independent seal fluid system.

Note: For refrigeration services, consideration must also be given for introduction of inert gases into the system.

**5.6.4.3** The arrangement of self-acting dry gas seals shall be single, tandem or double as specified. See 5.6.3.4

## 5.7 Dynamics

### 5.7.1 General

**5.7.1.1** In the design of rotor-bearing systems, consideration shall be given to all potential sources of periodic forcing phenomena (excitation) which shall include, but are not limited to, the following sources:

- Unbalance in the rotor system.
- Oil-film instabilities (whirl).
- Internal rubs.
- Pocket passing frequencies.
- Gear-tooth meshing and side bands.
- Coupling misalignment.
- Loose rotor-system components.
- Hysteretic and friction whirl.
- Asynchronous whirl.
- Ball and race frequencies of rolling element bearings.
- Electrical line frequency.

Note 1: The frequency of a potential source of excitation may be less than, equal to, or greater than the rotational speed of the rotor.

Note 2: When the frequency of a periodic forcing phenomenon (excitation) applied to a rotor-bearing-support system coincides with a natural frequency of that system, the system will be in a state of resonance. A rotor-bearing-support system in resonance may have the magnitude of its normal vibration amplified. The magnitude of amplification and, in the case of critical speeds, the rate of change of the phase-angle with respect to speed, are related to the amount of damping in the system.

**5.7.1.2** When the rotor amplification factor (see Figure 7) as measured at the shaft radial vibration probes, is greater than or equal to 2.5, the corresponding frequency is called a critical speed, and the corresponding shaft rotational frequency is also called a critical speed. For the purposes of this standard, a critically damped system is one in which the amplification factor is less than 2.5.



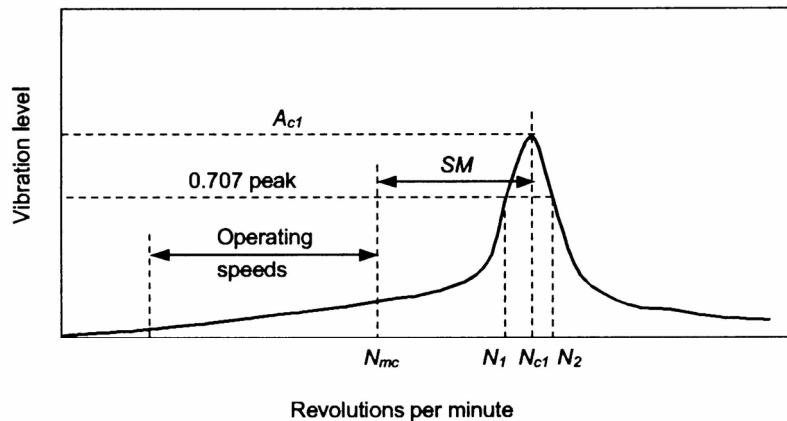

- $N_{c1}$  = Rotor first critical, center frequency, cycles per minute  
 $N_{mc}$  = Maximum continuous speed, 105 percent  
 $N_1$  = Initial (lesser) speed at 0.707 x peak amplitude (critical)  
 $N_2$  = Final (greater) speed at 0.707 x peak amplitude (critical)  
 $N_2 - N_1$  = Peak width at the half-power point  
 $AF$  = Amplification factor  
     =  $N_{c1} / (N_2 - N_1)$   
 $SM$  = Separation margin  
 $A_{c1}$  = Amplitude at  $N_{c1}$

**Figure 7—Rotor Response Plot**

**5.7.1.3** Resonances of structural support systems that are within the vendor's scope of supply and that affect the rotor vibration amplitude shall not occur within the specified operating speed range or the specified separation margin (see 5.7.1.4). The effective stiffness of the vendor's structural support shall be considered in the analysis of the dynamics of the rotor-bearing-support system.

Note: Resonances of structural support systems may adversely affect the rotor vibration amplitude.

**5.7.1.4** Rotors shall be of a stiff-shaft construction with the first actual lateral critical speed at least 120% of the maximum allowable speed. Unless otherwise specified a lateral critical analysis is not required.

Note: In most cases based on historical data the vendor will be able to demonstrate that the machine has a stiff shaft design.

## 5.7.2 Torsional analysis

- 5.7.2.1** For motor-driven units and units including gears, units comprising three or more coupled machines (excluding any gears), or when specified, the vendor having unit responsibility shall ensure that a torsional vibration analysis of the complete coupled train is carried out and shall be responsible for directing any modifications necessary to meet the requirements of 5.7.2.2 through 5.7.2.5.

**5.7.2.2** Excitation of torsional natural frequencies may come from many sources which may or may not be a function of running speed and should be considered in the analysis. These sources shall include but are not limited to the following:

- Gear characteristics such as unbalance, pitch line runout, and cumulative pitch error.
- Cyclic process impulses.
- Torsional transients such as start-up of synchronous electric motors and generator phase-to-phase or phase-to-ground faults.
- Torsional excitation resulting from electric motors, reciprocating engines, and rotary-type positive-displacement machines.

- e) Control loop resonances from hydraulic, electronic governors, and variable frequency drives.
- f) One- and two-times line frequency.
- g) Running speed or speeds of all rotating elements.
- h) Pocket passing frequency.
- i) Harmonic frequencies from variable frequency drives.

**5.7.2.3** The torsional natural frequencies of the complete train shall be at least 10% above or 10% below any possible excitation frequency within the specified operating speed range (from minimum to maximum continuous speed).

**5.7.2.4** Torsional criticals at two or more times running speeds should be avoided or, in systems in which corresponding excitation frequencies occur, shall be shown to have no adverse affect. In addition to multiples of running speeds, torsional excitations that are not a function of operating speeds or that are nonsynchronous in nature shall be considered in the torsional analysis when applicable and shall be shown to have no adverse effect. Identification of these frequencies shall be the mutual responsibility of the purchaser and the vendor.

Note: If variable speed driver is used, it may not be possible to avoid torsional criticals at multiples of all speeds in the operating range.

**5.7.2.5** When torsional resonances are calculated to fall within the margin specified in 5.7.2.2 (and the purchaser and the vendor have agreed that all efforts to remove the critical from within the limiting frequency range have been exhausted), a stress analysis shall be performed to demonstrate that the resonances have no adverse effect on the complete train. The assumptions made in this analysis regarding the magnitude of excitation and the degree of damping shall be clearly stated. The acceptance criteria for this analysis shall be mutually agreed upon by the purchaser and the vendor.

**5.7.2.6** In addition to the torsional analysis required in 5.7.2.2 through 5.7.2.5, the vendor shall perform a transient torsional vibration analysis for synchronous driven units and/or variable speed motors. The acceptance criteria for this analysis shall be mutually agreed upon by the purchaser and the vendor.

### 5.7.3 Vibration and balance

**5.7.3.1** Major parts of the rotating element, such as the shaft and timing gears shall be individually dynamically balanced, to ISO 1940 Grade G 2.5 or better. When a bare shaft with a single keyway is dynamically balanced, the keyway shall be filled with a fully crowned half key, in accordance with ISO 8821. Keyways 180° apart, but not in the same transverse plane, shall also be filled. The initial balance correction to the bare shaft shall be recorded. The components to be mounted on the shaft shall also be balanced in accordance with the “half-key convention” as described in ISO 8821.

**5.7.3.2** The rotors and timing gears shall be matchmarked or keyed. This assembly shall be check-balanced (including keys). Exposed keys and unfilled keyways are unacceptable. The maximum unbalance shall be per grade G 2.5 of ISO 1940/ANSI S2.19.

- **5.7.3.3** If specified, balance grade ISO 1940 Grade G 1.0 or 4W/N shall be provided.

Note: For this equipment, the gas forces and variations in gas forces are orders of magnitude higher than the forces resulting from unbalance.

**5.7.3.4** The calibration of the rotor balancing machine shall be verified in accordance with the balancing machine manufacturer’s procedure and frequency, or once a year as a minimum.

- **5.7.3.5** If specified, a residual unbalance check shall be performed in accordance with Annex D.

**5.7.3.6** During the shop test of the machine, assembled with the balanced rotor operating at maximum continuous speed or at any other speed within the specified operating speed range, the casing vibration velocity shall be measured, or if specified for dry screw compressors the shaft vibrations shall be measured in accordance with API Standard 670. Unless otherwise specified, the limits in Table 3 shall apply to dry screw compressors and limits in Table 4 shall apply to oil-flooded screw compressors.

**5.7.3.7** When shaft vibration probes are supplied, electrical and mechanical runout shall be determined and recorded by rolling the rotor in V-blocks at the journal centerline while measuring runout with a noncontacting vibration probe and a dial indicator at the centerline of the probe location and one probe-tip diameter to either side.

**5.7.3.8** Accurate records of electrical and mechanical runout, for the full 360 degrees at each probe location, shall be included in the mechanical test report.

**5.7.3.9** If the vendor can demonstrate that electrical or mechanical runout is present, a maximum of 25% of the test level calculated from Table 3 or 6.5  $\mu\text{m}$  (0.25 mil), whichever is greater, may be vectorially subtracted from the vibration signal measured during the factory test.

## 5.8 Bearings

### 5.8.1 General

**5.8.1.1** Bearings shall be one of the following arrangements: rolling element radial and thrust, hydrodynamic radial and rolling element thrust or hydrodynamic radial and thrust. Each shaft shall be supported by two radial bearings and one double acting axial (thrust) bearing which may or may not be combined with one of the radial bearings. Unless otherwise specified, the bearing type and arrangement shall be selected in accordance with the limitations in Table 5 and Table 6.

**Table 3—Vibration Limits for Dry screw compressors**

Measurement on Bearing housing	Hydrodynamic Bearings	Rolling Element Bearings
Vibration at any speed within operating range		
Overall	$V_u < 5.0 \text{ mm/s RMS}$ (0.2 in/s RMS)	$V_u < 8.0 \text{ mm/s RMS}$ (0.3 in/s RMS)
Increase in allowable vibrations at speeds beyond operating speed but less than trip speed	50%	50%
<b>Measurement on shaft adjacent to bearing</b>		
Overall vibration at any speed within the operating speed range	"A" shall be the lesser value of $\sqrt{(1.03 \cdot 10^7 / \text{rpm})}$ in $\mu\text{m}$ $\sqrt{(16000 / \text{rpm})}$ in mils or 50% bearing clearance	
Increase in allowable vibration at speeds beyond operating speed but less than trip speed	50%	
Where : $V_u$ = unfiltered velocity A = unfiltered peak to peak amplitude of vibration rpm = max continuous speed in revolution per minute RMS = root mean square		

**Table 4—Vibration Limits for Oil-Flooded Screw Compressors**

Measurement on Bearing housing	Hydrodynamic Bearings	Rolling Element Bearings
Vibration at any speed within operating range		
Overall	$V_u < 8.0 \text{ mm/s RMS}$ (0.3 in/s RMS)	$V_u < 8.0 \text{ mm/s RMS}$ (0.3 in/s RMS)
Increase in allowable vibrations at speeds beyond operating speed but less than trip speed	50%	50%
Where : $V_u$ = unfiltered velocity RMS = root mean square		
Note: The pulsating oil flow through the oil-flooded screw compressor causes increased vibration. Oil-flooded screw compressors with hydrodynamic bearings typically operate with higher compression ratios and/or higher discharge pressures than machines with rolling elements bearings.		

**5.8.1.2** Thrust bearings shall be sized for continuous operation through the full operating range including the most adverse specified operating conditions. Calculation of the thrust load shall include but shall not be limited to the following factors:

- a) Step thrust from all diameter changes.
- b) Stage reaction and stage differential pressure.
- c) Variations in pressure at all inlet and outlet nozzles.
- d) External loads from the driver or driven equipment, as described in 5.8.1.3 and 5.8.1.4.
- e) Highest transient load.

**5.8.1.3** Thrust forces from metallic flexible element couplings shall be calculated on the basis of the maximum allowable deflection permitted by the coupling manufacturer.

**5.8.1.4** If two or more rotor thrust forces are to be carried by one thrust bearing (such as in a gear box), the resultant of the forces shall be used provided the directions of the forces make them numerically additive.

If the forces are by design in opposite directions, they may be subtracted from each other (e.g. gear forces vs. clearly defined gas forces).

- **5.8.1.5** When specified, for dry screw compressors hydrodynamic thrust and radial bearings shall be fitted with bearing-metal temperature sensors installed in accordance with API Standard 670.

Note: For flooded screw compressors bearing temperature measurement is often not practical.

**Table 5—Bearing Selection**

Condition	Bearing Type & Arrangement
Radial and thrust bearing speed and life within limits for rolling element bearings & Machine energy density below limit	Rolling element radial and thrust
Radial bearing speed or life outside limits for rolling element bearings & Thrust bearing speed and life within limits for rolling element bearings & Machine energy density below limit	Hydrodynamic radial and rolling element thrust or Hydrodynamic radial and thrust
Radial and thrust bearing speed or life outside limits for rolling element bearings or Machine energy density above limit	Hydrodynamic radial and thrust

**Table 6—Bearing Limits**

**Rolling element bearing speed:**

Factor,  **$Nd_m$**  not to exceed the following values for pressurized oil lubricated bearings:

Bearing Type	<b><math>Nd_m</math></b>
Radial: single row ball bearings cylindrical roller bearings	500,000
Radial: tapered roller bearings spherical roller bearings	350,000
Thrust: single row ball bearings	350,000
Thrust: double row angular contact tapered roller bearings	300,000 250,000

where

- $D$  = bearing outer diameter, mm
- $d$  = bearing inner diameter, mm
- $d_m$  = mean bearing diameter  $(d + D)/2$ , mm
- $N$  = rotative speed, RPM

Note: For flooded screw compressors with special directed (jet) lubrication arrangement the acceptable  $Nd_m$  factor for radial and thrust ball bearings may be increased according to bearing manufacturer's recommendation.

#### Rolling element bearing life:

Basic rating  $L_{10}$  per ISO 281 (ANSI/ABMA Standard 9) of at least 50,000 hours with continuous operation at rated conditions, and at least 32,000 hours at maximum radial and axial loads and rated speed.

Note: The calculated bearing life is based on lubrication with clean, filtered oil. In oil-flooded screw compressors aggressive and/or contaminated process gases may significantly shorten the actual bearing life.

#### Energy density:

When the product of machine rated power, kW (HP), and rated speed, RPM, is 4.0 million (5.4 million) or greater, hydrodynamic radial and thrust bearings are required.

### 5.8.2 Rolling element bearings

**5.8.2.1** Rolling element bearings shall be located, retained and mounted in accordance with the following:

- a) Bearings shall be located on the shaft using shoulders, collars or other positive locating devices; snap rings and spring-type washers are not acceptable.
- b) Bearings shall be retained on the shaft with an interference fit and fitted into the housing with a diametrical clearance, both in accordance with the recommendations of ANSI/ABMA Standard 7.
- c) Bearings shall be mounted directly on the shaft; bearing carriers are not acceptable.

**5.8.2.2** Single row deep-groove ball bearings shall have greater than normal internal clearance according to ISO 5753 Group 3 (ANSI/ABMA Symbol 3, as defined in ABMA Standard 20).

**5.8.2.3** Rolling element bearings shall be selected in accordance with the following:

- a) A rolling element thrust bearing may be a single-row, deep-groove ball bearing provided the combined axial thrust and radial load is within the capability of such a bearing and requirements of 5.8.1 are satisfied.
- b) Where the loads exceed the capability of a single-row, deep-groove bearing, a matched pair of single-row, angular contact type bearings shall be used.
- c) Unless otherwise specified, bearings shall be mounted in a paired bi-directional arrangement. The need for bearing clearance or preload shall be determined by the vendor to suit the application and meet the bearing life requirements (Table 5).
- d) Rolling element thrust bearings shall be secured to the shaft with a nut and an appropriate locking method.
- e) Four-point contact (split race) ball bearings shall not be used for radial loads. Bearings with filling slots shall not be used.

### 5.8.3 Hydrodynamic bearings

**5.8.3.1** Hydrodynamic radial bearings shall be in accordance with 5.8.3.1.1 through 5.8.3.1.3.

**5.8.3.1.1** Hydrodynamic radial bearings shall be precision-bored, and of the sleeve or pad type, with steel-backed babbitted replaceable liners, pads, or shells. The bearings shall be equipped with antirotation pins and shall be positively secured in the axial direction.

**5.8.3.1.2** The bearing design shall suppress hydrodynamic instabilities and provide sufficient damping over the entire range of allowable bearing clearances to limit rotor vibration to the maximum specified amplitudes (see

Tables 3 and 4) while the unit is operating loaded or unloaded at specified operating speeds including operation at any resonant condition.

**5.8.3.1.3** Bearings shall be designed to prevent incorrect positioning.

**5.8.3.2** Hydrodynamic thrust bearings shall be in accordance with 5.8.3.2.1 through 5.8.3.2.4.

**5.8.3.2.1** The active sides of hydrodynamic thrust bearings shall be of the babbitted multiple-segment, self-leveling tilting-pad type or other types approved by the purchaser, sized for continuous operation under all specified operating conditions (including the maximum allowable differential pressure). The inactive-side thrust pads or segments shall be babbitted and arranged for positive lubrication.

**5.8.3.2.2** Unless otherwise specified, replaceable thrust collars shall be furnished and shall be positively locked to the shaft to prevent fretting.

**5.8.3.2.3** Thrust bearings shall be arranged to allow axial positioning of each rotor relative to the casing and setting of the bearings' clearance or preload.

**5.8.3.2.4** Hydrodynamic thrust bearings shall be selected at no more than 50% of the bearing manufacturer's ultimate load rating. The ultimate load rating is the load, that will produce the minimum acceptable oil-film thickness without inducing failure during continuous service or the load that will not exceed the creep-initiation or yield strength of the babbitt at the location of maximum temperature on the pad, whichever load is less. In sizing thrust bearings, consideration shall be given to the following for each specific application:

- a) The shaft speed.
- b) The temperature of the bearing babbit.
- c) The deflection of the bearing pad.
- d) The minimum oil film thickness.
- e) The feed rate, viscosity, and supply temperature of the oil.
- f) The design configuration of the bearing.
- g) The babbit alloy.
- h) The turbulence of the oil film.

The sizing of hydrodynamic thrust bearings shall be reviewed and approved by the purchaser.

## 5.9 Bearing housings

**5.9.1** Bearing housings for pressure-lubricated hydrodynamic bearings shall be arranged to minimize foaming. The drain system shall be adequate to maintain the oil foam level below shaft end seals. Oil outlets from thrust bearings shall be tangential and in the upper half of the control ring, or, if control rings are not used, in the thrust bearing cartridge.

**5.9.2** Oil connections on bearing housings shall be in accordance with 5.3.

**5.9.3** The rise in oil temperature through the bearing and housings shall not exceed 30K (50°F) under the most adverse specified operating conditions. The bearing outlet oil temperature shall not exceed 80°C (180°F). When the inlet oil temperature exceeds 50°C (120°F), special consideration shall be given to bearing design, oil flow, and allowable temperature rise. In this case outlet oil temperature may exceed 80°C (180°F).

Note: Oil-flooded screw compressors may require a relatively high oil inlet temperature to prevent formation of condensate from the process gas. Failure to maintain an adequate oil temperature may result in emulsified or contaminated lubricating oil.

**5.9.4** Where water cooling is required, water jackets shall have only external connections between upper and lower housing jackets and shall have neither gasketed nor threaded connection joints which may allow water to leak into the oil reservoir. If cooling coils (including fittings) are used, they shall be of nonferrous, metallic material and shall have no internal pressure joints. Tubing or pipe shall have a minimum wall thickness of 1.0 mm (0.040 in) and shall be at least 12 mm (0.50 in) outside diameter.

**5.9.5** Compressors shall have bearing-housing shaft seals and deflectors where the shaft passes through the housing; lip type seals shall not be used. The seals and deflectors shall be made of non-sparking materials. The design of the seals shall effectively retain oil in the housing and prevent entry of foreign material into the housing.

- **5.9.6** If specified, for dry screw compressors provision shall be made for mounting two radial vibration probes on each bearing, one axial position probe on each rotor and a one-event per revolution probe. The probe installation shall be as specified in API Standard 670.

Note: Some smaller machines may not accommodate proximity type probes due to space limitations.

- **5.9.7** When specified, bearing housings shall be prepared for permanently mounting seismic vibration transducers in accordance with API Standard 670. When metric fasteners are supplied, the threads shall be M8.
- **5.9.8** When specified, a flat surface of an agreed size and location shall be provided for mounting of magnetic-based seismic vibration measuring equipment.

## **5.10 Lube-oil and seal-oil systems**

### **5.10.1 General**

**5.10.1.1** Unless otherwise specified, a pressurized oil system shall be furnished to supply oil at a suitable pressure or pressures, as applicable, to the following:

- a) The bearings of the driver and of the driven equipment (including any gear).
  - b) Any governor and control-oil system.
  - c) The seal-oil system, if combined with the lube-oil system.
  - d) Rotor internal cooling.
  - e) Rotors of oil-flooded compressors including slide valve.
- **5.10.1.2** Relief valves whose sole purpose is to protect blocked-in equipment (for example, coolers or filters) from thermal expansion shall be supplied if specified by the purchaser. The purchaser shall mark THERM outside the relief valve symbol on the schematic when the relief valve is for protection from thermal expansion only.

### **5.10.2 Dry screw compressors**

**5.10.2.1** Where oil is supplied from a common system to two or more components of a machinery train (such as a compressor, a gear, and a motor), the vendor having unit responsibility shall ensure compatibility of type, grade, pressure and temperature of oil for all equipment served by the common system.

Note: The usual lubricant employed in a common oil system is a mineral oil that corresponds to ISO 3448 Grade 32 or Grade 46. Compatibility of lube oil requirements needs to be mutually agreed among the user and all vendors supplying equipment served by the common system. In some cases there can be significant differences in individual component needs.

**5.10.2.2** Unless otherwise specified, bearings and bearing housings shall be arranged for oil lubrication using a mineral oil in accordance with ISO 3448.

**5.10.2.3** Unless otherwise specified, pressurized oil systems for dry screw compressors shall conform to the requirements of API Standard 614 Chapters 1 and 2.

- **5.10.2.4** If specified, an oil reservoir integral to the base frame shall be provided in accordance with the requirements of API 614 Chapter 3.
- **5.10.2.5** If specified, a full capacity shaft-driven oil pump shall be provided in accordance with the requirements of API 614.

Note: This pump is typically driven by the low speed shaft of the gear box.

### 5.10.3 Flooded screw compressors

#### 5.10.3.1 General

**5.10.3.1.1** Flooded screw compressors shall utilize a pressurized reservoir and separation vessels. Typical systems are described in Annex E.

Note: Oil systems for flooded screw compressors are designed with consideration of the following features:

- a) Lube oil is in contact with process gas.
- b) Lube oil system forms a part of process gas system.
- c) Lube oil system is segregated from the atmosphere.
- d) Lube oil is pressurized to the discharge gas pressure. In some cases the lube oil can flow into the compressor bearing and seal sections without pumping-up (driven by differential pressure).

**5.10.3.1.2** The oil system shall utilize a lubricant compatible with the process gas.

Note: Compatibility issues may include, but not be limited to the following:

- a) dilution
- b) degassing
- c) corrosion
- d) viscosity changes
- e) moisture absorption
- f) oil affecting the process
- g) shaft seal type

**5.10.3.1.3** The purchaser may specify optional lube oil components to be supplied.

Note: Refer to Annex E for examples of typical lube oil systems and their arrangements.

**5.10.3.1.4** The discharge temperature in any specified operating condition shall be maintained at least 10K (18°F) higher than the dew point of the process gas components and water vapor.

**5.10.3.1.5** The gas pipe between the compressor discharge nozzle and the first oil separator shall be sized to withstand pulsation, high volume mixed phase flow and vibration loads.

**5.10.3.1.6** Lube and seal oil system components listed below shall conform to the requirements of API 614 Chapters 1 and 2.

- a) transfer valves
- b) gauges
- c) heaters

Note: For piping and tubing see 6.5.1 and 6.5.2.

#### 5.10.3.2 Oil filters

Oil filters shall conform to the requirements of API 614 Chapter 2 and to the following:

- a) Oil filters for bearing, seal, and control oil supply shall provide a minimum particle removal efficiency of 99.5% for 10 µm particles (beta > 200).
- b) Particle removal by oil filters for rotor supply (injection) oil shall be agreed by the supplier and the purchaser.

#### 5.10.3.3 Coolers

- **5.10.3.3.1** A single oil cooler shall be provided in accordance with API 614 Chapter 1 and 3. The cooler shall be liquid-cooled, shell-and-tube or plate type, or air-cooled type as specified. Internal oil coolers are not acceptable.

The vendor shall include in the proposal complete details of any proposed shell-and-tube type, plate type or air-cooled type cooler.

- **5.10.3.3.2** If specified, dual coolers shall be provided. Each cooler shall be sized for the full heat load.



**5.10.3.3.3** Unless otherwise specified, the cooler shall be sized to handle the full heat load of any specified operating condition and the unloaded condition.

#### 5.10.3.4 Pumps

**5.10.3.4.1** Unless otherwise specified, dual pumps shall be furnished in accordance with API 614 Chapter 3. At least one pump shall be motor driven.

- **5.10.3.4.2** If specified, or agreed, a single pump may be furnished.

Note: On some systems, the pump is required for start-up only.

**5.10.3.4.3** A strainer shall be provided upstream of the pump(s).

#### 5.10.3.5 Oil separators

**5.10.3.5.1** For flooded screw compressors, an oil separation vessel or vessels shall be supplied as specified in 5.10.3.5.2 through 5.10.3.5.5.

- **5.10.3.5.2** The allowable oil carryover at the certified point (in parts per million by mass) in the process gas stream that leaves the separator shall be specified.

Note 1: The oil carryover may increase at operating conditions other than certified point.

Note 2: Multiple separators may be required for services that have stringent limits on oil carryover.

- **5.10.3.5.3** Separators shall be designed in accordance with the specified pressure design code.

**5.10.3.5.4** Unless otherwise specified, separators shall be constructed of carbon steel with a 3 mm ( $1/8$  in) corrosion allowance.

Note: Austenitic stainless steel should be specified for corrosive services or applications where the vessel interior is frequently exposed to the atmosphere.

- **5.10.3.5.5** Separators shall be equipped with the following characteristics and appendages:

- a) The capacity to avoid frequent filling and to provide adequate allowance for system rundown. A minimum 2-minute retention time shall be provided. The vendor shall specify the proposed separator dimensions and retention time, as well as maximum, minimum, and normal operating levels, in the proposal. See Figure E.4 in Annex E.

Note: Oil retention time is required for sufficient degassing to maintain the required oil characteristics.

- b) Internal coalescing filtration and impingement baffles, as necessary to achieve the specified allowable oil carryover concentration.
- c) Unless otherwise specified, a flanged safety relief valve in accordance with 6.4.4.6.
- d) A flanged opening (6 in minimum) for servicing and cleaning of the separator internals.
- e) Separate flanged vent, filter drain (if applicable), oil return, oil fill, and drain connections.
- f) A flanged, armored level gauge.
- g) A baffle by the gas inlet opening to help direct gas upward and oil downward.
- h) Stilling tubes on oil fill and return connections to direct oil to a level below the minimum operating level.
- i) A vortex breaker upstream of the oil outlet connection.
- j) If specified, separate, flanged connections for level switch, pressure differential indicator, pressure indicator, oil conditioner inlet, oil conditioner outlet, and electric heater.
- k) If specified, separate austenitic stainless steel thermowell connections for a temperature gauge and/or switch(es).
- l) If specified, electric heater with temperature control.

## 5.11 Materials

### 5.11.1 General

**5.11.1.1** Except as required or prohibited by this standard or by the purchaser, materials of construction shall be selected by the manufacturer for the operating and site environmental conditions specified (see 5.11.1.7).

Note: See 6.5 for requirements for auxiliary piping materials. The material(s) selected by the manufacturer should be reviewed and agreed to by the purchaser.

**5.11.1.2** The materials of construction of all major components shall be clearly stated in the vendor's proposal. Materials shall be identified by reference to applicable international standards, including the material grade (see Annex F). When no such designation is available, the vendor's material specification, giving physical properties—chemical composition, and test requirements—shall be included in the proposal.

Note: Where international standards are not available, internationally recognized national or other standards may be used.

- **5.11.1.3** When specified, copper or copper alloys shall not be used for parts of machines or auxiliaries in contact with process fluids. Nickel-copper alloy (UNS N04400), bearing babbitt, and precipitation-hardened stainless steels are excluded from this requirement.

**5.11.1.4** The vendor shall specify the optional tests and inspection procedures that may be necessary to ensure that materials are satisfactory for the service (see 5.11.1.2). Such tests and inspections shall be listed in the proposal.

Note: The purchaser may specify additional optional tests and inspections, especially for materials used for critical components or in critical services.

**5.11.1.5** External parts that are subject to rotary or sliding motions (such as control linkage joints and adjusting mechanisms) shall be of corrosion-resistant materials suitable for the site environment.

**5.11.1.6** Minor parts such as nuts, springs, washers, gaskets, and keys shall have corrosion resistance at least equal to that of specified parts in the same environment.

- **5.11.1.7** The purchaser shall specify any corrosive agents (including trace quantities) present in the motive and process fluids and in the site environment, including constituents that may cause stress corrosion cracking.

Note: Typical agents of concern are hydrogen sulfide, amines, chlorides, cyanide, fluoride, naphthenic acid and polythionic acid.

**5.11.1.8** If austenitic stainless steel parts exposed to conditions that may promote intergranular corrosion are to be fabricated, hard faced, overlaid or repaired by welding, they shall be made of low-carbon or stabilized grades.

Note: Overlays or hard surfaces that contain more than 0.10% carbon can sensitize both low-carbon and stabilized grades of austenitic stainless steel unless a buffer layer that is not sensitive to intergranular corrosion is applied.

**5.11.1.9** Where mating parts such as studs and nuts of austenitic stainless steel or materials with similar galling tendencies are used, they shall be lubricated with an antiseizure compound of the proper temperature specification and compatible with the specified process fluid(s).

Note: With and without the use of antiseizure compounds, the required torque loading values to achieve the necessary preload will vary considerably.

**5.11.1.10** When the purchaser has specified the presence of hydrogen sulfide in any fluid, materials exposed to that fluid shall be selected in accordance with the requirements of NACE Standard MR 0175. Ferrous materials not covered by NACE MR 0175 shall be limited to a yield strength not exceeding 620 N/mm<sup>2</sup> (90,000 psi) and a hardness not exceeding Rockwell C 22 (240 HRB). Components that are fabricated by welding shall be postweld heat treated, if required, so that both the welds and the heat-affected zones meet the yield strength and hardness requirements.

Note: It is the responsibility of the purchaser to determine the amount of wet H<sub>2</sub>S that may be present, considering normal operation, start-up, shutdown, idle standby, upsets or unusual operating conditions such as catalyst regeneration.

In many applications, small amounts of wet H<sub>2</sub>S are sufficient to require materials resistant to sulfide stress corrosion cracking. When there are trace quantities of wet H<sub>2</sub>S known to be present or if there is any uncertainty about the amount of wet H<sub>2</sub>S that may be present, the purchaser should automatically note on the data sheets that materials resistant to sulfide stress corrosion cracking are required.

**5.11.1.11** The vendor shall select materials to avoid conditions that may result in electrolytic corrosion. Where such conditions cannot be avoided, the purchaser and the vendor shall agree on the material selection and any other precautions necessary.

Note: When dissimilar materials with significantly different electrical potentials are placed in contact in the presence of an electrolytic solution, galvanic couples that can result in serious corrosion of the less noble material may be created. The *NACE Corrosion Engineer's Reference Book* is one resource for selection of suitable materials in these situations.

**5.11.1.12** Where applicable, materials and casting factors shall be equal to those required by the specified pressure design code. The manufacturer's data report forms, as specified in the code, are not required.

Note: For impact requirements refer to 5.11.5.

**5.11.1.13** Low-carbon steels can be notch sensitive and susceptible to brittle fracture at ambient or low temperatures. Therefore, only fully killed, normalized steels made to fine-grain practice are acceptable. The use of steel made to a coarse austenitic grain size practice (such as ASTM AS 15) is prohibited.

**5.11.1.14** O-ring materials shall be compatible with all specified services. Special consideration shall be given to the selection of O-rings for high pressure services to ensure that they will not be damaged upon rapid depressurization (explosive decompression).

Note: Susceptibility to explosive decompression depends on the gas to which the O-ring is exposed, the compounding of the elastomer, temperature of exposure, the rate of decompression, and the number of cycles.

**5.11.1.15** The minimum quality bolting material for pressure joints shall be carbon steel (such as ASTM A 307, Grade B) for cast iron casings and high temperature alloy steel (such as ASTM A 193, Grade B7) for steel casings. Carbon steel nuts (such as ASTM A 194 2H) shall be used. Where space is limited, case hardened carbon steel nuts (such as ASTM A 563, Grade A) shall be used. For temperatures below -30°C (-20°F), low-temperature bolting material in accordance with ASTM A 320 shall be used.

## 5.11.2 Castings

**5.11.2.1** Castings shall be sound and free from porosity, hot tears, shrink holes, blow holes, cracks, scale, blisters, and similar injurious defects. Surfaces of castings shall be cleaned by sandblasting, shotblasting, chemical cleaning, or any other standard method. Mold-parting fins and remains of gates and risers shall be chipped, filed, or ground flush.

**5.11.2.2** The use of chaplets in pressure castings shall be held to a minimum. Where chaplets are necessary, they shall be clean and corrosion-free (plating is permitted) and of a composition compatible with the casting.

**5.11.2.3** All repairs that are not covered by ASTM or other internationally recognized material specifications shall be subject to the purchaser's approval.

**5.11.2.4** Fully-enclosed cored voids, which become fully enclosed by methods such as plugging, welding, or assembly, are prohibited.

**5.11.2.5** Pressure containing ferrous castings shall not be repaired, except as specified in 5.11.2.5.1 and 5.11.2.5.2.

**5.11.2.5.1** Weldable grades of steel castings shall be repaired by welding, using a qualified welding procedure based on the requirements of the specified pressure design code. After major weld repairs, and before hydrotest, the complete repaired casting shall be given a postweld heat treatment to ensure stress relief and continuity of mechanical properties of both weld and parent metal and dimensional stability during subsequent machining operations.

**5.11.2.5.2** Cast gray iron may be repaired by plugging within the limits specified in ASTM A 278. The holes drilled for plugs shall be carefully examined, using liquid penetrant, to ensure that all defective material has been removed.

**5.11.2.6** Ductile iron castings shall be produced in accordance with an internationally recognized standard such as ASTM A 395 or A 536. The production of the castings shall also conform to the conditions specified in 5.11.2.6.1 through 5.11.2.6.4.

Note: Ductile iron is also commonly referred to as nodular iron or spheroidal graphite (SG) iron.

**5.11.2.6.1** The keel or Y-block cast at the end of the pour shall be at least as thick as the thickest section of the main casting. This test block shall be tested for tensile strength and hardness and shall be microscopically examined. Classification of graphite nodules under microscopic examination shall be in accordance with ISO 945 or ASTM A 247.

Note: Critical sections are typically heavy sections. Section changes, high-stress points such as drilled lubrication points, the rotor bores, and flanges. Normally, bosses and similar sections are not considered critical sections of a casting. If critical sections of a casting have different thicknesses average size keel or Y blocks may be selected in accordance with ASTM A 395 or other internationally recognized material specifications. Minimum quality levels should be agreed upon between the purchaser and the vendor.

**5.11.2.6.2** A minimum of one set (three samples) of Charpy V-notch impact specimens at one-third the thickness of the test block shall be made from the material adjacent to the tensile specimen on each keel or Y-block. All three specimens shall have an impact value not less than 11 joules (8.1 foot-pounds) and the mean of the three specimens shall not be less than 14 joules (10 foot-pounds) at room temperature.

**5.11.2.6.3** An "as-cast" sample from each ladle shall be chemically analyzed.

**5.11.2.6.4** Ductile iron may be repaired by plugging within the limits specified in ASTM A 395, or A 536. The holes drilled for plugs shall be carefully examined, using liquid penetrant, to ensure that all defective material has been removed.

**5.11.2.6.5** Brinell hardness tests shall be made on the actual casting at feasible critical sections such as section changes, flanges, and other accessible locations such as the casing bore. Sufficient surface material shall be removed before hardness tests are made to eliminate any skin effect. Tests shall also be made at the extremities of the casting at locations that represent the sections poured first and last. These shall be made in addition to hardness test on keel or Y blocks in accordance with 5.11.2.6.1.

### 5.11.3 Forgings

**5.11.3.1** Unless otherwise agreed upon by the purchaser and the vendor, the forging material shall be selected from those listed in Annex F.

**5.11.3.2** All repairs that are not covered by ASTM or other specified internationally recognized material specifications shall be subject to the purchaser's approval.

### 5.11.4 Welding

- **5.11.4.1** Welding and weld repairs shall be performed and inspected by operators and procedures qualified in accordance with the requirements of Table 7. If specified, alternate codes or standards, welding codes or standards may be used.

**Table 7—Welding requirements**

Requirement	Applicable Code or Standard
Welder/operator qualification for piping, pressure-containing parts, rotating parts and other highly stressed parts.	ASME Code Section IX.
Welding procedure qualification for piping, pressure-containing parts, rotating parts and other highly stressed parts.	Applicable material specification or, where weld procedures are not covered by the material specification, ASME Code Section IX.
Non-pressure retaining structural welding such as baseplates or supports.	ANSI/AWS D1.1.
Magnetic particle or liquid penetrant examination of the plate edges.	ASME Code Section VIII, Division 1, UG-93(d)(3).
Postweld heat treatment.	Applicable material specification or ASME Code Section VIII, Division 1, UW 40.
Postweld heat treatment of casing fabrication welds.	Applicable material specification or ASME Code Section VIII, Division I.

**5.11.4.2** The vendor shall be responsible for the review of all repairs and repair welds to ensure that they are properly heat treated and nondestructively examined for soundness and compliance with the applicable qualified procedures. Repair welds shall be nondestructively tested by the same method used to detect the original flaw, however, the minimum level of inspection after the repair shall be by the magnetic particle method in accordance with 7.2.2.4 for magnetic material and by the liquid penetrant method in accordance with 7.2.2.5 for nonmagnetic material. Unless otherwise specified, procedures for major repairs shall be subject to review by the purchaser before any repair is made.

**5.11.4.2.1** The purchaser shall be notified before making a major repair. Major repair, for the purpose of purchaser notification is any defect that equals or exceeds any of the following criteria:

- a) A repair of any moving part.
- b) A repair of a pressure-containing part in which the depth of the cavity prepared for repair welding exceeds 50% of the component wall thickness, or is longer than 150 mm (6 in) in any direction.
- c) Where the total area of all repairs to the part under repair exceeds 10% of the surface area of the part.

**5.11.4.3** All accessible areas of welds on built-up rotors shall be inspected by means of magnetic particle or dye penetrant examination.

**5.11.4.4** Pressure-containing casings made from wrought materials or combinations of wrought and cast materials shall conform to the conditions specified in 5.11.4.4.1 through 5.11.4.4.4.

**5.11.4.4.1** Plate edges shall be inspected by magnetic particle or liquid penetrant examination as required by 5.11.4.1 and Table 7.

**5.11.4.4.2** Accessible surfaces of welds shall be inspected by magnetic particle or liquid penetrant examination after back chipping or gouging and again after post-weld heat treatment.

**5.11.4.4.3** Pressure containing welds, including welds of the case to axial- and radial-joint flanges, shall be full penetration welds.

**5.11.4.4.4** Casings fabricated from materials that, according to the specified pressure design code require post-weld heat treatment, shall be heat treated regardless of thickness.

**5.11.4.5** Connections welded to pressure casings shall be installed as specified in 5.11.4.5.1 through 5.11.4.5.5.

- **5.11.4.5.1** In addition to the requirements in 5.11.4.1 specific welds shall be subjected to 100% radiography, magnetic particle inspection, ultrasonic inspection or liquid penetrant inspection if specified.

- **5.11.4.5.2** If specified, proposed connection designs shall be submitted for approval before fabrication. The drawings shall show weld designs, size, materials and pre- and post-weld heat treatments.

**5.11.4.5.3** All welds shall be heat treated in accordance with 5.11.4.1 and Table 7.

**5.11.4.5.4** Post-weld heat treatment, when required, shall be carried out after all welds, including piping welds, have been completed.

**5.11.4.5.5** Auxiliary piping welded to alloy steel casings shall be of a material with the same nominal properties as the casing material or shall be of low carbon austenitic stainless steel. Other materials compatible with the casing material and intended service may be used with the purchaser's approval.

### 5.11.5 Low temperature service

- **5.11.5.1** The purchaser shall specify the minimum design metal temperature and concurrent pressure used to establish impact test and other material requirements.

Note: Normally, this will be the lower of the minimum surrounding ambient temperature or minimum process fluids temperature; however, the purchaser may specify a minimum metal temperature based on properties of the process fluids, such as auto-refrigeration at reduced pressures.

**5.11.5.2** To avoid brittle failures, materials and construction for low temperature service shall be suitable for the minimum design metal temperature in accordance with the codes and other requirements specified. The purchaser and the vendor shall agree on any special precautions necessary with regard to conditions that may occur during operation, maintenance, transportation, erection, commissioning and testing.

Note: Care should be taken in the selection of fabrication methods, welding procedures and materials for vendor furnished steel pressure retaining parts that may be subject to temperature below the ductile-brittle transition point.

The published design-allowable stresses for many materials in internationally recognized standards such as the ASME Code and ANSI standards are based on minimum tensile properties. Some standards do not differentiate between rimmed, semi-killed, fully-killed, hot-rolled and normalized material, nor do they take into account whether materials were produced under fine or coarse grain practices. The vendor should exercise caution in the selection of materials intended for services between  $-30^{\circ}\text{C}$  ( $-20^{\circ}\text{F}$ ) and  $40^{\circ}\text{C}$  ( $100^{\circ}\text{F}$ ).

**5.11.5.3** All carbon, low alloy and high alloy steel pressure containing components including nozzles, flanges and weldments shall be impact tested in accordance with the requirements of the specified pressure design code. For materials and thicknesses not covered by the specified pressure design code, the purchaser should specify requirements.

Note: Impact testing of a material may not be required depending on the minimum design metal temperature, thermal, mechanical and cyclic loading and the governing thickness. Refer to requirements of Section VIII, Division I, Section UG-20F of the ASME Code, for example.

Governing thickness used to determine impact testing requirements shall be the greater of the following:

- a) The nominal thickness of the largest butt welded joint.
- b) The largest nominal section for pressure containment, excluding:
  1. Structural support sections such as feet or lugs.
  2. Sections with increased thickness required for rigidity to mitigate shaft deflection.
  3. Structural sections required for attachment or inclusion of mechanical features such as jackets or seal chambers.
- c) One fourth of the nominal flange thickness, including parting flange thickness for axially split casings (in recognition that the predominant flange stress is not a membrane stress).

The results of the impact testing shall meet the minimum impact energy requirements of the specified pressure design code.

## 5.12 Nameplates and rotation arrows

**5.12.1** A nameplate shall be securely attached at a readily visible location on the equipment and on any major piece of auxiliary equipment.

**5.12.2** Rotation arrows shall be cast in or attached to each major item of rotating equipment at a readily visible location.

**5.12.3** Nameplates and rotation arrows (if attached) shall be of austenitic stainless steel or of nickel-copper (UNS N04400) alloy. Attachment pins shall be of the same material. Welding is not permitted.

**5.12.4** The following data shall be clearly stamped or engraved on the nameplate:

- a) Vendor's Name
- b) Serial Number
- c) Size, type and model
- d) Rated Capacity
- e) Purchaser item number or other reference
- f) Maximum continuous speed
- g) Maximum allowable casing working pressure
- h) Hydrostatic test pressure
- i) Maximum allowable temperature

## 5.13 Quality

Refer to API Recommended Practice 683 for guidelines on a quality assurance program for the equipment.

## 6 Accessories

### 6.1 Drivers

#### 6.1.1 General

**6.1.1.1** The driver shall be of the type specified, shall be sized to meet the maximum specified operating conditions, including external gear and coupling losses, and shall be in accordance with applicable specifications, as stated in the inquiry and order. The driver shall operate under the utility and site conditions specified in the inquiry.

**6.1.1.2** The driver shall be sized to accept any specified process variations such as changes in the pressure, temperature or properties of the fluids handled, and plant start-up conditions.

**6.1.1.3** The driver shall be capable of starting under the conditions specified and the starting method shall be agreed by the purchaser and the vendor. The driver's starting-torque capabilities shall exceed the speed-torque requirements of the driven equipment.

**6.1.1.4** The supporting feet of drivers with a weight greater than 225 kg, (500 lbs) shall be provided with vertical jackscrews.

#### 6.1.2 Motors

- **6.1.2.1** The purchaser shall specify the type of motor and its characteristics and accessories, including but not limited to the following:
  - a) Electrical characteristics.
  - b) Starting conditions (including the expected voltage drop on starting).
  - c) The type of enclosure.
  - d) The sound pressure level.
  - e) The area classification, based on API Recommended Practice 500 or equivalent international standard.

- f) The type of insulation.
- g) The required service factor.
- h) The ambient temperature and elevation above sea level.
- i) Transmission losses.
- j) Temperature detectors, vibration sensors, and heaters specified.
- k) Auxiliaries (such as motor-generator sets, ventilation blowers, and instrumentation).
- l) Vibration acceptance criteria.
- m) Use in variable frequency drive applications.

**6.1.2.2** Motor drives shall conform to Internationally recognized standards such as API Standard 541 or 546 as applicable. (Motors that are below the power scope of API Standard 541 or 546 shall be in accordance with IEEE 841). Electric motor drivers shall be rated with a 1.0 service factor. The motor rating shall be at least 110% of the greatest power required (including gear and coupling losses) for any of the specified operating conditions. Consideration shall be given to the starting conditions of both the driver and driven equipment and the possibility that these conditions may be different from the normal operating conditions.

Note: The 110% applies to the design phase of a project. After testing, this margin might not be available due to performance tolerances of the driven equipment.

**6.1.2.3** The motor's starting torque shall meet the requirements of the driven equipment, at a reduced voltage of 80% of the normal voltage, or such other value as may be specified, and the motor shall accelerate to full speed within 15 seconds or such other period of time agreed upon by the purchaser and the vendor.

### 6.1.3 Steam turbines

- **6.1.3.1** Steam turbine drivers shall conform to ISO 10436 or ISO 10437 (API Standards 611 or 612). Steam turbine drivers shall be sized (rated) to deliver continuously not less than 110% of the maximum power requirement of the driven equipment, (including any gear and coupling losses) when operating at any of the specified operating conditions and at the corresponding speed. Steam turbine drivers shall deliver their rated power at the corresponding speed with coincident minimum inlet and maximum exhaust conditions as specified by the purchaser.

Note 1: The 110% applies to the design phase of the project. After testing, this margin might not be available due to performance tolerances of the driven equipment.

Note 2: To prevent oversizing or to obtain higher operating efficiency or both, it may be desirable to limit maximum turbine capability by specifying normal power or a selected percentage of rated power instead of rated power at the minimum heat drop conditions specified.

### 6.1.4 Gear units

- **6.1.4.1** Gear units shall conform to ISO 13691 (API Standard 613) or API Standard 677 as specified.

## 6.2 Couplings and guards

**6.2.1** Unless otherwise specified, flexible couplings and guards between drivers and driven equipment shall be supplied by the manufacturer of the driven equipment.

**6.2.2** Couplings and guards shall conform to ISO 10441 (API Standard 671). The make, type, and mounting arrangement of couplings shall be agreed upon by the purchaser and the vendors of the driver and driven equipment.

**6.2.3** Information on shafts, keyway dimensions (if any), and shaft end movements due to end play and thermal effects shall be furnished to the vendor supplying the coupling.

Note: This information is normally furnished by the vendor of the driven equipment or the driver vendor.

**6.2.4** The coupling-to-shaft juncture shall be designed and manufactured to be capable of transmitting power at least equal to the power rating of the coupling.



**6.2.5** The purchaser of the coupling shall provide or include a moment simulator, if required for the mechanical running test (see 7.3.3).

Note: Test bed coupling mass should simulate the contract coupling moment.

## **6.3 Mounting plates**

### **6.3.1 General**

**6.3.1.1** The equipment shall be furnished with soleplates or a baseplate as specified.

**6.3.1.2** Mounting plates (baseplates and soleplates) shall comply with the requirements of 6.3.1.3 to 6.3.1.13.

Note: Refer to Annex G for typical mounting plate drawings.

**6.3.1.3** The upper and lower surfaces of mounting plates and any separate pedestals mounted thereon shall be machined parallel. The surface finish shall be 125 microns arithmetic average roughness or better.

**6.3.1.4** When an item of equipment supported has a mass in excess of 225 kg (500 lbs), the mounting plate or plates shall be furnished with horizontal (axial and lateral) jackscrews, the same size or larger than the vertical jackscrews. The lugs holding these jackscrews shall be attached to the mounting plates in such a manner that they do not interfere with the installation of the equipment, jackscrews or shims. Precautions shall be taken to prevent vertical jackscrews in the equipment feet from marring the shimming surfaces. Alternative methods of lifting equipment for the removal or insertion of shims or for moving equipment horizontally, such as provision for the use of hydraulic jacks, may be proposed. Such arrangements should be proposed for equipment that is too heavy to be lifted or moved horizontally using jackscrews. Jack screws shall be plated for rust resistance.

**6.3.1.5** Machinery supports shall be designed to limit the relative displacement of the shaft end caused by the worst combination of pressure, torque and allowable piping stress, to 50  $\mu\text{m}$  (0.002 in). (See Annex C for allowable piping loads).

**6.3.1.6** When pedestals or similar structures are provided for centerline supported equipment, the pedestals shall be designed and fabricated to permit the machine to be moved using horizontal jackscrews.

**6.3.1.7** Unless otherwise specified, epoxy grout shall be used for machines mounted on concrete foundations. Grouting preparation and installation shall be in accordance with API Recommended Practice 686 Chapter 5.

**6.3.1.8** The anchor bolts shall not be used to fasten equipment to the mounting plates.

**6.3.1.9** Mounting plates shall conform to the following:

- a) Mounting plates shall not be drilled for equipment to be mounted by others.
- b) Mounting plates shall be supplied with leveling screws. Tapered blocks for leveling may be supplied instead of leveling screws if approved by the purchaser.
- c) Outside corners of mounting plates which are in contact with the grout shall have 50 mm (2 in) minimum radiused outside corners (in the plan view).
- d) All machinery mounting surfaces shall be treated with a rust preventive immediately after machining.
- e) Mounting plates shall extend at least 25 mm (1 in) beyond the outer three sides of equipment feet.
- f) Mounting plates shall be machined to a finish of 6.3  $\mu\text{m}$  (250  $\mu\text{in}$ ) arithmetic average roughness (Ra) or better.

**6.3.1.10** The alignment shims shall be in accordance with API Recommended Practice 686 Chapter 7 and shall straddle the hold-down bolts and vertical jackscrews and be at least 5 mm ( $\frac{1}{4}$  in) larger on all sides than the equipment feet.

**6.3.1.11** Unless otherwise specified, anchor bolts will be furnished by the purchaser.

**6.3.1.12** Hold down bolts used to attach the equipment to the mounting plates and all jackscrews, shall be supplied by the vendor.

**6.3.1.13** Equipment shall be designed for installation in accordance with API Recommended Practice 686.

### 6.3.2 Baseplates

**6.3.2.1** If a baseplate is specified, the purchaser shall indicate the major equipment to be mounted on it. A baseplate shall be a single fabricated steel unit, unless the purchaser and the vendor mutually agree that it may be fabricated in multiple sections. Multiple-section baseplates shall have machined and doweled mating surfaces which shall be bolted together to ensure accurate field reassembly.

Note: A baseplate with a nominal length of more than 12 m (40 ft) or a nominal width of more than 4 m (12 ft) may have to be fabricated in multiple sections because of shipping restrictions.

**6.3.2.2** If a baseplate(s) is provided, it shall extend under the drive-train components so that any leakage from these components is contained within the baseplate.

- **6.3.2.3** If specified, the baseplate shall be designed to facilitate the use of optical, laser-based or other instruments for accurate leveling in the field. The details of such facilities shall be agreed by the purchaser and vendor. Where the requirement is satisfied by the provisions of leveling pads and/or targets, they shall be accessible with the baseplate on the foundation and the equipment mounted. Removable protective covers shall be provided. For column-mounted baseplates (see 6.3.2.4) leveling pads or targets shall be located close to the support points. For non column mounted baseplates, a pad or target should be located at each corner. When required for long units, additional pads shall be located at intermediate points.
- **6.3.2.4** If specified, the baseplate shall be designed for column mounting (that is, of sufficient rigidity to be supported at specified points ) without continuous grouting under structural members. The baseplate design shall be mutually agreed upon by the purchaser and the vendor.

**6.3.2.5** The baseplate shall be provided with lifting lugs for at least a four-point lift. Lifting the baseplate complete with all equipment mounted shall not permanently distort or otherwise damage the baseplate or the equipment mounted on it.

**6.3.2.6** The bottom of the baseplate between structural members shall be open, except when an oil reservoir integral with the base plate is supplied. When the baseplate is designed for grouting, it shall be provided with at least one grout hole having a clear area of at least 130 cm<sup>2</sup> (20 in<sup>2</sup>) and no dimension less than 75 mm (3 in) in each bulkhead section. These holes shall be located to permit grouting under all load-carrying structural members. Where practical, the holes shall be accessible for grouting with the equipment installed. The holes shall have 13 mm (0.5 in) raised-lip edges, and if located in an area where liquids could impinge on the exposed grout, metallic covers with a minimum thickness of 1.5 mm (0.060 in) shall be provided. Vent holes at least 13 mm (0.5 in) in size shall be provided at the highest point in each bulkhead section of the baseplate.

**6.3.2.7** Unless otherwise specified, nonskid metal decking covering all walk and work areas shall be provided on the top of the baseplate.

**6.3.2.8** The underside mounting surfaces of the baseplate shall be in one plane within 0.1 mm (0.004 in).

Note: Mounting surfaces in one plane permit use of single-level foundation.

**6.3.2.9** All upper baseplate mounting surfaces shall:

- a) be machined after the baseplate is fabricated;
- b) for a single machine casing each group of mounting surfaces required to be in the same horizontal plane shall be so within 25 µm (0.001 in) to prevent a soft foot;
- c) each mounting surface shall be machined within a flatness of 4.2 µm per 100 mm (0.0005 in per ft) of mounting surface;
- d) different mounting planes shall be parallel to each other within 50 µm (0.002 in).

### 6.3.3 Soleplates and subsoleplates

- **6.3.3.1** If soleplates are specified, they shall meet the requirements of 6.3.3.1.1 and 6.3.3.1.2 in addition to those of 6.3.1.

**6.3.3.1.1** Adequate working clearance shall be provided at the bolting locations to allow the use of standard socket or box wrenches and to allow the equipment to be moved using the horizontal and vertical jackscrews.

**6.3.3.1.2** Soleplates shall be steel plates that are thick enough to transmit the expected loads from the equipment feet to the foundation, but in no case shall the plates be less than 40 mm (1½ in) thick.

- **6.3.3.2** If specified, subsoleplates shall be provided by the vendor.

**6.3.3.2.1** If subsoleplates are specified, they shall be steel plates at least 25 mm (1 in) thick. The finish of the subsoleplates' mating surfaces shall match that of the soleplates (see 6.3.1.3).

## 6.4 Controls and instrumentation

### 6.4.1 General

- **6.4.1.1** The vendor shall provide sufficient compressor performance data to enable the purchaser to properly design a control system for start-up and for all specified operating conditions. When requested by the purchaser, the vendor shall review the purchaser's overall compressor control system for compatibility with vendor-furnished control equipment.

**6.4.1.2** Instrumentation and installation shall conform to the purchaser's specifications, and, unless otherwise specified, instrumentation and installation shall conform to the requirements of API Standard 614.

- **6.4.1.3** The purchaser shall specify controls, instruments, and control panel requirements on API Standard 614 data sheets.

Note: API 614 Data Sheet may be used to specify the requirements.

**6.4.1.4** Unless otherwise specified, controls and instrumentation shall be designed for outdoor installation and shall meet the requirements of IP65 as detailed in IEC 60079 (NEMA 4, Publication 250).

**6.4.1.5** Controls and instrumentation shall be designed and manufactured for use in the area classification (class, group, and division or zone) specified.

**6.4.1.6** All conduit, armored cable and supports shall be designed and installed so that it can be easily removed without damage and shall be located so that it does not hamper removal of bearings, seals, or equipment internals.

### 6.4.2 Control systems

- **6.4.2.1** The compressor may be controlled on the basis of inlet pressure, discharge pressure, flow or some combination of these parameters. This may be accomplished by suction throttling, speed variation, slide valve volume control device or a cooled bypass from discharge to suction. The control system may be mechanical, pneumatic, hydraulic, electric or any combination thereof. The system may be manual or it may be automatic with a manual override. The purchaser shall specify the source of the control signal, its sensitivity and range, and the equipment to be furnished by the vendor.

Note: For flooded screw compressors the bypass may not require cooling.

**6.4.2.2** For a variable-speed drive, the control signal shall act to adjust the set point of the driver's speed-control system. The speed of the machine shall vary linearly and directly with the control signal. Unless otherwise specified, the control and operating speed range shall be from maximum continuous speed to 95% of the minimum speed required for any specified operating condition or 70% of the maximum continuous speed, whichever is lower.

- **6.4.2.3** If specified, a combination of control modes shall be provided.

Note: Typically, this will be necessary on machines with a limited speed range, on multiservice or multistream applications.

- **6.4.2.4** If constant-speed drive is specified, the control signal shall actuate the slide valve volume control device if furnished, or the control valve in the compressor piping.

**6.4.2.5** The full range of the specified control signal will correspond to the required operating range of the driven equipment. Unless otherwise specified, the maximum control signal shall correspond to the maximum continuous speed or the maximum flow.

### 6.4.3 Instrument and control panels

- **6.4.3.1** If specified, a panel shall be provided and shall include all panel-mounted instruments for the driven equipment and the driver. Such panels shall be designed and fabricated in accordance with the purchaser's description. The panel is to be freestanding, located on the base of the unit, or in another location, as specified. The instruments on the panel shall be clearly visible to the operator from the driver control point. A lamp test push button shall be provided. The instruments to be mounted on the panel will be specified.
- **6.4.3.2** Unless otherwise specified, panels shall be made of steel plate at least 3 mm ( $\frac{1}{8}$  in) thick, reinforced, self-supporting and closed on the top and sides. When specified the backs of panels shall be closed to minimize electrical hazards, to prevent tampering or to allow purging for safety or corrosion protection. All instruments shall be flush mounted on the front of the panel and all fasteners shall be of corrosion resistant material.

**6.4.3.3** Panels shall be completely assembled, piped and wired, requiring only connection to the purchaser's external piping and wiring circuits. When more than one wiring point is required on a unit for control or instrumentation, the wiring to each switch or instrument shall be provided from a single terminal box, with terminal posts. Each box shall be mounted on the unit or its base if any. All leads and posts on terminal strips, switches and instruments shall be tagged for identification. Wiring inside panels shall be neatly run in conduits or supported on cable trays.

**6.4.3.4** Interconnecting piping, tubing or wiring for controls and instrumentation, furnished by the vendor, shall be disassembled only to the extent necessary for shipment.

### 6.4.4 Instrumentation

#### 6.4.4.1 General

For all instrument types the purchaser shall specify the hardware connection from the measurement point through to the instrument.

#### 6.4.4.2 Tachometers

- If specified, a tachometer shall be provided for variable speed units. The type, range and indicator provisions shall be as specified. Unless otherwise agreed, the tachometer shall be supplied by the driver vendor and shall be furnished with a minimum range of 0 – 125% of maximum continuous speed.

#### 6.4.4.3 Vibration and position detectors

- **6.4.4.3.1** If specified, noncontacting vibration and axial-position transducers shall be supplied, installed, and calibrated in accordance with API Standard 670.
- **6.4.4.3.2** If specified, seismic vibration transducers shall be supplied, installed, and calibrated in accordance with API Standard 670.
- **6.4.4.3.3** If specified, vibration, axial position, and seismic monitors shall be supplied and calibrated in accordance with API Standard 670.

#### 6.4.4.4 Bearing temperature monitor

If specified, a bearing temperature monitor shall be supplied and calibrated in accordance with API Standard 670.

Note: Due to size restrictions it may not be possible to incorporate bearing temperature monitoring on smaller models of compressors. On oil-flooded screw compressors bearing temperature monitoring may not be practical.

#### 6.4.4.5 Slide valve position indicator

If slide valves are supplied, instrumentation shall be provided to indicate the position of the slide valve.

#### 6.4.4.6 Relief valves

**6.4.4.6.1** The vendor shall furnish the relief valves that are to be installed on equipment or piping that the vendor is supplying. Other relief valves related to equipment or piping outside the system that the vendor is supplying, should be furnished by the purchaser. The vendor's quotation shall list all relief valves and shall clearly state that these valves will be furnished by the vendor.

**6.4.4.6.2** The sizing, selection and installation of relief valves shall meet the requirements of API Recommended Practice 520, Parts I and II. Relief valves shall be in accordance with API Standard 526. The vendor shall determine the size and set pressure of all relief valves within his scope of supply and recommend the size and setting of relief valves supplied by others required to protect the equipment he supplies. Relief valve sizes and settings shall take into account all possible modes of equipment failure.

**6.4.4.6.3** Unless otherwise specified, relief valves shall have steel bodies.

- **6.4.4.6.4** If specified, thermal relief valves shall be provided for accessories or cooling jackets that may be blocked-in by isolation valves.

- **6.4.4.7 Compressor depressurization valve**

If specified, the vendor shall supply a depressurization valve installed in the piping system.

- **6.4.4.8 Shutdown isolation valves**

If specified, the vendor shall supply shutdown isolation valves at both suction and discharge gas termination points.

Note: Start-up with closed isolation valves may not be possible due to small enclosed volume or high settle-out pressure.

#### 6.4.4.9 Flow indicators

**6.4.4.9.1** Flow indicators shall be furnished in each atmospheric oil-drain return line.

**6.4.4.9.2** Unless otherwise specified, the flow indicator shall be:

- Flanged.
- Bulls-eye-type with glass on both sides.
- Steel body construction.
- Diameter of not less than one half the inside diameter of the oil pipe.
- Capable of clearly showing the minimum oil flow.

Note: To facilitate viewing of the flow of oil through the line, each flow indicator should be installed with its bullseye-glass in a vertical plane.

#### 6.4.5 Alarms and shutdowns

##### 6.4.5.1 General

**6.4.5.1.1** An alarm/shutdown system shall be provided which will initiate an alarm if any one of the specified parameters reaches an alarm point and will initiate shutdown of the equipment if any one of the specified parameters reaches the shutdown point.

- **6.4.5.1.2** The purchaser should specify the alarms and trips required which may include those listed in Table 8.

**Table 8—Conditions requiring alarms only or alarms and shutdowns****Condition:**

Axial position movement  
 Overspeed  
 Unit shutdown  
 Operation of spare lube-oil pump  
 Operation of spare seal-oil pump  
 High radial shaft vibration  
 High casing or bearing housing vibration  
 High winding temperature  
 High bearing temperature  
 High compressor discharge temperature  
 High gas differential pressure  
 High inlet-air-filter differential pressure  
 High level on separators  
 High lube-oil-filter differential pressure  
 High seal-oil-filter differential pressure  
 High thrust-bearing drain temperature  
 High or low lube-oil temperature  
 High or low lube-oil reservoir level  
 High or low seal-oil pressure  
 High or low seal-oil temperature  
 High or low seal-oil reservoir level  
 Low coolant flow to compressor jacket  
 Low buffer-gas pressure  
 Low lube-oil pressure

**6.4.5.1.3** The vendor shall advise the purchaser of any additional alarms and/or shutdowns considered essential to safeguard the equipment.

- **6.4.5.1.4** The purchaser shall specify the extent to which this alarm/shutdown system is to be supplied by the equipment vendor.

**6.4.5.1.5** Unless otherwise specified, the necessary valving and switches or bridging links shall be provided to enable all instruments and other components, except shutdown sensing devices, to be replaced with the equipment in operation. When isolation valves are specified for shutdown sensing devices, the vendor shall provide means of locking the valves in the open position.

**6.4.5.2 Alarms**

**6.4.5.2.1** It is accepted that with some systems, particularly those based on conventional direct acting instruments, complete compliance with the requirements of 6.4.5.2.2 through 6.4.5.2.9 may not be achievable.

**6.4.5.2.2** For every shutdown parameter an alarm shall be provided with the alarm point set at a lesser deviation from the normal condition than the associated shutdown point.

- **6.4.5.2.3** Any alarm parameter, reaching the alarm point, shall initiate an audible warning or flashing light or both as specified. It shall be possible to determine which parameter initiated the alarm.
- **6.4.5.2.4** Any shutdown parameter, reaching the shutdown point, shall cause the equipment to shutdown and shall initiate an audible warning or a flashing light or both as specified which shall be distinguishable from those associated with an alarm. It shall be possible to determine which parameter initiated the shutdown.

**6.4.5.2.5** When any component of the alarm/shutdown system malfunctions an alarm shall be initiated and shall be distinguishable from alarms resulting from malfunction of the equipment.

Note: To accomplish this redundant sensors may be required.

**6.4.5.2.6** When any malfunction of a component of the shutdown system results in the system being unable to recognize a shutdown condition, the equipment shall automatically shutdown and an alarm shall be initiated. This alarm shall be distinguishable from shutdowns resulting from malfunction of the equipment (fail-safe system).

- **6.4.5.2.7** When a non-fail-safe system is specified, a failure that results in the system being unable to recognize an alarm condition shall also result in all other alarms and shutdowns remaining functional.

**6.4.5.2.8** It shall be possible to test every component of every alarm function while the equipment is in operation. Such testing shall not require the disarming of any shutdown function.

**6.4.5.2.9** With the exception of the final shutdown device (circuit breaker, steam trip and throttle valve, fuel valve, etc.), it shall be possible to test every component of every shutdown function while the equipment is in operation. The testing of components associated with a shutdown function shall not require disarming of any other shutdown function nor any alarm function.

Note 1: This allows all alarms to be bypassed during testing of switches.

Note 2: To accomplish this redundant sensors may be required.

### **6.4.5.3 Event recorder**

- If specified, the alarm/shutdown system shall incorporate an event recorder to record the order of occurrence of alarms and shutdowns.

Note: The special event recorder normally associated with a distributed control system (DCS) may not have a sufficiently fast scanning rate.

### **6.4.5.4 Annunciator**

- **6.4.5.4.1** If specified, the alarm/shutdown system shall incorporate a first-out annunciator facility to indicate which parameter first reached the alarm level and which parameter first reached the shutdown level, in the event that multiple alarms and/or shutdown result from a single initial event. Where this facility is not incorporated as part of an integrated control and monitoring system, a separate annunciator instrument shall be provided.

**6.4.5.4.2** If a first-out annunciator feature is specified, whether as a separate instrument or incorporated into an integrated control and monitoring facility, the sequence of operation shall be as follows:

- a) The first parameter to reach alarm or shutdown shall cause the flashing of a light and the sounding of an audible device.
- b) The alarm or shutdown condition shall be acknowledged by operating an alarm silencing button, common to all alarms and shutdowns.
- c) When the alarm or shutdown is acknowledged, the audible device shall be silenced but the light shall remain steadily lit as long as that alarm or shutdown condition exists.
- d) If another parameter reaches an alarm or shutdown level the light shall return to the flashing condition and the audible device shall sound, even if the previous alarm/shutdown condition has been acknowledged but still exists.

**6.4.5.4.3** If the first-out annunciator feature is provided by a separate instrument, this shall be mounted on a local panel. There shall be approximately 25% spare points and separate connections shall be provided for remote indication if any alarm operates or any shutdown operates.

### **6.4.5.5 Alarm and trip devices**

#### **6.4.5.5.1 General**

- The purchaser should specify whether individual alarm and trip devices are transmitters or switches.

Note: A transmitter is an instrument that sends the value of the measured variable signal to a remote end device, which takes appropriate action (such as alarm relay, display, process control computer).

### 6.4.5.5.2 Locally mounted switch initiation

**6.4.5.5.2.1** If alarm and/or shutdown functions are initiated by locally mounted switches, each alarm switch and each shutdown switch, except as noted in 6.4.5.10.2.7 and 6.4.5.10.2.8 shall be furnished in a separate housing located to facilitate inspection and maintenance.

**6.4.5.5.2.2** Hermetically sealed, single pole, double throw switches with a minimum capacity of 5 amperes at 120 volts AC and 0.5 ampere at 120 volts DC shall be provided. Mercury switches shall not be used.

- **6.4.5.5.2.3** The purchaser shall specify whether switches shall be connected to open (de-energize) or close (energize) to initiate alarms and shutdowns.

**6.4.5.5.2.4** Alarm and trip switches shall not be adjustable from outside the housing.

**6.4.5.5.2.5** Housings for alarm and shutdown switches shall comply with the requirements of 6.4.6.2.

- **6.4.5.5.2.6** The sensing elements of pressure switches shall be of stainless steel (AISI Standard Type 300 stainless steel). Low pressure switches, which are actuated by falling pressure, shall be equipped with a pressure gage, valved bleed or vent connection or, if specified a double block-and-bleed connection, to allow controlled depressurizing during testing. High pressure switches which are activated by rising pressure, shall be equipped with a valved test connection so that a portable pump can be used to raise the pressure during testing. The arrangement to be used should be specified by the purchaser.

**6.4.5.5.2.7** Temperatures shall be measured by thermocouples or resistance temperature detectors as specified and shall be connected to local panel mounted instruments. Multipoint instruments may be used except that alarms and shutdowns shall be connected to separate instruments and separate alarm or shutdown contacts (switches) shall be provided for each temperature monitored. Each alarm and shutdown level shall be separately adjustable.

**6.4.5.5.2.8** Vibration and/or axial position switches shall be provided by instruments complying with the requirements API 670 (see 6.4.4.3).

**6.4.5.5.2.9** Level switches shall be of the float or displacer type mounted in separate enclosures which can be isolated from the associated vessel. Valved test connections shall be provided to enable the level to be artificially raised or lowered as necessary to test the function of the switch.

## 6.4.6 Electrical systems

**6.4.6.1** Electrical systems shall be in accordance with API Standard 614.

**6.4.6.2** To guard against accidental contact, enclosures shall be provided for all terminal strips, relays, switches and other energized parts. Electrical power wiring shall be segregated from instrument and control signal wiring both externally and, as far as possible, inside enclosures. Inside enclosures which may be required to be opened with the equipment in operation, for example, for alarm testing or adjustment, shall be provided with secondary shields or covers for all terminal strips and other exposed parts carrying electrical potential in excess of 50 volts. Maintenance access space shall be provided around or adjacent to electrical equipment or in accordance with the appropriate code such as the National Electrical Code, Article 110.

## 6.5 Piping

### 6.5.1 General

**6.5.1.1** Piping design, joint fabrication, examination and inspection shall be in accordance with the codes and standards specified or, where no codes or standards have been specified, the appropriate recognized codes and standards. Welding of piping shall be performed by operators who are qualified, and using procedures qualified in accordance with the specified or internationally recognized standards, such as ASME B 31.3 and Section IX of the ASME Standard.



**6.5.1.2** Piping systems shall include piping, tubing where permitted, isolating valves, control valves, relief valves, pressure reducers, orifices, temperature gauges and thermowells, pressure gauges, sight flow indicators, and all related vents and drains.

**6.5.1.3** The vendor shall furnish all piping systems as specified, including mounted appurtenances, located within the confines of the main unit's skid base area, any oil console base area, or any auxiliary skid base area. The piping shall terminate with flanged connections at the edge of the skid base. When soleplates are specified for the equipment train, the extent of the piping system at the equipment train shall be defined by the purchaser. The purchaser should furnish only interconnecting piping between equipment groupings and off-skid base facilities.

**6.5.1.4** The design of piping systems shall achieve the following:

- a) Proper support and protection to prevent damage from vibration or from shipment, operation and maintenance.
- b) Proper flexibility and adequate accessibility for operation, maintenance and thorough cleaning.
- c) Installation in a neat and orderly arrangement adapted to the contours of the equipment without obstructing access areas.
- d) Elimination of air pockets by the use of valved vents or the use of non-accumulating piping arrangements.
- e) Complete drainage through low points without disassembly of piping.

**6.5.1.5** Piping shall preferably be fabricated by bending and welding to minimize the use of flanges and fittings. Flanges are permitted only at equipment connections, at the edge of any base and for ease of maintenance. The use of flanges at other points is permitted only with the purchaser's specific approval. Other than tees and reducers, welded fittings are permitted only to facilitate pipe layout in congested areas. Threaded connections shall not be used except (with the purchaser's approval) where essential for space or access reasons, Pipe bushings shall not be used.

**6.5.1.6** Pipe plugs shall be in accordance with 5.3.6

## **6.5.2 Auxiliary systems piping**

Unless otherwise specified, the auxiliary systems piping shall be in accordance with API 614. Unless otherwise specified, oil-supply piping and tubing, including fittings (excluding slip-on flanges), shall be stainless steel. For oil-flooded screw compressors, the material of piping upstream of oil filter shall be agreed by the purchaser and the vendor.

Note: Material of oil separator and piping upstream of oil filters in oil-flooded screw compressor systems is typically carbon steel.

## **6.5.3 Instrument piping**

Unless otherwise specified, the instrument piping shall be in accordance with API 614.

## **6.5.4 Process piping**

**6.5.4.1** The extent of and requirements for process piping to be supplied by the vendor shall be specified.

**6.5.4.2** The requirements of 6.5.1 shall apply to process piping supplied by the vendor.

- **6.5.4.3** If specified, the vendor shall review the design of all piping, appurtenances, and vessels (e.g. pulsation suppression devices, intercoolers, aftercoolers, separators, knockout drums, air intake filters and expansion joints) and supports immediately upstream and downstream of the equipment. The purchaser and the vendor shall agree on the scope of this review.

**6.5.4.4** For flooded screw compressors the interconnecting piping between the compressor discharge and the separator vessel shall be sized to run no more than half-full of liquid and shall be designed with a minimum slope of 1:24 to ensure drainage toward the separator.

## 6.6 Intercoolers and aftercoolers

- **6.6.1** If specified, the vendor shall furnish a water-cooled, shell-and-tube intercooler between each compression stage.
- **6.6.2** The purchaser shall specify whether aftercoolers shall be furnished by the vendor.
- **6.6.3** Water-cooled, shell-and-tube intercoolers and aftercoolers shall be designed and constructed in accordance with TEMA Class C or R, as specified by the purchaser on the data sheets. Intercoolers and aftercoolers shall be furnished in accordance with the specified pressure design code. When TEMA Class R is specified, the heat exchanger shall be in accordance with API Standard 660.

Note: Caution should be exercised regarding the susceptibility of heat exchangers and their supporting structures to pulsation-induced vibration.

**6.6.4** Unless otherwise approved by the purchaser, intercoolers and aftercoolers shall be constructed and arranged to allow removal of tube bundles without dismantling piping or compressor components. Water shall be on the tube side.

**6.6.5** Fixed-tube-sheet exchangers shall have inspection openings into their gas passages. Rupture disks on the shell side (to protect the shell in case of tube failures) shall be used only when specifically approved by the purchaser.

**6.6.6** When air coolers are specified, they shall be in accordance with API Standard 661.

**6.6.7** Unless otherwise specified, air-cooled heat exchangers used for intercoolers shall have automatic temperature control. This control may be accomplished by means of louvers, variable-speed fans, variable-pitch fans, bypass valves, or any combination of these. Proposed control systems will be approved by the purchaser.

**6.6.8** Unless otherwise specified, double-pipe intercoolers and aftercoolers may be furnished. A finned double-pipe design may be furnished only when specifically approved by the purchaser.

- **6.6.9** Intercoolers shall be either machine mounted or separately mounted, as specified.
- **6.6.10** Materials of construction shall be those specified on the data sheets.
- **6.6.11** When condensate separation and collection facilities are furnished by the vendor, they shall include the following:
  - a) An automatic drain trap with a manual bypass.
  - b) An armored gauge glass with isolation valves and blowdown valves on the collection pot.
  - c) Separate connections and level switches for high-level alarm and trip on the collection pot.
  - d) Collection pots sized to provide an agreed-upon holding capacity and a 5-minute time span between high-level alarm and trip, based on the expected normal liquid condensate rate.
  - e) Separate connections and level switches for the high-level alarm and trip on the collection pot.
- **6.6.12** If specified, the vendor shall furnish the fabricated piping between the compressor stages and the intercoolers and aftercoolers. Interstage piping shall conform to ASME B 31.3.

## 6.7 Inlet air filters

**6.7.1** Unless otherwise specified, the vendor shall furnish dry-type multistage high-efficiency air intake filters for air compressors taking suction from the atmosphere. High efficiency filters shall be capable of removing 97% of particles 1 micron or larger over the inlet capability range. The maximum clean filter pressure drop shall not exceed 5.0 in water gauge (12 millibar).

**6.7.2** Air inlet filters shall be suitable for mounting outdoors, preferably at grade, and shall be provided with a weather hood or louvers. For plant locations subject to unusual conditions, such as sandstorms, the inlet to the filter may be elevated some distance above the compressor.

- **6.7.3** Each filter shall be provided with a differential pressure indicating transmitter, or a differential pressure indicator and switch, as specified.

**6.7.4** Filters shall be designed such that the first-stage (prefilter) elements may be changed while the unit is operating.

Note: It should be recognized that many configurations and arrangements are available. Where specific filter features are desired, these will be in the purchaser's inquiry specifications or data sheets.

**6.7.5** Unless otherwise specified, inorganic zinc or hot-dipped galvanized coating is required for the filter frame and inlet piping.

## 6.8 Inlet separators

**6.8.1** Purchaser shall advise manufacturer of the quantity and type of any entrained liquid(s) or solid particles in the process gas stream.

Note 1: Solids not removed by the inlet separator pass through the oil-flooded screw compressor and will collect in the discharge gas/oil separator, and may damage the compressor's oil pump, rotor housing and rotors.

Note 2: Some contaminants, especially catalytic metal particles like iron, increase the rate of oil oxidation and may strip the oil of its polar additives (i.e. anti-wear and extreme pressure additives, plus rust and oxidation inhibitors, and dispersants).

- **6.8.2** If specified, the vendor shall furnish a high-efficiency inlet separator, for installation upstream of the compressor, to remove free liquids and solid particles from the process gas stream.

Notes:

1. Free liquids can excessively dilute the recirculated oil stream, particularly at start-up or upset conditions.
2. Free liquids can carry dissolved solids that will plate out due to evaporation from inlet pressure drop and compression heat.
3. Many solid particles are best removed in the inlet separator with the separated liquids.

**6.8.3** If an inlet filter/separator is specified, a differential pressure indicator and alarm switch shall be provided across the filter(s).

Note: It should be recognized that many configurations and arrangements are available. Where specific filter features are desired, these should be in the purchaser's inquiry specifications or data sheets.

**6.8.4** Unless otherwise specified, 300 series stainless steel or monel, vane or mesh type demister shall be furnished. When furnished, mesh type demisters shall be supported upstream and downstream of the mesh material.

## 6.9 Pulsation suppressors/silencers for dry screw compressors

### 6.9.1 General

The requirement for, and the scope of, an analysis of pulsation and noise suppression shall be agreed between the purchaser and the vendor.

Note 1: When designing the compressor and piping system, the entire operating range should be considered, including the entire speed range in variable speed applications, range of temperatures, pressures and variation of the gas conditions as well as intermittent operating conditions with purge gas.

Note 2: In screw compressor systems, the flow of gas is not steady, but moves through the piping in a series of flow pulses which are superimposed upon the steady (average) flow. The characteristics of the flow pulses are determined by the size and the operating conditions of the compressor (displacement, speed, rotors, pressures etc.). The mechanical and acoustical response from the piping system is a function of the amplitude and frequencies of the pulses, the thermo-physical properties of the gas and the piping system's characteristics (layout, supports, natural frequencies etc.).

Note 3: Screw compressors generate pulses that often are three-dimensional. Moreover, high frequencies combined with large diameter vessels or piping make circumferential modes more important to consider.

**6.9.2** Unless otherwise specified, inlet and exhaust pulsation suppressors/silencers for each casing shall be supplied by the compressor manufacturer. Their primary function shall be to provide the maximum practical reduction of pulsations in the frequency range of audible sound without exceeding the pressure drop limit specified in 6.9.3.

**6.9.3** Unless otherwise agreed, the pressure drop through the pulsation suppressors/silencers shall not exceed the following values:

- a) for suction silencers 1% of the absolute pressure at the pulsation suppressor/silencer inlet.
- b) for discharge silencers 2.5% of the absolute pressure at the pulsation suppressors/silencer discharge.

The pressure drop shall be stated in the datasheets and shall be accounted for in the calculation of the power required.

Note 1: in case of low pressure and vacuum applications, the pressure drop may exceed the 1% limit to achieve the necessary pulse attenuation.

Note 2: For machines with widely varying operating conditions (e.g. speed, gas mole weight) the above mentioned limits may not be achievable in all cases.

**6.9.4** The peak-to-peak pulsation levels on the process piping side of the inlet and discharge silencers shall not exceed 2 percent of the mean line absolute pressure or the value calculated from the following formula, whichever is smaller:

In SI units,  
 $P\% = 28.6 / (P^{1/3})$

In U.S. customary units,  
 $P\% = 15 / (P^{1/3})$

Where:

$P\%$  = maximum allowable peak-to-peak pulsation expressed as a percentage of the mean line-side absolute pressure.

$P$  = mean line-side pressure, in kilopascals absolute (pounds per square inch absolute).

**6.9.5** Pulsation suppressors/silencers shall be oriented with respect to the compressor flanges as mutually agreed by the purchaser and vendor.

Note: Maximum silencer efficiency results from mounting the pulsation suppressors/silencers directly on the compressor flanges.

**6.9.6** Pulsation suppressors and silencers should be of the externally lagged type. Alternative types may be considered, but full details of the proposed alternative type shall be submitted with the proposal.

**6.9.7** Unless otherwise agreed, diffusers or devices that split the gas flow through small orifices shall not be used in applications where contaminants present in the gas stream could build-up to ultimately obstruct the flow. However, if used, such devices should be easily accessible for cleaning.

- **6.9.8** If specified, the pulsation suppressor/silencer vendor shall supply detailed drawings to permit an independent study of the acoustical characteristics of the pulsation suppressor/silencers together with the purchaser's piping system.
- **6.9.9** The minimum corrosion allowance for carbon steel shells shall be 3 mm ( $1/8$  in). Where corrosive gases require the use of materials other than carbon steel, the material and any required corrosion allowance shall be specified by the purchaser. The purchaser shall specify on the data sheet the corrosion allowance for carbon steel or noncarbon steel material for the specified gas to be compressed. The thickness for noncarbon steel shell material shall be equal to or greater than the thickness required for carbon steel including the carbon steel corrosion allowance. Internals shall have a minimum thickness of 6 mm ( $1/4$  in).
- **6.9.10** Pulsation suppressors/silencers shall be in accordance with specified pressure design code and shall be suitable for not less than the specified relief valve setting. In addition to being designed for static conditions, the pulsation suppressors/silencers shall be designed for dynamic loads, considering the service cycles over the expected life of the vessel and the pulsing load characteristic.

**6.9.11** All welds shall be continuous full penetration.

**6.9.12** A DN 20 ( $\frac{3}{4}$  NPS) pressure test connection shall be provided at each pulsation suppressor/silencer inlet and outlet nozzle. A DN 25 (1 NPS) minimum external drain connection shall be provided for each compartment where liquids could collect while the compressor is in service. Where individual compartment drains are impracticable and bulkheads extend to the vessel wall, circular-notched openings in the bulkheads may be used with the purchaser's approval. The arrangement of internals shall ensure that liquids will flow to drain connections under all operating conditions. The effect of drain openings on silencer performance shall be considered.

**6.9.13** Unless otherwise specified, the inlet nozzle of inlet pulsation suppressor/silencer and the discharge nozzle of discharge pulsation suppressor/silencer shall be provided with two flanged DN 25 (1 NPS) connections located to permit, without interference, the purchaser's installation of dial thermometers and thermowells for high-temperature alarm or shutdown elements.

**6.9.14** Connections DN 40 (1- $\frac{1}{2}$  NPS) and smaller shall be gusseted in two planes to avoid breakage due to pulsation-induced vibration.

**6.9.15** Unless otherwise specified by the purchaser all main connections to pulsation suppressors/silencers shall be flanged.

- **6.9.16** If specified, inspection openings, DN 150 (6 NPS), complete with blind flanges and gaskets shall be provided for access to each compartment. DN 100 (4 NPS) inspection openings may be provided on vessels less than 500 mm (20 in) in diameter.

Note: Inspection openings may not be practical on some silencer designs.

**6.9.17** Side-entering main nozzle connections shall be reinforced with pad-type metal providing a metal area equal to the cutaway area (excluding the thickness of any metal present in the connection wall).

- **6.9.18** Construction shall be suitable for service in an outdoor location. If specified, insulation mounting clips on pulsation suppressors/silencers shall be provided. All connections and nameplates shall be unobstructed by the insulation.

## 6.10 Special tools

**6.10.1** When special tools or fixtures are required to disassemble, assemble or maintain the equipment, they shall be included in the quotation and furnished as part of the initial supply of the equipment. For multiple-unit installations, the requirements for quantities of special tools and fixtures shall be agreed between purchaser and vendor. These, or similar special tools shall be used, and their use demonstrated, during shop assembly and post test disassembly of the equipment.

**6.10.2** When special tools are provided, they shall be packaged in a separate, rugged metal box or boxes and shall be marked "special tools for (tag/item number)." Each tool shall be stamped or tagged to indicate its intended use.

## 7 Inspection, testing, and preparation for shipment

### 7.1 General

- **7.1.1** The purchaser should specify the extent of participation in the inspection and testing.
- **7.1.2** If specified, the purchaser's representative, the vendor's representative or both shall indicate compliance in accordance with the inspector's checklist (Annex H) by initialling, dating and submitting the completed checklist to the purchaser before shipment.

**7.1.3** After advance notification to the vendor, the purchaser's representative shall have entry to all vendor and subvendor plants where manufacturing, testing or inspection of the equipment is in progress.

**7.1.4** The vendor shall notify subvendors of the purchaser's inspection and testing requirements.

**7.1.5** If shop inspection and testing have been specified, the purchaser and the vendor shall coordinate manufacturing hold points and inspectors' visits.

**7.1.6** The purchaser should specify the amount of advance notification required for a witnessed or observed inspection or test.

## **7.2 Inspection**

### **7.2.1 General**

**7.2.1.1** The vendor shall keep the following data available for at least 20 years:

- a) Necessary or specified certification of materials, such as mill test reports.
- b) Test data and results to verify that the requirements of the specification have been met.
- c) Fully identified records of all heat treatment whether performed in the normal course of manufacture or as part of a repair procedure.
- d) Results of quality control tests and inspections.
- e) Details of all repairs.
- f) When specified, final assembly maintenance and running clearances.
- g) Other data specified by the purchaser or required by applicable codes and regulations. (See 4.4 and 8.3.1.1)

**7.2.1.2** Pressure-containing parts shall not be painted until the specified inspection and testing of the parts is complete.

Note: Some materials may require painting with primer to prevent corrosion.

- **7.2.1.3** In addition to the requirements of 5.11.4.1, the purchaser may specify the following:

- a) Parts that shall be subjected to surface and subsurface examination.
- b) The type of examination required, such as magnetic particle, liquid penetrant, radiographic and ultrasonic examination.

### **7.2.2 Material inspection**

#### **7.2.2.1 General**

**7.2.2.1.1** When radiographic, ultrasonic, magnetic particle or liquid penetrant inspection of welds or materials is required or specified, the criteria in 7.2.2.2 through 7.2.2.5 shall apply unless other corresponding procedures and acceptance criteria have been specified. Cast iron may be inspected only in accordance with 7.2.2.4 and/or 7.2.2.5. Welds, cast steel and wrought material shall be inspected in accordance with 7.2.2.2 through 7.2.2.5.2.

Note: Radiographic and ultrasonic inspection are not appropriate for cast iron.

**7.2.2.1.2** The vendor shall review the design of the equipment and impose more stringent criteria than the generalized limits required in 7.2.2, if necessary.

**7.2.2.1.3** Defects that exceed the limits imposed in section 7.2.2. shall be removed to meet the quality standards cited, as determined by the inspection method specified.

#### **7.2.2.2 Radiography**

**7.2.2.2.1** Radiography shall be in accordance with ASTM E 94.

**7.2.2.2.2** The acceptance standard used for welded fabrications shall be Section VIII, Division 1, UW-51 (for 100% radiography) and UW-52 (for spot radiography) of the ASME Code. The acceptance standard used for castings shall be Section VIII, Division 1, Appendix 7 of the ASME Code.

**7.2.2.3 Ultrasonic inspection**

**7.2.2.3.1** Ultrasonic inspection shall be in accordance with Section V, Articles 5 and 23, of the ASME Code.

**7.2.2.3.2** The acceptance standard used for welded fabrications shall be Section VIII, Division 1, Appendix 12, of the ASME Code. The acceptance standard used for castings shall be Section VIII, Division 1, Appendix 7, of the ASME Code.

**7.2.2.4 Magnetic particle inspection**

**7.2.2.4.1** Both wet and dry methods of magnetic particle inspection shall be in accordance with ASTM E 709.

**Table 9—Maximum severity of defects in castings**

Type	Defect	Maximum Severity Level
I	Linear Discontinuities	1
II	Shrinkage	2
III	Inclusions	2
IV	Chills and Chaplets	1
V	Porosity	1
VI	Welds	1

**7.2.2.5 Liquid penetrant inspection**

**7.2.2.5.1** Liquid penetrant inspection shall be in accordance with Section V, Article 6 of the ASME Code.

**7.2.2.5.2** The acceptance standard used for welded fabrications shall be Section VIII, Division 1, Appendix 8 and Section V, Article 24 of the ASME Code. The acceptance standard used for castings shall be Section VIII, Division 1, Appendix 7 of the ASME Code.

**7.2.3 Mechanical inspection**

**7.2.3.1** During assembly of the equipment, each component, (including integrally cast-in passages) and all piping and appurtenances shall be inspected to ensure they have been cleaned and are free of foreign materials, corrosion products and mill scale.

**7.2.3.2** All oil system components furnished shall meet the cleanliness requirements of API Standard 614.

- **7.2.3.3** If specified, the purchaser may inspect the equipment and all piping and appurtenances for cleanliness before heads are welded onto vessels, openings in vessels or exchangers are closed or piping is finally assembled.
- **7.2.3.4** If specified, the hardness of parts, welds and heat affected zones shall be verified as being within the allowable values by testing. The method, extent, documentation and witnessing of the testing shall be mutually agreed upon by the purchaser and the vendor.

**7.3 Testing**

**7.3.1 General**

**7.3.1.1** Equipment shall be tested in accordance with 7.3.2 and 7.3.3. Other tests that may be specified by the purchaser are described in 7.3.4.

**7.3.1.2** At least six weeks before the first scheduled running test, the vendor shall submit to the purchaser, for his review and comment, detailed procedures for the mechanical running test and all specified running optional tests (see 7.3.4), including acceptance criteria for all monitored parameters.

**7.3.1.3** The vendor shall notify the purchaser not less than 5 working days before the date the equipment will be ready for testing. If the testing is rescheduled, the vendor shall notify the purchaser not less than 5 working days before the new test date.

### **7.3.2 Hydrostatic tests**

**7.3.2.1** The pressure containing parts of the compressor casing shall be tested hydrostatically with liquid at a minimum of 1½ times the maximum allowable working pressure but not less than a gauge pressure of 1.5 bar (20 psig). The test liquid shall be at a higher temperature than the nil-ductility transition temperature of the material being tested. Reference ASTM E 1003.

Note 1: The nil ductility temperature is the highest temperature at which a material experiences complete brittle fracture without appreciable plastic deformation.

Note 2: For gas-pressure-containing parts, the hydrostatic test is a test of the mechanical integrity of the component and is not a valid leakage test.

**7.3.2.2** If the part tested is to operate at a temperature at which the strength of a material is below the strength of that material at the testing temperature, the hydrostatic test pressure shall be multiplied by a factor obtained by dividing the allowable working stress for the material at the testing temperature by that at the maximum allowable temperature. The stress values used shall conform to those given in ASME B31.3 for piping or in the specified pressure design code for vessels. The pressure thus obtained shall then be the minimum pressure at which the hydrostatic test shall be performed. The data sheets shall list actual hydrostatic test pressures.

Note: Applicability of this requirement to the material being tested should be verified before hydrotest, as the properties of many grades of steel do not change appreciably at temperatures up to 200°C (400°F).

**7.3.2.4** The chloride content of liquids used to test austenitic stainless steel materials shall not exceed 50 parts per million. To prevent deposition of chlorides on austenitic stainless steel as a result of evaporative drying, all residual liquid shall be removed from tested parts at the conclusion of the test.

Note: Chloride content is limited in order to prevent stress corrosion cracking.

**7.3.2.5** Tests shall be maintained for a sufficient period of time to permit complete examination of parts under pressure. The hydrostatic test shall be considered satisfactory when neither leaks nor seepage through the pressure containing parts or joints is observed for a minimum of 30 minutes. Large, heavy pressure containing parts or complex systems may require a longer testing period to be agreed upon by the purchaser and the vendor. Gaskets used during hydrotest of an assembled casing shall be of the same design as supplied with the casing.

### **7.3.3 Mechanical running test**

#### **7.3.3.1 Requirements prior to the mechanical running test**

**7.3.3.1.1** The contract shaft seals and bearings shall be used in the machine for the mechanical running test.

**7.3.3.1.2** All oil pressures, viscosities, and temperatures shall be within the range of operating values recommended in the vendor's operating instructions for the specific unit being tested. For pressure lubrication systems, oil flow rates for each bearing housing shall be measured.

**7.3.3.1.3** Test stand oil filtration shall be 10 µm at beta ratio 200 or better (see 5.10.3.7.1). Oil system components downstream of the filters shall meet the cleanliness requirements of ISO 10438 (API Standard 614) before any test is started.

**7.3.3.1.4** Bearings intended to be lubricated by an oil mist system shall be pre-lubricated.

**7.3.3.1.5** All joints and connections shall be checked for tightness, and any leaks shall be corrected.

**7.3.3.1.6** All warning, protective and control devices used during the test shall be checked and adjusted as required.

**7.3.3.1.7** Testing with the contract coupling or couplings is preferred.



**7.3.3.1.8** The vibration characteristics determined by the use of the instrumentation specified in 7.3.3.1.9 through 7.3.3.1.11 shall serve as the basis for acceptance or rejection of the machine (see 5.7.3.6).

**7.3.3.1.9** Shop test facilities shall include the capability of seismic monitoring of casing vibration.

Seismic vibration data, should be recorded in horizontal and vertical directions, at radial planes transverse to each bearing centerline, and also in axial direction, using shop instrumentation during the test.

Note: Compressor equipment configuration may limit measuring device location.

**7.3.3.1.10** All purchased vibration proximity probes, cables, oscillator-demodulators and seismic probes shall be in use during the test. If vibration probes are not furnished by the equipment vendor, or if the purchased probes are not compatible with shop readout facilities, then shop devices and readouts that meet the accuracy requirements of API Standard 670 shall be used.

**7.3.3.1.11** If vibration proximity probes are specified and supplied, shop test facilities shall include instrumentation with the capability of continuously monitoring and plotting revolutions per minute, peak-to-peak displacement, and phase angle (x-y-y'). Presentation of vibration displacement and phase marker shall also be by oscilloscope.

### **7.3.3.2 Speed requirements for the mechanical running test**

**7.3.3.2.1** The mechanical running test shall be run at maximum continuous speed for a minimum of 4 hours.

**7.3.3.2.2** Variable speed equipment shall be operated at speed increments of approximately 10% from minimum allowable speed to the maximum continuous speed and run at the maximum continuous speed until bearings, lube-oil temperatures and shaft vibrations have stabilized.

Note: Operating below minimum allowable speed will damage the equipment.

**7.3.3.2.3** The speed for variable speed equipment shall be increased to trip speed (See Table 1) and the equipment shall be run for a minimum of 15 minutes.

**7.3.3.2.4** The speed for variable speed equipment shall be reduced to the maximum continuous speed and the equipment shall be run continuously for 4 hours.

### **7.3.3.3 Requirements during the mechanical running test**

**7.3.3.3.1** During the mechanical running test, the mechanical operation of all equipment being tested and the operation of the test instrumentation shall be satisfactory. The measured vibration shall not exceed the limits specified in Table 3 or Table 4 as applicable and shall be recorded throughout the operating speed range.

**7.3.3.3.2** While the equipment is operating at maximum continuous speed and at other speeds that may have been specified in the test agenda, a spectrum analysis shall be made for vibration amplitudes at frequencies other than synchronous. As a minimum, this spectrum analysis shall cover a frequency range from 0.25 to 8 times the maximum continuous speed but not more than 90,000 cycles per minute (1,500 hertz). If the amplitude of any discrete, nonsynchronous vibration, excluding the frequency of the other rotor and its harmonics, exceeds 20% of the allowable overall vibration as defined in Table 3 or Table 4, or 75% of the allowable overall vibration in the case of the pocket passing frequency (PPF) and its harmonics, the purchaser and the vendor shall agree on requirements for any further investigation which may include additional testing.

Note 1: For screw compressors vibration at pocket passing frequency and its harmonics, or at the frequency of the other rotor and its harmonics, are common and may constitute the major part of the total vibration level as limited in 5.7.3.6.

Note 2: For high vibration at the PPF, or its harmonics, this additional testing may require closed loop testing simulating the contract molecular weight.

- **7.3.3.3.3** If specified, all real-time vibration data as agreed by the purchaser and vendor shall be recorded and a copy provided to the purchaser.
- **7.3.3.3.4** If specified, lube-oil and seal-oil inlet pressures and temperatures shall be varied through the range permitted in the operating manual. This shall be done during the 4-hour test.

### 7.3.3.4 Requirements after the mechanical running test is completed

**7.3.3.4.1** If replacement or modification of bearings or seals or dismantling of the case to replace or modify other parts is required to correct mechanical or performance deficiencies, the initial test will not be acceptable, and the final shop tests shall be run after these deficiencies are corrected.

**7.3.3.4.2** When spare rotors are ordered to permit concurrent manufacture, each spare rotor set shall also be given a mechanical running test in accordance with the requirements of this standard.

**7.3.3.4.3** After the mechanical running test is completed, each completely assembled compressor casing intended for toxic, hazardous, flammable, or hydrogen-rich service, or when specified for other gases, shall be tested as specified in 7.3.3.4.4 and 7.3.3.4.5.

**7.3.3.4.4** The casing (including end seals) shall be pressurized with an inert gas to the maximum sealing pressure or the maximum seal design pressure, as agreed by the purchaser and the vendor; held at this pressure for a minimum of 30 minutes, and subjected to a soap-bubble test or another approved test to check for gas leaks. The test shall be considered satisfactory when no casing or casing joint leaks are observed.

Note: Test gas mol weight should approximate contract gas mol weight. Helium for low mol weight contract gas and nitrogen or R<sub>22</sub> refrigerant gas for high mol weight should be considered.

**7.3.3.4.5** The casing (with or without end seals installed) shall be pressurized to the rated discharge pressure, held at this pressure for a minimum of 30 minutes, and subjected to a soap-bubble test or another approved method to check for gas leaks. The test shall be considered satisfactory when no casing or casing joint leaks are observed.

Note: The requirements of 7.3.3.4.4 and 7.3.3.4.5 may necessitate two separate tests.

### 7.3.3.5 Heat run

**7.3.3.5.1** For dry screw compressors a heat run shall be performed prior to the four hour mechanical test run. The compressor shall be run at the maximum continuous speed, with the discharge temperature stabilized at the maximum operating temperature at any of the specified operating conditions plus 11 K (20 R) for a minimum of 30 minutes.

Note 1: Heat run temperature relates to actual operating temperature at specified conditions, not relief valve settings, or maximum allowable operating temperature. Excessive internal clearances required for higher temperature operation result in decreased volumetric efficiency under normal operating conditions.

Note 2: On machines with water-flush seals and high leakage rates it may not be possible to achieve the heat run temperature.

Note 3: High discharge temperature shutdown point should be set below the heat run temperature.

**7.3.3.5.2** For compressors using oil-buffered seal units, when any test run with air will involve a discharge temperature above 120°C (250°F), the test shall be conducted using a modified procedure to eliminate the oil-air high-temperature hazard. The modified test procedure shall be agreed upon by the purchaser and the vendor.

## 7.3.4 Optional tests

### 7.3.4.1 General

If specified, the shop tests described in 7.3.4.2 through 7.3.4.13 shall be performed. Test details shall be mutually agreed upon by the purchaser and the vendor.

- **7.3.4.2 Performance test**

The machine shall be tested in accordance with ISO 1217. (See 5.1.15.a).

Vibration levels shall be measured and recorded during this test as specified in 7.3.3.1.9 through 7.3.3.1.11.

- **7.3.4.3 Complete unit test**

Such components as compressors, gears, drivers and auxiliaries that make up a complete unit shall be tested together during the mechanical running test. When specified, torsional vibration measurements shall be made to verify the vendor's analysis. For a torsional test it is necessary to include all main rotating components. The complete-unit test may be performed in place of or in addition to separate tests of individual components specified.

- **7.3.4.4 Deceleration test**

If proximity probes are specified, Synchronous vibration amplitude and phase angle versus speed for deceleration during coastdown shall be plotted before and after the 4-hour run. Both the filtered (one per revolution) and the unfiltered vibration levels shall also be plotted. If specified, these data shall also be furnished in polar form. The speed range covered by these plots shall be 400 rpm to the specified driver trip speed.

- **7.3.4.5 Tandem test**

Machines arranged for tandem drive shall be tested as a unit during the mechanical running test, using the shop driver and oil systems.

- **7.3.4.6 Gear test**

If an external gearbox is provided in the drive train it shall be tested with the machine unit during the mechanical running test.

- **7.3.4.7 Helium test**

Pressure containing parts, such as compressor casings and cylinders, shall be tested for gas leakage with helium at the maximum allowable working pressure. The test shall be conducted with the casing submerged in water. The water shall be at a higher temperature than the nil ductility transition temperature for the material of which the part is made. The maximum allowable working pressure shall be maintained for a minimum of 30 minutes, with no bubbles permitted. As an alternative, a nonsubmerged soap-bubble test or other approved method to check for gas leakage may be performed if approved by the purchaser. Ref. ASTM E-1003 *Standard Test Method for Hydrostatic Leak Testing*.

Note: A helium test should be specified when the molar mass of the gas handled is less than 12, or when the gas contains more than 0.1 mole percent hydrogen sulphide.

- **7.3.4.8 Sound-level test**

The sound-level test shall be performed in accordance with ISO 3744 or other agreed standard.

Note: A sound level test on the test stand is not representative of the sound level in the field due to differences in operating conditions and piping system.

- **7.3.4.9 Auxiliary-equipment test**

Auxiliary equipment such as oil systems, gears, and control systems shall be tested in the vendor's shop. Details of the auxiliary-equipment tests shall be developed jointly by the purchaser and the vendor.

- **7.3.4.10 Post-test inspection**

If specified, the compressor, the gear, and the driver shall be dismantled, inspected, and reassembled after satisfactory completion of the mechanical running test. The purchaser should specify whether the gas test required by 7.3.3.4.3 shall be performed before or after the post-test inspection.

- **7.3.4.11 Full-pressure/full-load/full-speed test**

The objectives and details of the full-pressure/full-load/full-speed test shall be developed jointly by the purchaser and the vendor. This test may be substituted for the mechanical running test.

- **7.3.4.12 Inspection of hub/shaft fit for hydraulically mounted couplings**

After the running tests, the shrink fit of hydraulically mounted couplings shall be inspected by comparing hub/shaft match marks to ensure that the coupling hub has not moved on the shaft during the tests.

- **7.3.4.13 Spare-parts test**

Spare parts such as couplings, gears, and seals shall be tested as specified.

Note: A mechanical test of the spare rotor set is mandated in 7.3.3.4.2

### 7.3.5 Test data

Immediately upon completion of each witnessed mechanical, performance, and optional tests, copies of the data logged shall be given to the witness.

The purchaser and the vendor shall mutually agree that the test data have met the acceptance criteria shown in the Test Specification.

- **7.3.6 Test report**

If specified, the vendor shall provide test reports within the timetable identified in Annex I.

## 7.4 Preparation for shipment

**7.4.1** Equipment shall be prepared for the type of shipment specified, including blocking of the rotor when necessary. Blocked rotors shall be identified by means of corrosion resistant tags attached with stainless steel wire. The preparation shall make the equipment suitable for 6 months of outdoor storage from the time of shipment, with no disassembly required before operation, except for inspection of bearings and seals. If storage for a longer period is contemplated, the purchaser should consult with the vendor regarding the recommended procedures to be followed.

**7.4.2** The vendor shall provide the purchaser with the instructions necessary to preserve the integrity of the storage preparation after the equipment arrives at the job site and before start-up, as described in Chapter 3 of API 686 *Recommended Practices for Machinery Installation and Installation Design*.

**7.4.3** The equipment shall be prepared for shipment after all testing and inspection have been completed and the equipment has been released by the purchaser. The preparation shall include the following:

- Except for machined surfaces, all exterior surfaces that may corrode during shipment, storage or in service, shall be given at least one coat of the manufacturer's standard paint. The paint shall not contain lead or chromates.  
Note: Austenitic stainless steels are typically not painted.
- Exterior machined surfaces except for corrosion-resistant material shall be coated with a rust preventive.
- The interior of the equipment shall be clean; free from scale, welding spatter and foreign objects; and sprayed or flushed with a rust preventive that can be removed with solvent. The rust preventive shall be applied through all openings while the rotor is rotated.
- Internal surfaces of bearing housings and carbon steel oil systems' components shall be coated with an oil-soluble rust preventive that is compatible with the lubricating oil.

Any paint exposed to lubricants must be oil resistant. When synthetic lubricants are used, special precautions must be taken to assure compatibility with the paint.

- Permanent internal coating must be compatible with process gases, cooling media, and lubricants.
- f) If specified, flanged openings shall be provided with metal closures at least 5 mm ( $\frac{3}{16}$  in) thick with elastomer gaskets and at least 4 full-diameter bolts. For studded openings, all nuts needed for the intended service shall be used to secure closures. Each opening shall be car sealed so that the protective cover cannot be removed without the seal being broken.

- g) Threaded openings shall be provided with steel caps or round-head steel plugs. In no case shall non-metallic (such as plastic) caps or plugs be used.  
 Note: These are shipping plugs; permanent plugs are covered in 5.3.11.
- h) Openings that have been beveled for welding shall be provided with closures designed to prevent entrance of moisture and foreign materials, and damage to the bevel.
- i) Lifting points and lifting lugs shall be clearly identified on the equipment or equipment package. The recommended lifting arrangement shall be as described in the installation manual.
- j) The equipment shall be identified with item and serial numbers. Material shipped separately shall be identified with securely affixed, corrosion-resistant metal tags indicating the item and serial number of the equipment for which it is intended. Crated equipment shall be shipped with duplicate packing lists, one inside and one on the outside of the shipping container.
- k) A spare rotor set, when purchased, shall be prepared for unheated indoor storage for a period of at least 3 years. It shall be treated with a rust preventive and shall be housed in a vapor-barrier envelope with a slow-release volatile-corrosion inhibitor. The rotor shall be crated for domestic or export shipment as specified. A purchaser-approved resilient material 3 mm ( $1/8$  in) thick [not tetrafluoroethylene (TFE) or polytetrafluoroethylene (PTFE)] shall be used between the rotor and the cradle at the support areas. Mark the probe target area barriers with the words "Probe Area—Do Not Cut". When specified, the rotor shall be prepared for vertical storage. It shall be supported from its coupling end with a fixture designed to support 1.5 times the rotor's weight without damaging the shaft. Instructions on the use of the fixture shall be included in the installation, operation and maintenance manuals.

Note: TFE and PTFE are not recommended as cradle support liners since they cold flow and impregnate into the surface.

- l) Critical shaft areas such as journals, end seal areas, probe target areas, and coupling fit areas shall be protected with a corrosion barrier followed by a separate barrier material to protect against incidental mechanical damage.
- m) Loose components shall be dipped in wax or placed in plastic bags and contained by cardboard boxes. Loose boxes are to be securely blocked in the shipping container.

**7.4.4** Auxiliary piping connections furnished on the purchased equipment shall be impression stamped or permanently tagged to agree with the vendor's connection table or general arrangement drawing. Service and connection designations shall be indicated.

**7.4.5** Bearing assemblies shall be fully protected from the entry of moisture and dirt. If volatile corrosion inhibitor crystals in bags are installed in large cavities to absorb moisture, the bags must be attached in an accessible area for ease of removal. Where applicable, bags shall be installed in wire cages attached to flanged covers, and bag locations shall be indicated by corrosion-resistant tags attached with stainless steel wire.

**7.4.6** One copy of the manufacturer's installation instructions shall be packed and shipped with the equipment.

**7.4.7** Connections on auxiliary piping, removed for shipment, shall be match-marked for ease of reassembly.

- **7.4.8** If specified, the fit-up and assembly of machine-mounted piping, intercoolers etc. shall be completed in the vendor's shop prior to shipment.
- **7.4.9** If specified, the vendor shall provide lifting tools suitable for lifting the equipment or equipment package.

Note: Lifting tools may include spreader bars, shackles and slings.

## 8 Vendor's data

### 8.1 General

**8.1.1** The information to be furnished by the vendor is specified in 8.2 and 8.3.

**8.1.2** The data shall be identified on transmittal (cover) letters, title pages and in title blocks or other prominent position on drawings, with the following information:

- a) The purchaser's/owner's corporate name.

- b) The job/project number.
  - c) The equipment item number and service name.
  - d) The inquiry or purchase order number.
  - e) Any other identification specified in the inquiry or purchase order.
  - f) The vendor's identifying proposal number, shop order number, serial number, or other reference required to completely identify return correspondence.
- **8.1.3** A coordination meeting shall be held, preferably at the vendor's plant, within 4-6 weeks after order commitment. Unless otherwise specified, the vendor shall prepare and distribute an agenda prior to this meeting, which as a minimum shall include a review of the following items:
    - a) The purchase order, scope of supply, unit responsibility, subvendor items and lines of communications.
    - b) The data sheets.
    - c) Applicable specifications and previously agreed exceptions.
    - d) Schedules for the transmittal of data, production and testing.
    - e) The quality assurance program and procedures.
    - f) Inspection, expediting and testing.
    - g) Schematics and bills of materials for auxiliary systems.
    - h) The physical orientation of the equipment, piping and auxiliary systems, including access for operation and maintenance.
    - i) Coupling selection and rating.
    - j) Thrust and journal bearing sizing, estimated loadings and specific configurations.
    - k) Seal operation and controls.
    - l) Rotor dynamic analyses (lateral, torsional and transient torsional, as required).
    - m) Equipment performance, alternate operating conditions, start-up, shutdown and any operating limitations.
    - n) Scope and details of any pulsation or vibration analysis.
    - o) Instrumentation and controls.
    - p) Identification of items requiring design reviews.
    - q) Inspection, related acceptance criteria, and testing.
    - r) Expediting.
    - s) Other technical items.

## 8.2 Proposals

### 8.2.1 General

The vendor shall forward the original proposal, with the specified number of copies, to the addressee specified in the inquiry documents. The proposal shall include, as a minimum, the data specified in 8.2.2 through 8.2.4, and a specific statement that the equipment and all its components and auxiliaries are in strict accordance with this standard. If the equipment or any of its components or auxiliaries is not in strict accordance, the vendor shall include a list that details and explains each deviation. The vendor shall provide sufficient detail to enable the purchaser to evaluate any proposed alternative designs. All correspondence shall be clearly identified in accordance with 8.1.2.

### 8.2.2 Drawings

**8.2.2.1** The drawings indicated on the Vendor Drawing and Data Requirements or (VDDR form see Annex I) shall be included in the proposal. As a minimum, the following shall be included:

- a) A general arrangement or outline drawing for each machine train or skid-mounted package, showing overall dimensions, maintenance clearance dimensions, overall weights, erection weights, and the largest maintenance weight for each item. The direction of rotation and the size and location of major purchaser connections shall also be indicated.
- b) Cross-sectional drawings showing the details of the proposed equipment.
- c) Schematics of all auxiliary systems including fuel, lube oil, control, and electrical systems. Bills of material shall be included.
- d) Sketches that show methods of lifting the assembled machine or machines, packages, and major components and auxiliaries. (This information may be included on the drawings specified in item a above.)

**8.2.2.2** If “typical” drawings, schematics and bills of material are used , they shall be marked up to show the weight and dimension data to reflect the actual equipment and scope proposed.

### 8.2.3 Technical data

The following data shall be included in the proposal.

- a) The purchaser’s data sheets with complete vendor’s information entered thereon and literature to fully describe details of the offering.
- b) The predicted noise data (5.1.19).
- c) The Vendor Drawing and Data Requirements form (see Annex I) indicating the schedule according to which the vendor agrees to transmit all the data specified.
- d) A schedule for shipment of the equipment, in weeks after receipt of an order.
- e) A list of major wearing components, showing any interchangeability with the owner’s existing machines.
- f) A list of spare parts recommended for start-up and normal maintenance purposes.
- g) A list of the special tools furnished for maintenance.
- h) A description of any special weather protection and winterization required for start-up, operation, and periods of idleness, under the site conditions specified on the data sheets. This description shall clearly indicate the protection to be furnished by the purchaser as well as that included in the vendor’s scope of supply.
- i) A complete tabulation of utility requirements, e.g. steam, water, electricity, air, gas, lube oil (including the quantity and supply pressure of the oil required, and the heat load to be removed by the oil), and the nameplate power rating and operating power requirements of auxiliary drivers. Approximate data shall be clearly indicated as such.
- j) A description of any optional or additional tests and inspection procedures for materials as required by 5.11.1.4.
- k) A description of any special requirements, whether specified in the purchaser’s inquiry or as outlined in 5.10.3.3.1, and 5.11.1.2.
- l) A list of machines, similar to the proposed machine(s), that have been installed and operating under conditions analogous to those specified in the inquiry.
- m) Any start-up, shutdown, or operating restrictions required to protect the integrity of the equipment.
- n) A list of any components that can be construed as being of alternative design, hence requiring purchaser’s acceptance (4.5).
- o) For constant speed units, the vendor shall outline the procedure that can be followed to reduce power consumption, in the event that excess pressure or flow is developed.
- p) Vendor shall list all required relief valves and clearly indicate those furnished by the vendor.
- q) For flooded screw compressors, the vendor shall state retention time, maximum and minimum liquid levels and capacity in the separator vessel.

### 8.2.4 Curves

The vendor shall provide complete performance curves to encompass the map of operations, with any limitations indicated thereon. For constant speed equipment refer to the operating point on the data sheet.

### 8.2.5 Optional tests

The vendor shall furnish an outline of the procedures to be used for each of the special or optional tests that have been specified by the purchaser or proposed by the vendor.

## 8.3 Contract data

### 8.3.1 General

**8.3.1.1** Contract data shall be furnished by the vendor in accordance with the agreed Vendor Drawing and Data Requirements (VDDR) form.

Note: Typical VDDR form in Annex I should be completed by the purchaser to match the specific inquiry requirements.

**8.3.1.2** Each drawing shall have a title block in the lower right-hand corner with the date of certification, identification data specified in 8.1.2, revision number and date and title. Similar information shall be provided on all other documents including subvendor items.

**8.3.1.3** The purchaser will promptly review the vendor's data upon receipt; however, this review shall not constitute permission to deviate from any requirements in the order unless specifically agreed upon in writing. After the data have been reviewed and accepted, the vendor shall furnish certified copies in the quantities specified.

**8.3.1.4** A complete list of vendor data shall be included with the first issue of major drawings. This list shall contain titles, drawing numbers, and a schedule for transmittal of each item listed. This list shall cross-reference data with respect to the VDDR form in Annex I.

### **8.3.2 Drawings and technical data**

The drawings and data furnished by the vendor shall contain sufficient information so that together with the manuals specified in 8.3.5, the purchaser can properly install, operate, and maintain the equipment covered by the purchase order. All contract drawings and data shall be clearly legible (8-point minimum font size even if reduced from a larger size drawing), shall cover the scope of the agreed VDDR form, and shall satisfy the applicable detailed descriptions in Annex I.

### **8.3.3 Progress reports**

The vendor shall submit progress reports to the purchaser at intervals specified.

Note: Refer to the description of item 41 in Annex I for content of these reports.

### **8.3.4 Parts lists and recommended spares**

**8.3.4.1** The vendor shall submit complete parts lists for all equipment and accessories supplied. These lists shall include part names, manufacturers' unique part numbers, materials of construction (identified by applicable international standards). Each part shall be completely identified and shown on appropriate cross-sectional, assembly-type cutaway or exploded-view isometric drawings. Interchangeable parts shall be identified as such. Parts that have been modified from standard dimensions or finish to satisfy specific performance requirements shall be uniquely identified by part number. Standard purchased items shall be identified by the original manufacturer's name and part number.

**8.3.4.2** The vendor shall indicate on each of these complete parts lists all those parts that are recommended as start-up or maintenance spares, and the recommended stocking quantities of each. These should include spare parts recommendations of subsuppliers that were not available for inclusion in the vendor's original proposal.

### **8.3.5 Installation, operation, maintenance, and technical data manuals**

#### **8.3.5.1 General**

The vendor shall provide sufficient written instructions and all necessary drawings to enable the purchaser to install, operate, and maintain all of the equipment covered by the purchase order. This information shall be compiled in a manual or manuals with a cover sheet showing the information listed in 8.1.2, an index sheet, and a complete list of the enclosed drawings by title and drawing number. The manual or manuals shall be prepared specifically for the equipment covered by the purchase order. "Typical" manuals are unacceptable.

#### **8.3.5.2 Installation manual**

All information required for the proper installation of the equipment shall be compiled in a manual that must be issued no later than the time of issue of final certified drawings. For this reason, it may be separate from the operating and maintenance instructions. This manual shall contain information on alignment and grouting procedures, normal and maximum utility requirements, centers of mass, rigging provisions and procedures, and all other installation data. All drawings and data specified in 8.2.2 and 8.2.3 that are pertinent to proper installation shall be included as part of this manual (see also description of line item 38 in Annex I).



### **8.3.5.3 Operating and maintenance manual**

A manual containing all required operating and maintenance instructions shall be supplied not later than 2 weeks after all specified tests have been successfully completed. In addition to covering operation at all specified process conditions, this manual shall also contain separate sections covering operation under any specified extreme environmental conditions (see also description of line item 39 in Annex I).

- **8.3.5.4 Technical data manual**

If specified, the vendor shall provide the purchaser with a technical data manual within 30 days of completion of shop testing. (See description of line item 45 in Annex I for minimum requirements of this manual.)



**ANNEX A—TYPICAL DATASHEETS**  
(INFORMATIVE)

.....

# ROTARY-TYPE POSITIVE- DISPLACEMENT COMPRESSOR DATA SHEET US CUSTOMARY UNITS

JOB NO. \_\_\_\_\_ ITEM NO. \_\_\_\_\_  
 PURCHASE ORDER NO. \_\_\_\_\_ DATE \_\_\_\_\_  
 REQUISITION NO. \_\_\_\_\_  
 INQUIRY NO. \_\_\_\_\_  
 PAGE 1 OF 9 BY \_\_\_\_\_

DRAWING UNITS:  SI  US CUSTOM  DUAL (4.3)

1 APPLICABLE TO: <input type="radio"/> PROPOSAL <input type="radio"/> PURCHASE <input type="radio"/> AS BUILT DATE _____ 2 FOR _____ 3 SITE _____ 4 SERVICE _____ 5 MANUFACTURER _____ MODEL _____ 6 NOTE: <input type="radio"/> INDICATES INFORMATION TO BE COMPLETED BY PURCHASER <input type="checkbox"/> BY MANUFACTURER	REVISION _____ UNIT _____ SERIAL NO. _____ NO. REQUIRED _____ DRIVER (6.1) _____
---	--

### OPERATING CONDITIONS

ALL DATA ON PER UNIT BASIS	NORMAL (3.33) (5.1.3)	MAXIMUM	OTHER CONDITIONS (5.1.4)			
			A	B	C	D
11 <input type="radio"/> CERTIFIED POINT (✓) (5.1.4)						
12 <input type="radio"/> GAS HANDLED (ALSO SEE PAGE 2)						
13 <input type="radio"/> Required Capacity MMSCFD/SCFM (14.7 PSIA & 60°F) (DRY) (3.46 & 3.60)						
14 <input type="radio"/> WEIGHT FLOW, lbs/hr (WET)(DRY)						
15 <b>INLET CONDITIONS:</b> <input type="radio"/> COMPRESSOR INLET FLANGE <input type="radio"/> CUSTOMER CONNECTION						
16 <input type="radio"/> PRESSURE (PSIA)						
17 <input type="radio"/> TEMPERATURE (°F)						
18 <input type="radio"/> RELATIVE HUMIDITY (%)						
19 <input type="radio"/> MOLECULAR WEIGHT (M)						
20 <input type="checkbox"/> Cp/Cv (K <sub>1</sub> ) OR (K <sub>AVG</sub> ) (5.1.15.4)						
21 <input type="checkbox"/> COMPRESSIBILITY (Z <sub>1</sub> ) OR (Z <sub>AVG</sub> ) (5.1.15.5)						
22 <input type="checkbox"/> INLET VOLUME FLOW (CFM) (3.19)						
23 <b>DISCHARGE CONDITIONS:</b> <input type="radio"/> COMPRESSOR DISCHARGE FLANGE <input type="radio"/> CUSTOMER CONNECTION						
24 <input type="radio"/> PRESSURE (PSIA)						
25 <input type="checkbox"/> TEMPERATURE (°F)						
26 <input type="checkbox"/> Cp/Cv (K <sub>2</sub> ) OR (K <sub>AVG</sub> )						
27 <input type="checkbox"/> COMPRESSIBILITY (Z <sub>2</sub> ) OR (Z <sub>AVG</sub> )						
28 <input type="checkbox"/> DEW POINT (°F)						
29 <input type="radio"/> OIL CARRYOVER (PPM-BY WT.)						
30 <input type="checkbox"/> BHP REQUIRED (ALL LOSSES INCL)						
31 <input type="checkbox"/> SPEED (RPM)						
32 <input type="checkbox"/> PRESSURE RATIO (R)						
33 <input type="checkbox"/> VOLUMETRIC EFFICIENCY (%)						
34 <input type="checkbox"/> SILENCER Δ P (PSI) (6.9.3)						
35 <input type="radio"/> SETTLE OUT PRESSURE (PSIA) (5.1.5.)						
36 <input type="checkbox"/> PERFORMANCE CURVE NO.						

37

38 **PROCESS CONTROL:** (6.4.2.1)

39 METHOD:  SLIDE VALVE \_\_\_\_\_

40  BYPASS FROM \_\_\_\_\_ TO \_\_\_\_\_

41  BYPASS:  MANUAL  AUTO

42  SPEED VARIATION FROM \_\_\_\_\_ TO \_\_\_\_\_

43  OTHER \_\_\_\_\_

44 SIGNAL:  SOURCE \_\_\_\_\_

45  TYPE \_\_\_\_\_

46  RANGE: FOR PNEUMATIC CONTROL \_\_\_\_\_ RPM @ \_\_\_\_\_ PSIG \_\_\_\_\_ RPM @ \_\_\_\_\_ PSIG \_\_\_\_\_

47  OTHER \_\_\_\_\_

48 **SERVICE:**  SPECIAL PURPOSE (3.58)  GENERAL PURPOSE (3.15)

49  CONTINUOUS  INTERMITTENT  STANDBY (3.62)  DRY SCREW (3.9)  FLOODED SCREW (3.12)

50 **REMARKS:** Unless otherwise noted, all pressures are GAGE pressures.

51 \_\_\_\_\_

52 \_\_\_\_\_

53 \_\_\_\_\_

54 \_\_\_\_\_

**ROTARY-TYPE POSITIVE-  
DISPLACEMENT COMPRESSOR  
DATA SHEET  
US CUSTOMARY UNITS**

JOB NO. \_\_\_\_\_ ITEM NO. \_\_\_\_\_  
 REVISION NO. \_\_\_\_\_ DATE \_\_\_\_\_  
 PAGE 2 OF 9 BY \_\_\_\_\_ ###

1	GAS ANALYSIS (5.1.15.4)		NOR- MAL	MAX- IMUM	OTHER CONDITIONS				REMARKS
	<input type="radio"/> MOL %	<input type="radio"/> _____			A	B	C	D	
3		M.W.							
4	AIR	28.966							
5	OXYGEN	32.000							
6	NITROGEN	28.016							
7	WATER VAPOR	18.016							
8	CARBON MONOXIDE	28.010							
9	CARBON DIOXIDE	44.010							
10	HYDROGEN SULFIDE	34.076							(5.11.1.10)
11	HYDROGEN	2.016							
12	METHANE	16.042							
13	ETHYLENE	28.052							
14	ETHANE	30.068							
15	PROPYLENE	42.078							
16	PROPANE	44.094							
17	I-BUTANE	58.120							
18	n-BUTANE	58.120							
19	I-PENTANE	72.146							
20	n-PENTANE	72.146							
21	HEXANE PLUS								
22									
23									
24	<input type="radio"/> CORROSIVE								(5.11.1.7)
25	<input type="radio"/> SOLID PARTICLE								(5.1.25)
26	<input type="radio"/> LIQUID PARTICLE								(5.1.25)
27	<input type="radio"/> NACE MATERIALS								(5.11.1.10)
28	TOTAL								
29	AVG. MOL. WT.								
30	<b>SITE DATA:</b>								
31	<b>LOCATION:</b> (5.1.18)								
32	<input type="radio"/> INDOOR	<input type="radio"/> HEATED	<input type="radio"/> UNDER ROOF						
33	<input type="radio"/> OUTDOOR	<input type="radio"/> UNHEATED	<input type="radio"/> PARTIAL SIDES						
34	<input type="radio"/> GRADE	<input type="radio"/> MEZZANINE	<input type="radio"/> _____						
35	<input type="radio"/> WINTERIZATION REQ'D.	<input type="radio"/> TROPICALIZATION REQ'D.							
36	<input type="radio"/> ELEVATION _____ FT.	<input type="radio"/> BAROMETER _____ (PSIA)							
37	<input type="radio"/> RANGE OF AMBIENT TEMPS.:	<input type="radio"/> DRY BULB	<input type="radio"/> WET BULB						
38	SITE RATED °F								
39	NORMAL °F								
40	MAXIMUM °F								
41	MINIMUM °F								
42	<b>ELECTRICAL AREA CLASSIFICATION:(5.1.18)</b>								
43	<input type="radio"/> AREA: CL. _____ GR. _____ DIV. _____								
44	<b>UNUSUAL CONDITIONS:</b>	<input type="radio"/> DUST	<input type="radio"/> FUMES						
45	<input type="radio"/> OTHER _____								
46	_____								
47	_____								
48	_____								
49	_____								
50	<input type="radio"/> VENDOR HAVING UNIT RESPONSIBILITY: (3.65) _____								
51	_____								
52	_____								
53	<b>REMARKS:</b> _____								
54	_____								
55	_____								

**NOISE SPECIFICATIONS:** (5.1.19)

APPLICABLE TO MACHINE  
SEE SPECIFICATION \_\_\_\_\_

APPLICABLE TO NEIGHBORHOOD  
SEE SPECIFICATION \_\_\_\_\_

ACOUSTIC HOUSING: (5.1.20.1)  YES  NO

SOUND LEVEL \_\_\_\_\_ dB @ \_\_\_\_\_ FT. \_\_\_\_\_

dB RE: **20 MICRO PASCAL**

**APPLICABLE SPECIFICATIONS:**

API 619 POSITIVE DISPLACEMENT ROTARY COMPRESSORS

ACOUSTIC \_\_\_\_\_

MOTOR \_\_\_\_\_

---

**PAINTING:**

MANUFACTURER'S STD.

OTHER \_\_\_\_\_

---

**SHIPMENT:** (7.4.1)

DOMESTIC  EXPORT  EXPORT BOXING REQ'D

LONG TERM STORAGE FOR \_\_\_\_\_ MONTHS

**ROTARY-TYPE POSITIVE-  
DISPLACEMENT COMPRESSOR  
DATA SHEET  
US CUSTOMARY UNITS**

JOB NO. \_\_\_\_\_ ITEM NO. \_\_\_\_\_  
 REVISION NO. \_\_\_\_\_ DATE \_\_\_\_\_  
 PAGE 3 OF 9 BY \_\_\_\_\_

<p><input type="checkbox"/> <b>SPEEDS:</b></p> <p>2 MAX. CONT. (3.26) _____ RPM TRIP (3.64) _____ RPM</p> <p>3 MAX. TIP SPEEDS: _____ FPS @ MAX. OPER. SPEED</p> <p>4 MIN. ALLOW (3.30) _____ RPM</p> <p>5 <input type="checkbox"/> LATERAL CRITICAL SPEEDS: (5.7.1.4)</p> <p>6 FIRST CRITICAL _____ RPM</p> <p>7 DAMPED _____ UNDAMPED _____</p> <p>8 MODE SHAPE _____</p> <p>9 LATERAL CRITICAL SPEED - BASIS:</p> <p>10 <input type="radio"/> DAMPED UNBALANCE RESPONSE ANALYSIS</p> <p>11 <input type="checkbox"/> OTHER TYPE ANALYSIS: _____ (SPECIFY)</p> <p>12 <input type="checkbox"/> <b>POCKET PASSING FREQUENCY:</b> _____ Hz</p> <p>13 <input type="checkbox"/> <b>TORSIONAL CRITICAL SPEEDS:</b> (5.7.2)</p> <p>14 FIRST CRITICAL _____ RPM</p> <p>15 SECOND CRITICAL _____ RPM</p> <p>16 <input type="checkbox"/> <b>VIBRATION:</b> (5.7.3.6)</p> <p>17 HOUSING _____ IPS RMS</p> <p>18 SHAFT _____</p> <p>19 <input type="checkbox"/> <b>ROTATION, LOOK AT COMPRESSOR DRIVEN END:</b> <input type="checkbox"/> CW <input type="checkbox"/> CCW</p> <p>20 <input type="checkbox"/> <b>CASING:</b></p> <p>21 MODEL _____</p> <p>22 CASING SPLIT _____</p> <p>23 MATERIAL _____ <input type="radio"/> CLADDING (5.2.10)</p> <p>24 OPERATION: <input type="radio"/> DRY <input type="radio"/> FLOODED, w/ _____ LIQUID</p> <p>25 THICKNESS (IN.) _____ CORR. ALLOW (IN.) _____</p> <p>26 MAX. ALLOWABLE WORK PRESS. (3.25) _____ PSIG</p> <p>27 RELIEF VALVE SETTING _____ PSIG</p> <p>28 MARGIN FOR ACCUMULATION _____ PSIG</p> <p>29 <b>LEAK TEST GAS:</b> _____ <b>PRESS. (PSIG)</b> _____ (7.3.3.4.3.1)</p> <p>30 TEST PRESS. (PSIG) HE (7.3.4.6) _____ HYDRO (7.3.2) _____</p> <p>31 MAX. ALLOW. TEMP. _____ °F MIN. OPER. TEMP. _____ °F</p> <p>32 COOLING JACKET <input type="checkbox"/> YES <input type="checkbox"/> NO</p> <p>33 <input type="checkbox"/> <b>ROTORS:</b> (5.5.1)</p> <p>34 DIAMETER (IN.) <b>MALE:</b> _____ <b>FEMALE:</b> _____</p> <p>35 <b>NO. LOBES: MALE:</b> _____ <b>FEMALE:</b> _____</p> <p>36 TYPE: _____</p> <p>37 TYPE FABRICATION _____</p> <p>38 MATERIAL _____</p> <p>39 MAX. YIELD STRENGTH (PSI) _____</p> <p>40 BRINELL HARDNESS. MAX. _____ MIN. _____</p> <p>41 ROTOR LENGTH TO DIAMETER RATIO (L/D) <b>M:</b> _____</p> <p>42 ROTOR CLEARANCE (IN.) _____</p> <p>43 <b>INTERNALLY COOLED</b> <input type="checkbox"/> YES <input type="checkbox"/> NO</p>	<p><input type="checkbox"/> <b>SHAFT:</b> (5.5.1.2)</p> <p>MATERIAL _____</p> <p>DIA @ ROTORS (IN.) _____ DIA @ COUPLING (IN.) _____</p> <p>SHAFT END. <input type="checkbox"/> TAPERED <input type="checkbox"/> CYLINDRICAL (5.5.1.5 &amp; 5.5.1.6)</p> <p><b>SHAFT SLEEVES:</b></p> <p><input type="radio"/> AT SHAFT SEALS _____ <input type="checkbox"/> MATL. _____</p> <p><input type="checkbox"/> <b>TIMING GEARS:</b> (5.5.2)</p> <p>PITCH LINE DIAMETER (IN.) <b>MALE:</b> _____ <b>FEMALE:</b> _____</p> <p>MATERIAL _____</p> <p><input type="checkbox"/> <b>SHAFT SEALS:</b> (5.6)</p> <p><input type="radio"/> SEAL SYSTEM TYPE (5.6.1.7)</p> <p><input type="checkbox"/> OIL LEAKAGE (GAL/DAY/SEAL) _____</p> <p><input type="radio"/> TYPE BUFFER GAS (5.6.2.2) _____</p> <p><input type="checkbox"/> BUFFER GAS FLOW (PER SEAL)</p> <p>NORMAL: _____ #/MIN. @ _____ PSIG</p> <p>MAX.: _____ #/MIN. @ _____ PSIG</p> <p><input type="checkbox"/> <b>BEARING HOUSING:</b> (5.9)</p> <p>TYPE (SEPARATE, INTEGRAL) _____ SPLIT _____</p> <p>MATERIAL _____</p> <p><input type="checkbox"/> <b>HYDRODYNAMIC RADIAL BEARINGS:</b> (IDENTIFY HIGHEST LOADED BEARING)</p> <p>(5.8) TYPE _____ SPAN (IN) _____</p> <p>AREA (IN.<sup>2</sup>) _____ LOADING (PSI): ACT. _____ ALLOW. _____</p> <p>NO. PADS _____ ROTOR ON _____ OR BETWEEN _____ PADS</p> <p>PAD MATERIAL _____</p> <p>TYPE BABBITT _____ THICKNESS _____ (IN.)</p> <p><input type="radio"/> TEMP SENSORS (5.8.1.5)</p> <p><input type="radio"/> TC <input type="radio"/> RTD TYPE _____</p> <p>NO PER BRG _____</p> <p><input type="checkbox"/> <b>ROLLING ELEMENT RADIAL BEARING (5.8.2)</b></p> <p><b>TYPE:</b> _____ <b>Ndm:</b> _____</p> <p><b>ENERGY DENSITY:</b> _____</p> <p><input type="checkbox"/> <b>HYDRODYNAMIC THRUST BEARING:</b> (IDENTIFY HIGHEST LOADED BEARING)</p> <p>(5.8) TYPE _____</p> <p>MFR. _____ AREA (IN.<sup>2</sup>) _____</p> <p>LOADING (PSI): _____ ACT. _____ ALLOW. _____</p> <p>NUMBER OF PADS _____</p> <p>PAD MATERIAL _____</p> <p>TYPE BABBITT _____ THICKNESS _____ (IN.)</p> <p><input type="radio"/> TEMP SENSORS (5.8.1.5)</p> <p><input type="radio"/> TC <input type="radio"/> RTD TYPE _____</p> <p>NO PER BRG _____ <input type="checkbox"/> ACTIVE <input type="checkbox"/> INACTIVE</p> <p><input type="checkbox"/> <b>ROLLING ELEMENT THRUST BEARING (5.8.2)</b></p> <p><b>TYPE:</b> _____ <b>Ndm:</b> _____</p> <p><b>ENERGY DENSITY:</b> _____</p>
<p>46 <b>REMARKS:</b> _____</p> <p>47 _____</p> <p>48 _____</p> <p>49 _____</p> <p>50 _____</p> <p>51 _____</p> <p>52 _____</p>	





# ROTARY-TYPE POSITIVE- DISPLACEMENT COMPRESSOR DATA SHEET US CUSTOMARY UNITS

JOB NO. \_\_\_\_\_ ITEM NO. \_\_\_\_\_  
 REVISION NO. \_\_\_\_\_ DATE \_\_\_\_\_  
 PAGE 5 OF 9 BY \_\_\_\_\_

1 **UTILITY CONDITIONS: (ALL UNITS ARE "GAUGE")**

2 STEAM	DRIVERS	HEATING			
3 INLET	MIN. _____ PSIG _____ °F	_____ PSIG _____ °F	_____ PSIG _____ °F	_____ PSIG _____ °F	_____ PSIG _____ °F
4	NORM _____ PSIG _____ °F	_____ PSIG _____ °F	_____ PSIG _____ °F	_____ PSIG _____ °F	_____ PSIG _____ °F
5	MAX. _____ PSIG _____ °F	_____ PSIG _____ °F	_____ PSIG _____ °F	_____ PSIG _____ °F	_____ PSIG _____ °F
6 EXHAUST	MIN. _____ PSIG _____ °F	_____ PSIG _____ °F	_____ PSIG _____ °F	_____ PSIG _____ °F	_____ PSIG _____ °F
7	NORM _____ PSIG _____ °F	_____ PSIG _____ °F	_____ PSIG _____ °F	_____ PSIG _____ °F	_____ PSIG _____ °F
8	MAX. _____ PSIG _____ °F	_____ PSIG _____ °F	_____ PSIG _____ °F	_____ PSIG _____ °F	_____ PSIG _____ °F

9 **ELECTRICITY:**

	DRIVERS	HEATING	CONTROL	SHUT- DOWN
10	_____	_____	_____	_____
11 VOLTAGE	_____	_____	_____	_____
12 HERTZ	_____	_____	_____	_____
13 PHASE	_____	_____	_____	_____

14 **COOLING WATER**

15 TEMP. INLET \_\_\_\_\_ °F MAX. RETURN \_\_\_\_\_ °F

16 PRESS. NORM \_\_\_\_\_ PSIG DESIGN \_\_\_\_\_ PSIG

17 MIN. RETURN \_\_\_\_\_ PSIG MAX. ALLOW Δ P \_\_\_\_\_ PSI

18 WATER SOURCE \_\_\_\_\_

19 **INSTRUMENT AIR:**

20 MAX PRESS \_\_\_\_\_ PSIG MIN. \_\_\_\_\_ PSIG

21  **TOTAL UTILITY CONSUMPTION:**

22 COOLING WATER \_\_\_\_\_ GPM

23 STEAM, NORMAL \_\_\_\_\_ lbs/HR

24 STEAM, MAX \_\_\_\_\_ lbs/HR

25 INSTRUMENT AIR \_\_\_\_\_ SCFM

26 HP (DRIVER) \_\_\_\_\_ HP

**WEIGHTS (LBS):**

COMPR. \_\_\_\_\_ GEAR \_\_\_\_\_ DRIVER \_\_\_\_\_ BASE \_\_\_\_\_

ROTORS: COMPR. \_\_\_\_\_ DRIVER \_\_\_\_\_ GEAR \_\_\_\_\_

COMPR. UPPER CASE \_\_\_\_\_

L.O. CONSOLE \_\_\_\_\_ S.O. CONSOLE \_\_\_\_\_

MAX. FOR MAINTENANCE (IDENTIFY) \_\_\_\_\_

TOTAL SHIPPING WEIGHT \_\_\_\_\_

**SPACE REQUIREMENTS (FEET & INCHES):**

COMPLETE UNIT L \_\_\_\_\_ W \_\_\_\_\_ H \_\_\_\_\_

L.O. CONSOLE L \_\_\_\_\_ W \_\_\_\_\_ H \_\_\_\_\_

S.O. CONSOLE: L \_\_\_\_\_ W \_\_\_\_\_ H \_\_\_\_\_

**MISCELLANEOUS:**

RECOMMEND STRAIGHT RUN OF PIPE DIA. BEFORE SUCTION

VENDOR'S REVIEW & COMMENTS ON PURCHASER'S PIPING & FOUNDATION (5.1.16)

VENDOR REPRESENTATIVE OBSERVATION AT THE SITE (5.1.17)

OPTICAL ALIGNMENT FLATS REQUIRED ON COMPRESSOR, GEAR & DRIVER

LATERAL ANALYSIS & REPORT REQUIRED (5.7.1.4)

TORSIONAL ANALYSIS REPORT REQUIRED (5.7.2.1)

CASING MOUNTED TORSIONAL SHAFT VIBRATION PICKUP

COORDINATION MEETING (8.1.3)

29

30 **SHOP INSPECTION AND TESTS: (7.1)**

	REQD	WITNESS	OBSERVE
31 SHOP INSPECTION (7.1.5)	<input type="checkbox"/>	<input type="checkbox"/>	<input type="checkbox"/>
32 HYDROSTATIC (7.3.2)	<input type="checkbox"/>	<input type="checkbox"/>	<input type="checkbox"/>
33 HELIUM LEAK (7.3.4.6)	<input type="checkbox"/>	<input type="checkbox"/>	<input type="checkbox"/>
34 MECHANICAL RUN (7.3.3)	<input type="checkbox"/>	<input type="checkbox"/>	<input type="checkbox"/>
35 MECHANICAL RUN SPARE ROTORS (7.3.3.4.2)	<input type="checkbox"/>	<input type="checkbox"/>	<input type="checkbox"/>
36 CASING LEAK TEST (7.3.3.4.3)	<input type="checkbox"/>	<input type="checkbox"/>	<input type="checkbox"/>
37 PERFORMANCE TEST (GAS) (AIR) (7.3.4.1)	<input type="checkbox"/>	<input type="checkbox"/>	<input type="checkbox"/>
38 COMPLETE UNIT TEST (7.3.4.2)	<input type="checkbox"/>	<input type="checkbox"/>	<input type="checkbox"/>
39 USE SHOP LUBE & SEAL SYSTEM	<input type="checkbox"/>	<input type="checkbox"/>	<input type="checkbox"/>
40 USE JOB LUBE & SEAL SYSTEM (7.3.4.8)	<input type="checkbox"/>	<input type="checkbox"/>	<input type="checkbox"/>
41 USE SHOP VIBRATION PROBES, ETC.	<input type="checkbox"/>	<input type="checkbox"/>	<input type="checkbox"/>
42 USE JOB VIB. & AXIAL DISP. PROBES,	<input type="checkbox"/>	<input type="checkbox"/>	<input type="checkbox"/>
43 USE SEISMIC TRANSDUCERS & MONITORS	<input type="checkbox"/>	<input type="checkbox"/>	<input type="checkbox"/>
44 USE JOB MONITORING EQUIPMENT	<input type="checkbox"/>	<input type="checkbox"/>	<input type="checkbox"/>
45 PRESSURE COMP. TO FULL OPER. PRESSURE	<input type="checkbox"/>	<input type="checkbox"/>	<input type="checkbox"/>
46 DISASSEMBLE-REASSEMBLE COMP.	<input type="checkbox"/>	<input type="checkbox"/>	<input type="checkbox"/>
47 AFTER TEST (7.3.4.9)	<input type="checkbox"/>	<input type="checkbox"/>	<input type="checkbox"/>
48 SOUND-LEVEL TEST (7.3.4.7)	<input type="checkbox"/>	<input type="checkbox"/>	<input type="checkbox"/>
49 TANDEM (7.3.4.4)	<input type="checkbox"/>	<input type="checkbox"/>	<input type="checkbox"/>
50 AUX. EQUIPMENT (7.3.4.8)	<input type="checkbox"/>	<input type="checkbox"/>	<input type="checkbox"/>
51 FULL-LOAD TEST (7.3.4.10)	<input type="checkbox"/>	<input type="checkbox"/>	<input type="checkbox"/>
52 RESIDUAL UNBALANCE CHECK (5.7.3.5)	<input type="checkbox"/>	<input type="checkbox"/>	<input type="checkbox"/>
53			

**INLET & DISCHARGE DEVICES:**

HIGH EFFICIENCY INLET SEPARATOR REQUIRED (6.8.2)

INLET AIR FILTER DP INDICATION TYPE (6.7.3) \_\_\_\_\_

PULSATION SUPPRESSORS FURNISHED BY \_\_\_\_\_

SPARE PARTS TO BE SUPPLIED (8.2.3F)

ROTOR ASSEMBLY

SEALS  GASKETS, O-RINGS

START-UP/COMMISSIONING

2 YEARS SUPPLY

OTHER: \_\_\_\_\_

**REMARKS:**

\_\_\_\_\_

\_\_\_\_\_

\_\_\_\_\_

\_\_\_\_\_

\_\_\_\_\_

\_\_\_\_\_

\_\_\_\_\_

\_\_\_\_\_

\_\_\_\_\_

\_\_\_\_\_

# ROTARY-TYPE POSITIVE- DISPLACEMENT COMPRESSOR DATA SHEET US CUSTOMARY UNITS

JOB NO. \_\_\_\_\_ ITEM NO. \_\_\_\_\_  
 REVISION NO. \_\_\_\_\_ DATE \_\_\_\_\_  
 PAGE 6 OF 9 BY \_\_\_\_\_

VENDOR MUST FURNISH ALL PERTINENT DATA FOR THIS SPECIFICATION SHEET BEFORE RETURNING.  
 ITEM NO. \_\_\_\_\_ SERVICE \_\_\_\_\_ JOB NO. \_\_\_\_\_  
 MANUFACTURER \_\_\_\_\_

1 **REFERENCE SPECIFICATIONS: (6.4.1.2)**  
 2 API 614  YES  NO  
 3 \_\_\_\_\_  
 4 \_\_\_\_\_  
 5 \_\_\_\_\_  
 6 \_\_\_\_\_  
 7 \_\_\_\_\_

**APPLICABLE SPECIFICATIONS:**  IEC \_\_\_\_\_  NEMA \_\_\_\_\_  
**AREA CLASSIFICATION:**  
 AREA: CL. \_\_\_\_\_ GR. \_\_\_\_\_ DIV. \_\_\_\_\_  NON-HAZARDOUS  
**MOTOR CONTROL & INSTRUMENT VOLTAGE:**  
 VOLTS \_\_\_\_\_ PHASE \_\_\_\_\_ CYCLES \_\_\_\_\_  
**ALARM & SHUTDOWN VOLTAGE:**  
 VOLTS \_\_\_\_\_ PHASE \_\_\_\_\_ CYCLES OR \_\_\_\_\_ DC

8 **LOCAL CONTROL PANEL: (6.4.3)**  
 9 FURNISHED BY:  VENDOR  PURCHASER  OTHERS \_\_\_\_\_  
 10  FREE STANDING  WEATHERPROOF  TOTALLY ENCLOSED  EXTRA CUTOUTS  
 11  VIBRATION ISOLATORS  STRIP HEATERS  PURGE CONNECTIONS  
 12 ANNUNCIATOR: FURNISHED BY:  VENDOR  PURCHASER  OTHERS \_\_\_\_\_  
 13 ANNUNCIATOR LOCATED ON  LOCAL PANEL  MAIN CONTROL BOARD  
 14  CUSTOMER CONNECTIONS BROUGHT OUT TO TERMINAL BOXES BY VENDOR

15 **INSTRUMENT SUPPLIERS:**

16 <input type="radio"/> PRESSURE GAUGES:	MFR. _____	SIZE & TYPE: _____
17 <input type="radio"/> TEMPERATURE GAUGES:	MFR. _____	SIZE & TYPE: _____
18 <input type="radio"/> LEVEL GAUGES:	MFR. _____	SIZE & TYPE: _____
19 <input type="radio"/> DIFF. PRESSURE GAUGES:	MFR. _____	SIZE & TYPE: _____
20 <input type="radio"/> PRESSURE SWITCHES:	MFR. _____	SIZE & TYPE: _____
21 <input type="radio"/> DIFF. PRESSURE SWITCHES:	MFR. _____	SIZE & TYPE: _____
22 <input type="radio"/> TEMPERATURE SWITCHES:	MFR. _____	SIZE & TYPE: _____
23 <input type="radio"/> LEVEL SWITCHES:	MFR. _____	SIZE & TYPE: _____
24 <input type="radio"/> CONTROL VALVES:	MFR. _____	SIZE & TYPE: _____
25 <input type="radio"/> PRESSURE RELIEF VALVES: (6.4.4.5)	MFR. _____	SIZE & TYPE: _____
26 <input type="radio"/> THERMAL RELIEF VALVES: (6.4.4.5.4)	MFR. _____	SIZE & TYPE: _____
27 <input type="radio"/> FLOW INDICATORS: (6.4.4.8)	MFR. _____	SIZE & TYPE: _____
28 <input type="radio"/> GAS FLOW INDICATOR:	MFR. _____	SIZE & TYPE: _____
29 <input type="radio"/> VIBRATION EQUIPMENT:	MFR. _____	SIZE & TYPE: _____
30 <input type="radio"/> TACHOMETER: (6.4.4.2)	MFR. _____	RANGE & TYPE: _____
31 <input type="radio"/> SOLENOID VALVES	MFR. _____	SIZE & TYPE: _____
32 <input type="radio"/> ANNUNCIATOR: (6.4.5.9)	MFR. _____	MODEL & NO. POINTS _____
33 <input type="radio"/> DEPRESSURIZATION VALVE (6.4.4.6)	MFR. _____	SIZE & TYPE: _____
34 _____	MFR. _____	SIZE & TYPE: _____

35 NOTE:  SUPPLIED BY VENDOR  SUPPLIED BY PURCHASER

PRESSURE GAUGE REQUIREMENTS			LOCAL			FUNCTION			LOCAL		
FUNCTION	LOCALLY MOUNTED (3.21)	LOCAL PANEL (3.38)	FUNCTION	LOCALLY MOUNTED (3.21)	LOCAL PANEL (3.38)	FUNCTION	LOCALLY MOUNTED (3.21)	LOCAL PANEL (3.38)	FUNCTION	LOCALLY MOUNTED (3.21)	LOCAL PANEL (3.38)
38 LUBE OIL PUMP DISCHARGE	<input type="checkbox"/> <input type="radio"/>	<input type="checkbox"/> <input type="radio"/>	38 GOV. CONTROL OIL	<input type="checkbox"/> <input type="radio"/>	<input type="checkbox"/> <input type="radio"/>	38 GOV. CONTROL OIL	<input type="checkbox"/> <input type="radio"/>	<input type="checkbox"/> <input type="radio"/>	38 GOV. CONTROL OIL Δ P	<input type="checkbox"/> <input type="radio"/>	<input type="checkbox"/> <input type="radio"/>
39 LUBE OIL FILTER Δ P	<input type="checkbox"/> <input type="radio"/>	<input type="checkbox"/> <input type="radio"/>	39 GOV. CONTROL OIL Δ P	<input type="checkbox"/> <input type="radio"/>	<input type="checkbox"/> <input type="radio"/>	39 MAIN STEAM IN	<input type="checkbox"/> <input type="radio"/>	<input type="checkbox"/> <input type="radio"/>	39 1ST STAGE STEAM	<input type="checkbox"/> <input type="radio"/>	<input type="checkbox"/> <input type="radio"/>
40 LUBE OIL SUPPLY	<input type="checkbox"/> <input type="radio"/>	<input type="checkbox"/> <input type="radio"/>	40 MAIN STEAM IN	<input type="checkbox"/> <input type="radio"/>	<input type="checkbox"/> <input type="radio"/>	40 STEAM CHEST	<input type="checkbox"/> <input type="radio"/>	<input type="checkbox"/> <input type="radio"/>	40 EXHAUST STEAM	<input type="checkbox"/> <input type="radio"/>	<input type="checkbox"/> <input type="radio"/>
41 SEAL OIL PUMP DISCHARGE	<input type="checkbox"/> <input type="radio"/>	<input type="checkbox"/> <input type="radio"/>	41 1ST STAGE STEAM	<input type="checkbox"/> <input type="radio"/>	<input type="checkbox"/> <input type="radio"/>	41 STEAM CHEST	<input type="checkbox"/> <input type="radio"/>	<input type="checkbox"/> <input type="radio"/>	41 EXHAUST STEAM	<input type="checkbox"/> <input type="radio"/>	<input type="checkbox"/> <input type="radio"/>
42 SEAL OIL FILTER Δ P	<input type="checkbox"/> <input type="radio"/>	<input type="checkbox"/> <input type="radio"/>	42 STEAM CHEST	<input type="checkbox"/> <input type="radio"/>	<input type="checkbox"/> <input type="radio"/>	42 EXHAUST STEAM	<input type="checkbox"/> <input type="radio"/>	<input type="checkbox"/> <input type="radio"/>	42 EXTRACTION STEAM	<input type="checkbox"/> <input type="radio"/>	<input type="checkbox"/> <input type="radio"/>
43 SEAL OIL SUPPLY (EACH LEVEL)	<input type="checkbox"/> <input type="radio"/>	<input type="checkbox"/> <input type="radio"/>	43 EXHAUST STEAM	<input type="checkbox"/> <input type="radio"/>	<input type="checkbox"/> <input type="radio"/>	43 EXTRACTION STEAM	<input type="checkbox"/> <input type="radio"/>	<input type="checkbox"/> <input type="radio"/>	43 STEAM EJECTOR	<input type="checkbox"/> <input type="radio"/>	<input type="checkbox"/> <input type="radio"/>
44 SEAL OIL DIFFERENTIAL	<input type="checkbox"/> <input type="radio"/>	<input type="checkbox"/> <input type="radio"/>	44 EXTRACTION STEAM	<input type="checkbox"/> <input type="radio"/>	<input type="checkbox"/> <input type="radio"/>	44 STEAM EJECTOR	<input type="checkbox"/> <input type="radio"/>	<input type="checkbox"/> <input type="radio"/>	44 COMPRESSOR SUCTION	<input type="checkbox"/> <input type="radio"/>	<input type="checkbox"/> <input type="radio"/>
45 REFERENCE GAS	<input type="checkbox"/> <input type="radio"/>	<input type="checkbox"/> <input type="radio"/>	45 STEAM EJECTOR	<input type="checkbox"/> <input type="radio"/>	<input type="checkbox"/> <input type="radio"/>	45 COMPRESSOR SUCTION	<input type="checkbox"/> <input type="radio"/>	<input type="checkbox"/> <input type="radio"/>	45 COMPRESSOR DISCHARGE	<input type="checkbox"/> <input type="radio"/>	<input type="checkbox"/> <input type="radio"/>
46 BALANCE LINE	<input type="checkbox"/> <input type="radio"/>	<input type="checkbox"/> <input type="radio"/>	46 COMPRESSOR SUCTION	<input type="checkbox"/> <input type="radio"/>	<input type="checkbox"/> <input type="radio"/>	46 COMPRESSOR DISCHARGE	<input type="checkbox"/> <input type="radio"/>	<input type="checkbox"/> <input type="radio"/>	_____	<input type="checkbox"/> <input type="radio"/>	<input type="checkbox"/> <input type="radio"/>
47 SEAL EDUCTOR	<input type="checkbox"/> <input type="radio"/>	<input type="checkbox"/> <input type="radio"/>	47 COMPRESSOR DISCHARGE	<input type="checkbox"/> <input type="radio"/>	<input type="checkbox"/> <input type="radio"/>	_____	<input type="checkbox"/> <input type="radio"/>	<input type="checkbox"/> <input type="radio"/>	_____	<input type="checkbox"/> <input type="radio"/>	<input type="checkbox"/> <input type="radio"/>
48 BUFFER SEAL	<input type="checkbox"/> <input type="radio"/>	<input type="checkbox"/> <input type="radio"/>	_____	<input type="checkbox"/> <input type="radio"/>	<input type="checkbox"/> <input type="radio"/>	_____	<input type="checkbox"/> <input type="radio"/>	<input type="checkbox"/> <input type="radio"/>	_____	<input type="checkbox"/> <input type="radio"/>	<input type="checkbox"/> <input type="radio"/>
49 OIL/GAS COALESCING FILTER Δ P	<input type="checkbox"/> <input type="radio"/>	<input type="checkbox"/> <input type="radio"/>	_____	<input type="checkbox"/> <input type="radio"/>	<input type="checkbox"/> <input type="radio"/>	_____	<input type="checkbox"/> <input type="radio"/>	<input type="checkbox"/> <input type="radio"/>	_____	<input type="checkbox"/> <input type="radio"/>	<input type="checkbox"/> <input type="radio"/>

# ROTARY-TYPE POSITIVE- DISPLACEMENT COMPRESSOR DATA SHEET US CUSTOMARY UNITS

JOB NO. \_\_\_\_\_ ITEM NO. \_\_\_\_\_  
 REVISION NO. \_\_\_\_\_ DATE \_\_\_\_\_  
 PAGE 7 OF 9 BY \_\_\_\_\_

VENDOR MUST FURNISH ALL PERTINENT DATA FOR THIS SPECIFICATION SHEET BEFORE RETURNING.  
 ITEM NO. \_\_\_\_\_ SERVICE \_\_\_\_\_ JOB NO. \_\_\_\_\_  
 MANUFACTURER \_\_\_\_\_

1	TEMPERATURE GAUGE REQUIREMENTS:			
2		LOCALLY MOUNTED (3.21)	LOCAL PANEL (3.28)	
3	<b>FUNCTION</b>			<b>FUNCTION</b>
4	LUBE OIL DISCHARGE FROM EA.	<input type="checkbox"/> <input type="checkbox"/>	<input type="checkbox"/> <input type="checkbox"/>	COOLER OIL INLET & OUTLET
5	COMPR. JOURNAL BEARING	<input type="checkbox"/> <input type="checkbox"/>	<input type="checkbox"/> <input type="checkbox"/>	SEAL OIL OUTLET
6	DRIVER JOURNAL BEARING	<input type="checkbox"/> <input type="checkbox"/>	<input type="checkbox"/> <input type="checkbox"/>	COMPRESSOR SUCTION
7	GEAR JOURNAL BEARING	<input type="checkbox"/> <input type="checkbox"/>	<input type="checkbox"/> <input type="checkbox"/>	COMPRESSOR DISCHARGE
8	COMPRESSOR THRUST BEARING	<input type="checkbox"/> <input type="checkbox"/>	<input type="checkbox"/> <input type="checkbox"/>	LUBE OIL RESERVOIR
9	DRIVER THRUST BEARING	<input type="checkbox"/> <input type="checkbox"/>	<input type="checkbox"/> <input type="checkbox"/>	<b>LUBE OIL SUPPLY</b>
10	GEAR THRUST BEARING	<input type="checkbox"/> <input type="checkbox"/>	<input type="checkbox"/> <input type="checkbox"/>	

- 11 **MISCELLANEOUS INSTRUMENTATION:**
- 12   DRIVER START/STOP  LOCAL PANEL  SEPARATE PANEL  MAIN BOARD
- 13   SIGHT FLOW INDICATORS, EACH JOURNAL & THRUST BEARING & EACH COUPLING OIL RETURN LINE
- 14   SIGHT FLOW INDICATORS, EACH SEAL OIL RETURN LINE
- 15   LEVEL GAUGES, LUBE AND/OR SEAL OIL RESERVOIR, S.O. DRAIN TRAPS & S.O. OVERHEAD TANK
- 16   VIBRATION AND SHAFT POSITION PROBES & PROXIMITORS
- 17   VIBRATION AND SHAFT POSITION READOUT EQUIPMENT
- 18   VIBRATION READOUT LOCATED ON:  LOCAL PANEL  SEPARATE PANEL  MAIN BOARD
- 19   TURBINE SPEED PICKUP DEVICES
- 20   TURBINE SPEED INDICATORS
- 21   TURBINE SPEED INDICATORS LOCATED ON:  LOCAL PANEL  MAIN BOARD
- 22   REMOTE HAND SPEED CHANGER - MOUNTED ON LOCAL PANEL
- 23   ALARM HORN & ACKNOWLEDGMENT SWITCH

24 <b>ALARM &amp; SHUTDOWN : (6.4.5.2)</b>				
25	FUNCTION	ALARM	TRIP	
26	<input type="checkbox"/> <input type="checkbox"/> LOW LUBE OIL PRESSURE	_____	_____	<input type="checkbox"/> <input type="checkbox"/> TURBINE VIBRATION
27	<input type="checkbox"/> <input type="checkbox"/> HI LUBE OIL FILTER Δ P	_____	_____	<input type="checkbox"/> <input type="checkbox"/> TURBINE AXIAL POSITION
28	<input type="checkbox"/> <input type="checkbox"/> HI SEAL OIL FILTER Δ P	_____	_____	<input type="checkbox"/> <input type="checkbox"/> GEAR VIBRATION
29	<input type="checkbox"/> <input type="checkbox"/> LOW LUBE OIL RESERVOIR LEV.	_____	_____	<input type="checkbox"/> <input type="checkbox"/> GEAR AXIAL POSITION
30	<input type="checkbox"/> <input type="checkbox"/> LOW SEAL OIL RESERVOIR LEV.	_____	_____	<input type="checkbox"/> <input type="checkbox"/> COMPRESSOR MOTOR SHUTDOWN
31	<input type="checkbox"/> <input type="checkbox"/> HI SEAL OIL LEVEL	_____	_____	<input type="checkbox"/> <input type="checkbox"/> TRIP & THROTTLE VALVE SHUT
32	<input type="checkbox"/> <input type="checkbox"/> LOW SEAL OIL LEVEL	_____	_____	<input type="checkbox"/> <input type="checkbox"/> HI TURB. STEAM SEAL LEAKAGE
33	<input type="checkbox"/> <input type="checkbox"/> HI SEAL OIL PRESSURE	_____	_____	<input type="checkbox"/> <input type="checkbox"/> HI COMPR. THRUST BRG. TEMP.
34	<input type="checkbox"/> <input type="checkbox"/> LOW SEAL OIL PRESSURE	_____	_____	<input type="checkbox"/> <input type="checkbox"/> <b>HI COMPR. JOURNAL BRG. TEMP.</b>
35	<input type="checkbox"/> <input type="checkbox"/> AUX. SEAL OIL PUMP START	_____	_____	<input type="checkbox"/> <input type="checkbox"/> HI DRIVER THRUST BRG. TEMP.
36	<input type="checkbox"/> <input type="checkbox"/> AUX. LUBE OIL PUMP START	_____	_____	<input type="checkbox"/> <input type="checkbox"/> <b>HI DRIVER JOURNAL BRG. TEMP.</b>
37	<input type="checkbox"/> <input type="checkbox"/> HI SEAL OIL OUTLET TEMP. (COOLER)	_____	_____	<input type="checkbox"/> <input type="checkbox"/> <b>HI GEAR THRUST BRG. TEMP.</b>
38	<input type="checkbox"/> <input type="checkbox"/> HI LIQUID LEV. SUCT. SEPARATOR	_____	_____	<input type="checkbox"/> <input type="checkbox"/> <b>HI GEAR JOURNAL BRG. TEMP.</b>
39	<input type="checkbox"/> <input type="checkbox"/> COMPRESSOR VIBRATION	_____	_____	<input type="checkbox"/> <input type="checkbox"/> COMPRESSOR Δ P
40	<input type="checkbox"/> <input type="checkbox"/> COMPRESSOR HI DISCH. TEMP.	_____	_____	<input type="checkbox"/> <input type="checkbox"/> LOW SEAL GAS PRESSURE
41	<input type="checkbox"/> <input type="checkbox"/> COMPRESSOR AXIAL POSITION	_____	_____	<input type="checkbox"/> <input type="checkbox"/> <b>HI COALESCING GAS/OIL FILTER Δ P</b>
41	<input type="checkbox"/> <input type="checkbox"/> HI LUBE OIL <b>SUPPLY</b> TEMPERATURE	_____	_____	<input type="checkbox"/> <input type="checkbox"/>

- 42 **CONTACTS:**
- 43 ALARM CONTACTS SHALL:  OPEN  CLOSE TO SOUND ALARM AND BE NORMALLY  ENERGIZED  DE-ENERGIZED
- 44 SHUTDOWN CONTACTS SHALL:  OPEN  CLOSE TO TRIP AND BE NORMALLY  ENERGIZED  DE-ENERGIZED
- 45 **NOTE:** NORMAL CONDITION IS WHEN COMPRESSOR IS IN OPERATION.

- 46 **MISCELLANEOUS:**
- 47  INSTRUMENT TAGGING REQUIRED.
- 48 ALARM AND SHUTDOWN SWITCHES SHALL BE SEPARATE.
- 49 PURCHASERS ELECTRICAL AND INSTRUMENT CONNECTIONS WITHIN THE CONFINES OF THE BASEPLATE AND CONSOLE SHALL
- 50 BE:  BROUGHT OUT TO TERMINAL BOXES.  MADE DIRECTLY BY THE PURCHASER.
- 51 COMMENTS REGARDING INSTRUMENTATION: \_\_\_\_\_
- 52

# ROTARY-TYPE POSITIVE- DISPLACEMENT COMPRESSOR DATA SHEET US CUSTOMARY UNITS

JOB NO. \_\_\_\_\_ ITEM NO. \_\_\_\_\_  
 REVISION NO. \_\_\_\_\_ DATE \_\_\_\_\_  
 PAGE 8 OF 9 BY \_\_\_\_\_

<p>1 APPLICABLE TO:    <input type="radio"/> PROPOSAL    <input type="radio"/> PURCHASE    <input type="radio"/> AS BUILT</p> <p>2 FOR _____</p> <p>3 SITE _____</p> <p>4 SERVICE _____</p> <p>5 MANUFACTURER _____ MODEL _____</p> <p>6 NOTE:    <input type="radio"/> INDICATES INFORMATION TO BE COMPLETED BY PURCHASER    <input type="checkbox"/> BY MANUFACTURER</p>	<p>UNIT _____</p> <p>DRIVEN EQUIP. _____</p> <p>NO. REQUIRED _____</p> <p>SERIAL NO. _____</p>
MOTOR DESIGN DATA	MOTOR DESIGN DATA (CONT'D)
<p>9 <b>APPLICABLE SPECIFICATIONS:</b></p> <p>10 <input type="radio"/> IEC _____    <input type="radio"/> NEMA _____</p> <p>11 <input type="radio"/> API 541 (6.1.2.2) _____</p> <p>12 <input type="radio"/> _____</p> <p>13 <b>SITE DATA:</b></p> <p>14 AREA:    <input type="radio"/> CL.    <input type="radio"/> GR.    <input type="radio"/> DIV.    <input type="radio"/> NON-HAZARDOUS</p> <p>15 <input type="radio"/> ALT. _____ FT.    <input type="radio"/> AMB. TEMPS: MAX. _____ °F, MIN _____ °F</p> <p>16 UNUSUAL CONDITIONS:    <input type="radio"/> DUST    <input type="radio"/> FUMES</p> <p>17 <input type="radio"/> OTHER _____</p> <p>18 <b>DRIVE SYSTEM:</b>    <input type="radio"/> DIRECT CONNECTED</p> <p>19                                    <input type="radio"/> GEAR</p> <p>20                                    <input type="radio"/> OTHER _____</p> <p>21 <b>TYPE MOTOR:</b> (6.1.2.1)</p> <p>22 <input type="radio"/> SQUIRREL CAGE INDUCTION    <input type="radio"/> NEMA DESIGN _____</p> <p>23 <input type="radio"/> SYNCHRONOUS _____</p> <p>24    <input type="radio"/> POWER FACTOR REQD. _____</p> <p>25 EXCITATION:    <input type="radio"/> BRUSHLESS    <input type="radio"/> SLIP RING</p> <p>26    <input type="radio"/> FIELD DISCHARGE RESISTOR BY MOTOR MFR.</p> <p>27 <input type="radio"/> WOUND ROTOR INDUCTION</p> <p>28 <input type="radio"/> _____</p> <p>29 <b>ENCLOSURE:</b> (6.1.2.1.c)</p> <p>30 <input type="radio"/> TEFC</p> <p>31 <input type="radio"/> TEWAC    <input type="radio"/> TEIGF, USING _____ GAS</p> <p>32    <input type="radio"/> DOUBLE WALL CARBON STEEL TUBES</p> <p>33    <input type="radio"/> WATER SUPPLY: PRESS. _____ PSIG TEMP. _____ °F</p> <p>34    <input type="radio"/> WATER ALLOW. <math>\Delta P</math> _____ PSI &amp; TEMP. RISE _____ °F</p> <p>35    <input type="radio"/> WATER SIDE MIN. CORR. ALLOW. _____ IN.</p> <p>36    AND FOUL FACTOR _____</p> <p>37    <input type="radio"/> (AIR) (GAS) SUPPLY PRESS. _____ PSIG</p> <p>38    <input type="radio"/> _____</p> <p>39 <input type="radio"/> WEATHER PROTECTED, TYPE _____</p> <p>40 <input type="radio"/> FORCED VENTILATED</p> <p>41 <input type="radio"/> OPEN-DRIPPROOF</p> <p>42 <input type="radio"/> OPEN</p> <p>43 _____</p> <p>44 _____</p> <p>45 <b>BASIC DATA:</b></p> <p>46 <input type="radio"/> _____ VOLTS    _____ PHASE    _____ HERTZ</p> <p>47 <input type="checkbox"/> NAMEPLATE HP _____ SERVICE FACTOR (6.1.2.1.g) _____</p> <p>48 <input type="radio"/> SYNCHRONOUS RPM _____</p> <p>49 <input type="radio"/> INSULATION: CLASS _____ TYPE _____</p> <p>50 <input type="radio"/> TEMP. RISE: _____ °F ABOVE _____ °F    BY _____</p> <p>51 _____</p> <p>52 _____</p>	<p><b>STARTING:</b> (6.2.1.1 b)</p> <p><input type="radio"/> FULL VOLTAGE    <input type="radio"/> REDUCED VOLTAGE _____ %</p> <p><input type="radio"/> LOADED    <input type="radio"/> UNLOADED</p> <p><input type="radio"/> VOLTAGE DIP _____ %</p> <p><b>VIBRATION:</b></p> <p><input type="radio"/> IEC STANDARD    <input type="radio"/> NEMA STANDARD _____</p> <p><b>NOISE:</b></p> <p><input type="radio"/> IEC STANDARD    <input type="radio"/> NEMA STANDARD _____</p> <p style="text-align: center;"><b>ACCESSORY EQUIPMENT</b></p> <p><input type="radio"/> BASEPLATE    <input type="radio"/> SOLEPLATE    <input type="radio"/> STATOR SHIFT</p> <p><input type="radio"/> MFR. STD. FANS    <input type="radio"/> NON-SPARKING FANS</p> <p><input type="radio"/> D.C. EXCITATION:</p> <p>    <input type="checkbox"/> KW REQD _____    <input type="radio"/> VOLTS _____</p> <p>    BY:    <input type="radio"/> PURCHASER    <input type="radio"/> MANUFACTURER</p> <p>    DESCRIPTION _____</p> <p><input type="radio"/> <b>ENCLOSED COLLECTOR RINGS:</b></p> <p>    <input type="radio"/> PURGED: MEDIUM _____ PRESS. _____ PSIG</p> <p>    <input type="radio"/> EXPLOSION-RESISTANT NON-PURGED</p> <p>    <input type="radio"/> FORCED VENTILATION</p> <p>        <input type="checkbox"/> CFM _____ PRESS. DROP _____ IN. H<sub>2</sub>O</p> <p><input type="radio"/> <b>BEARING TEMP DEVICES:</b></p> <p>    <input type="checkbox"/> LOCATION _____</p> <p>    <input type="checkbox"/> DESCRIPTION _____</p> <p>    <input type="checkbox"/> SET @ _____ °F FOR ALARM    _____ °F FOR SHUTDOWN</p> <p><input type="radio"/> <b>SPACE HEATERS:</b></p> <p>    <input type="checkbox"/> _____ KW    <input type="radio"/> _____ VOLTS    _____ PHASE    _____ HERTZ</p> <p>    <input type="radio"/> MAX. SHEATH TEMP. _____ °F</p> <p><b>WINDING TEMPERATURE DETECTORS:</b></p> <p><input type="radio"/> THERMISTORS:    NO./PHASE _____</p> <p>    TYPE:    <input type="radio"/> POS. TEMP. COEFF.    <input type="radio"/> NEG. TEMP. COEFF.</p> <p>    TEMPERATURE SWITCH:    <input type="radio"/> YES    <input type="radio"/> NO</p> <p><input type="radio"/> RESISTANCE TEMPERATURE DETECTORS: NO./PHASE _____</p> <p>    <input type="checkbox"/> RESISTANCE MATL. _____ <input type="checkbox"/> _____ OHMS</p> <p>    SELECTOR SWITCH &amp; INDICATOR BY:    <input type="radio"/> PURCHR.    <input type="radio"/> MFR.</p> <p>    <input type="checkbox"/> MAX. STATOR WINDING TEMPS:</p> <p>        _____ °F FOR ALARM    _____ °F FOR SHUTDOWN</p> <p><b>WINDING TEMP. DETECTOR &amp; SPACE HEATER LEADS:</b></p> <p><input type="radio"/> IN SAME CONDUIT BOX</p> <p><input type="radio"/> IN SEPARATE CONDUIT BOXES</p> <p><input type="radio"/> <b>MOTOR ARRANGED FOR DIFFERENTIAL PROTECTION:</b></p> <p>    <input type="radio"/> SELF-BALANCE PRIMARY CURRENT METHOD</p> <p>    <input type="radio"/> C.T. DESCRIPTION _____</p> <p>    <input type="radio"/> EXTENDED LEADS    <input type="checkbox"/> LENGTH _____ FT.</p> <p><input type="radio"/> <b>SURGE CAPACITORS</b></p>

# ROTARY-TYPE POSITIVE- DISPLACEMENT COMPRESSOR DATA SHEET US CUSTOMARY UNITS

JOB NO. \_\_\_\_\_ ITEM NO. \_\_\_\_\_  
 REVISION NO. \_\_\_\_\_ DATE \_\_\_\_\_  
 PAGE 9 OF 9 BY \_\_\_\_\_

ACCESSORY EQUIPMENT (CONT'D)	MANUFACTURER'S DATA (CONT'D.)
1	
2 <input type="radio"/> LIGHTNING ARRESTERS	BEARING: TYPE _____ LUBR. _____
3 <input type="radio"/> C.T. FOR AMMETER	LUBE OIL REQUIRED: _____ GPM @ _____ PSIG
4 <input type="radio"/> DESCRIPTION _____	TOTAL SHAFT END FLOAT _____
5 MAIN CONDUIT BOX SIZED FOR:	LIMIT END FLOAT TO _____
6 <input type="radio"/> MAIN MOTOR LEADS <input type="radio"/> TYPE: _____	MOTOR ROTOR: <input type="checkbox"/> SOLID <input type="checkbox"/> SPLIT
7 <input type="radio"/> INSULATED <input type="radio"/> NON-INSULATED	MOTOR HUB: <input type="checkbox"/> SOLID <input type="checkbox"/> SPLIT
8 <input type="radio"/> C.T.'S FOR DIFF. PROTECTION (MOUNTED BY _____)	FOR TEWAC & TEIGF MOTORS:
9 <input type="radio"/> SURGE CAPACITORS (MOUNTED BY _____)	COOLING WATER REQD. _____ CFM
10 <input type="radio"/> LIGHTNING ARRESTERS (MOUNTED BY _____)	C.W. TEMP. RISE _____ °F PRESS. DROP _____ PSIG
11 <input type="radio"/> C.T. FOR AMMETER (MOUNTED BY _____)	(AIR) (GAS) REQD. _____ CFM PRESS. MAINT. _____ IN. H <sub>2</sub> O
12 <input type="radio"/> SPACE FOR STRESS CONES	CURVES REQD. BASED ON MTR SATURATION @ RATED
13 <input type="radio"/> AIR FILTERS:	VOLTAGE:
14 <input type="checkbox"/> MFR _____ <input type="checkbox"/> TYPE _____	<input type="radio"/> SPEED VS TORQUE (ALSO @ _____ % RATED VOLTAGE)
15 <input type="checkbox"/> MANUFACTURER'S DATA	<input type="radio"/> SPEED VS. POWER FACTOR
16 MANUFACTURER _____	<input type="radio"/> SPEED VS CURRENT
17 FRAME NO. _____ FULL LOAD RPM (IND.) _____	<b>WEIGHT (LBS):</b>
18 EFFICIENCY: F.L. _____ 3/4 L _____ 1/2 L _____	NET WEIGHT _____ SHIPPING WEIGHT _____
19 PWR. FACTOR (IND.): F.L. _____ 3/4 L _____ 1/2 L _____	ROTOR WEIGHT _____ MAX. ERECTION WT. _____
20 CURRENT (RATED VOLT.): FULL LOAD _____ LOCKED ROT. _____	MAX. MAINT. WT. (IDENTIFY) _____
21 LOCKED ROTOR POWER FACTOR _____	<b>DIMENSIONS (FEET &amp; INCHES):</b>
22 LOCKED ROTOR WITHSTAND TIME (COLD START) _____	L _____ W _____ H _____
23 TORQUES (FT-LBS): FULL LOAD _____	<b>SHOP INSPECTION AND TESTS</b>
24 LOCKED ROTOR _____ STARTING (SYN.) _____	<b>REQUIRED                      WITNESS</b>
25 PULL-UP (IND.) _____ PULL-IN (SYN.) _____	SHOP INSPECTION <input type="radio"/> <input type="radio"/>
26 BREAKDOWN (IND.) _____ PULL-OUT (SYN.) _____	TESTING PER <input type="radio"/> IEC <input type="radio"/> NEMA <input type="radio"/> <input type="radio"/>
27 _____	MFR. STD. SHOP TESTS <input type="radio"/> <input type="radio"/>
28 OPEN CIRCUIT TIME CONSTANT (SEC.) _____	IMMERSION TEST <input type="radio"/> <input type="radio"/>
29 SYMMETRICAL CONTRIBUTION TO 30 TERMINAL FAULT:	SPECIAL TESTS (LIST BELOW)
30 AT 1/2 CYCLES _____ AT 5 CYCLES _____	_____ <input type="radio"/> <input type="radio"/>
31 REACTANCES: SUB-TRANSIENT (X'd) _____	_____ <input type="radio"/> <input type="radio"/>
32 TRANSIENT (X'd) _____ SYNCHRONOUS (X <sub>s</sub> ) _____	_____ <input type="radio"/> <input type="radio"/>
33 A.C. STATOR RESISTANCE _____ OHMS @ _____ °F	_____ <input type="radio"/> <input type="radio"/>
34 RATED KVA _____	<b>PAINTING:</b>
35 KVA INRUSH @ FULL VOLT. & LOCKED ROTOR (SYN.) _____ %	<input type="radio"/> MANUFACTURER'S STANDARD
36 KVA. @ FULL VOLTAGE & 95% SPEED _____ %	<input type="radio"/> OTHER: _____
37 MAX. LINE CURR. IN STATOR ON 1ST SLIP CYC. @ PULL-OUT	<b>SHIPMENT (7.4.1)</b>
38 (SYN.) _____	<input type="radio"/> DOMESTIC <input type="radio"/> EXPORT <input type="radio"/> EXPORT BOXING REQUIRED
39 ACCELERATION TIME (MTR ONLY @ RATED VOLT.) _____ SEC	<input type="radio"/> OUTDOOR STORAGE OVER 3 MONTHS
40 ACCEL. TIME (MTR & LOAD @ 85% RATED VOLT.) _____ SEC	
41 ROTOR/FIELD WK <sup>2</sup> @ MTR SHAFT (LB-FT <sup>2</sup> ) _____	<b>REMARKS:</b>
42 ROTATION FACING COUPLING END _____	_____
43 NO. OF STARTS PER HOUR _____	_____
44 _____	_____
45 FIELD DISCHARGE RESISTOR _____ OHMS	_____
46 RATED EXCITATION FIELD VOLTAGE _____ D.C.	_____
47 RESISTANCE OF EXCITATION FIELD @ 77°F _____ OHMS	_____
48 EXCITATION FIELD AMPS @ FULL LOAD & RATED P.F. _____	_____
49 EXCITATION FIELD AMPS: MAX. _____ MIN. _____	_____
50 EXCITATION FIELD <input type="checkbox"/> RHEOSTAT <input type="checkbox"/> FIXED RESTR REQD.	_____
51 SUPPLIED BY _____	_____

.....

# ROTARY-TYPE POSITIVE- DISPLACEMENT COMPRESSOR DATA SHEET SI UNITS

JOB NO. \_\_\_\_\_ ITEM NO. \_\_\_\_\_  
 PURCHASE ORDER NO. \_\_\_\_\_ DATE \_\_\_\_\_  
 REQUISITION NO. \_\_\_\_\_  
 INQUIRY NO. \_\_\_\_\_  
 PAGE 1 OF 9 BY \_\_\_\_\_

DRAWING UNITS:  SI  US CUSTOM  DUAL (4.3)

1 APPLICABLE TO:  PROPOSAL  PURCHASE  AS BUILT DATE \_\_\_\_\_ REVISION \_\_\_\_\_  
 2 FOR \_\_\_\_\_ UNIT \_\_\_\_\_  
 3 SITE \_\_\_\_\_ SERIAL NO. \_\_\_\_\_  
 4 SERVICE \_\_\_\_\_ NO. REQUIRED \_\_\_\_\_  
 5 MANUFACTURER \_\_\_\_\_ MODEL \_\_\_\_\_ DRIVER (6.1) \_\_\_\_\_  
 6 NOTE:  INDICATES INFORMATION TO BE COMPLETED BY PURCHASER  BY MANUFACTURER

### OPERATING CONDITIONS

ALL DATA ON PER UNIT BASIS	NORMAL (3.33) (5.1.3)	MAXIMUM	OTHER CONDITIONS (5.1.4)			
			A	B	C	D
11 <input type="radio"/> CERTIFIED POINT (✓) (5.1.4)						
12 <input type="radio"/> GAS HANDLED (ALSO SEE PAGE 2)						
13 <input type="radio"/> Required Capacity Nm <sup>3</sup> /h (1.013 bar & 0 °C) <b>(DRY) (3.46 &amp; 3.60)</b>						
14 <input type="radio"/> WEIGHT FLOW, kg/hr--(WET)(DRY)						
15 <b>INLET CONDITIONS:</b> <input type="radio"/> COMPRESSOR INLET FLANGE <input type="radio"/> CUSTOMER CONNECTION						
16 <input type="radio"/> PRESSURE - <b>absolute (bar)</b>						
17 <input type="radio"/> TEMPERATURE (°C)						
18 <input type="radio"/> RELATIVE HUMIDITY (%)						
19 <input type="radio"/> MOLECULAR WEIGHT (M)						
20 <input type="checkbox"/> Cp/Cv (K <sub>1</sub> ) OR (K <sub>AVG</sub> ) (5.1.15.4)						
21 <input type="checkbox"/> COMPRESSIBILITY (Z <sub>1</sub> ) OR (Z <sub>AVG</sub> ) (5.1.15.5)						
22 <input type="checkbox"/> INLET VOLUME FLOW (m <sup>3</sup> /h) (3.19)						
23 <b>DISCHARGE CONDITIONS:</b> <input type="radio"/> COMPRESSOR DISCHARGE FLANGE <input type="radio"/> CUSTOMER CONNECTION						
24 <input type="radio"/> PRESSURE - <b>absolute (bar)</b>						
25 <input type="checkbox"/> TEMPERATURE (°C)						
26 <input type="checkbox"/> Cp/Cv (K <sub>2</sub> ) OR (K <sub>AVG</sub> )						
27 <input type="checkbox"/> COMPRESSIBILITY (Z <sub>2</sub> ) OR (Z <sub>AVG</sub> )						
28 <input type="checkbox"/> <b>DEW POINT (°C)</b>						
29 <input type="radio"/> <b>OIL CARRYOVER (PPM-BY WT.)</b>						
30 <input type="checkbox"/> kW REQUIRED (ALL LOSSES INCL)						
31 <input type="checkbox"/> SPEED (RPM)						
32 <input type="checkbox"/> PRESSURE RATIO (R)						
33 <input type="checkbox"/> VOLUMETRIC EFFICIENCY (%)						
34 <input type="checkbox"/> SILENCER Δ P <b>(bar) (6.9.3)</b>						
35 <input type="radio"/> SETTLE OUT PRESSURE - <b>absolute (bar)</b> (5.1.5)						
36 <input type="checkbox"/> PERFORMANCE CURVE NO.						

37

38 **PROCESS CONTROL:** (6.4.2.1)

39 METHOD:  SLIDE VALVE \_\_\_\_\_

40  BYPASS FROM \_\_\_\_\_ TO \_\_\_\_\_

41  BYPASS:  MANUAL  AUTO

42  SPEED VARIATION FROM \_\_\_\_\_ TO \_\_\_\_\_

43  OTHER \_\_\_\_\_

44 SIGNAL:  SOURCE \_\_\_\_\_

45  TYPE \_\_\_\_\_

46  RANGE: FOR PNEUMATIC CONTROL \_\_\_\_\_ RPM @ \_\_\_\_\_ (bar) & \_\_\_\_\_ RPM @ \_\_\_\_\_ (bar)

47  OTHER \_\_\_\_\_

48 **SERVICE:**  SPECIAL PURPOSE (3.58)  GENERAL PURPOSE (3.15)

49  CONTINUOUS  INTERMITTENT  STANDBY (3.62)  DRY SCREW (3.9)  FLOODED SCREW (3.12)

50 **REMARKS:** Unless otherwise noted, all pressures are GAGE pressures. (Example: bar refers to gage pressure; bar abs. refers to absolute pressure)

51 \_\_\_\_\_

52 \_\_\_\_\_

53 \_\_\_\_\_

**ROTARY-TYPE POSITIVE-  
DISPLACEMENT COMPRESSOR  
DATA SHEET  
SI UNITS**

JOB NO. \_\_\_\_\_ ITEM NO. \_\_\_\_\_  
 REVISION NO. \_\_\_\_\_ DATE \_\_\_\_\_  
 PAGE 2 OF 9 BY \_\_\_\_\_

1	GAS ANALYSIS (5.1.15.4)	NOR- MAL	MAX- IMUM	OTHER CONDITIONS				REMARKS
				A	B	C	D	
2	<input type="radio"/> MOL % <input type="radio"/> _____							
3								
4	AIR							
5	OXYGEN							
6	NITROGEN							
7	WATER VAPOR							
8	CARBON MONOXIDE							
9	CARBON DIOXIDE							
10	HYDROGEN SULFIDE							(5.11.1.10)
11	HYDROGEN							
12	METHANE							
13	ETHYLENE							
14	ETHANE							
15	PROPYLENE							
16	PROPANE							
17	i-BUTANE							
18	n-BUTANE							
19	i-PENTANE							
20	n-PENTANE							
21	HEXANE PLUS							
22								
23								
24	<input type="radio"/> CORROSIVE							(5.11.1.7)
25	<input type="radio"/> SOLID PARTICLE							(5.1.25)
26	<input type="radio"/> LIQUID PARTICLE							(5.1.25)
27	<input type="radio"/> NACE MATERIALS							(5.11.1.10)
28	TOTAL							
29	AVG. MOL. WT.							
30	<b>SITE DATA:</b>				<b>NOISE SPECIFICATIONS:</b> (5.1.19)			
31	<b>LOCATION:</b>				<input type="radio"/> APPLICABLE TO MACHINE SEE SPECIFICATION _____ <input type="radio"/> APPLICABLE TO NEIGHBORHOOD SEE SPECIFICATION _____ <input type="radio"/> YES <input type="radio"/> NO			
32	<input type="radio"/> INDOOR	<input type="radio"/> HEATED	<input type="radio"/> UNDER ROOF	SOUND LEVEL _____ dB @ _____ m				
33	<input type="radio"/> OUTDOOR	<input type="radio"/> UNHEATED	<input type="radio"/> PARTIAL SIDES	dB RE: <b>20 MICRO PASCAL</b>				
34	<input type="radio"/> GRADE	<input type="radio"/> MEZZANINE	<input type="radio"/> _____	<b>APPLICABLE SPECIFICATIONS:</b>				
35	<input type="radio"/> WINTERIZATION REQ'D.	<input type="radio"/> TROPICALIZATION REQ'D.		API 619 POSITIVE DISPLACEMENT ROTARY COMPRESSORS				
36	<input type="radio"/> ELEVATION _____ m	BAROMETER _____ (bar abs.)		<input type="radio"/> ACOUSTIC _____				
37	<input type="radio"/> RANGE OF AMBIENT TEMPS.:	DRY BULB _____ WET BULB _____ SITE RATED °C _____ NORMAL °C _____ MAXIMUM °C _____ MINIMUM °C _____		<input type="radio"/> MOTOR _____				
38								
39								
40								
41								
42	<b>ELECTRICAL AREA CLASSIFICATION:</b> (5.1.18)							
43	<input type="radio"/> ZONE _____	GROUP _____	CLASS _____					
44	<input type="radio"/> AREA: CL. _____	GR. _____	DIV. _____					
45	<b>UNUSUAL CONDITIONS:</b>				<b>PAINTING:</b>			
46	<input type="radio"/> OTHER _____	<input type="radio"/> DUST	<input type="radio"/> FUMES	<input type="radio"/> MANUFACTURER'S STD.				
47	_____			<input type="radio"/> OTHER _____				
48	_____							
49	_____							
50	<input type="radio"/> VENDOR HAVING UNIT RESPONSIBILITY: (3.65) _____				<b>SHIPMENT:</b> (7.4.1)			
51					<input type="radio"/> DOMESTIC <input type="radio"/> EXPORT <input type="radio"/> EXPORT BOXING REQ'D			
52					<input type="radio"/> LONG TERM STORAGE FOR _____ MONTHS			
53	<b>REMARKS:</b> _____							



# ROTARY-TYPE POSITIVE- DISPLACEMENT COMPRESSOR DATA SHEET SI UNITS

JOB NO. \_\_\_\_\_ ITEM NO. \_\_\_\_\_  
 REVISION NO. \_\_\_\_\_ DATE \_\_\_\_\_  
 PAGE 3 OF 9 BY \_\_\_\_\_

<p><input type="checkbox"/> <b>SPEEDS:</b></p> <p>2 MAX. CONT. (3.26) _____ RPM TRIP (3.64) _____ RPM</p> <p>3 MAX. TIP SPEEDS: _____ m/s @ MAX. OPER. SPEED</p> <p>4 MIN. ALLOW (3.30) _____ RPM</p> <p>5 <input type="checkbox"/> LATERAL CRITICAL SPEEDS: (5.7.1.4)</p> <p>6 FIRST CRITICAL _____ RPM</p> <p>7 DAMPED _____ UNDAMPED _____</p> <p>8 MODE SHAPE _____</p> <p>9 LATERAL CRITICAL SPEED - BASIS:</p> <p>10 <input type="radio"/> DAMPED UNBALANCE RESPONSE ANALYSIS</p> <p>11 <input type="checkbox"/> OTHER TYPE ANALYSIS: _____ (SPECIFY)</p> <p>12 <input type="checkbox"/> POCKET PASSING FREQUENCY: _____ Hz</p> <p>13 <input type="checkbox"/> TORSIONAL CRITICAL SPEEDS: (5.7.2)</p> <p>14 FIRST CRITICAL _____ RPM</p> <p>15 SECOND CRITICAL _____ RPM</p> <p>16 <input type="checkbox"/> VIBRATION: (5.7.3.6)</p> <p>17 HOUSING _____ mm/s RMS</p> <p>18 SHAFT _____</p> <p>19 <input type="checkbox"/> ROTATION, LOOK AT COMPRESSOR DRIVEN END: <input type="checkbox"/> CW <input type="checkbox"/> CCW</p> <p>20 <input type="checkbox"/> CASING:</p> <p>21 MODEL _____</p> <p>22 CASING SPLIT _____</p> <p>23 MATERIAL _____ <input type="radio"/> CLADDING (5.2.10)</p> <p>24 OPERATION: <input type="radio"/> DRY <input type="radio"/> FLOODED, w/ _____ LIQUID</p> <p>25 THICKNESS (mm.) _____ CORR. ALLOW (mm.) _____</p> <p>26 MAX. ALLOWABLE WORK PRESS. (3.25) _____ (bar)</p> <p>27 RELIEF VALVE SETTING _____ (bar)</p> <p>28 MARGIN FOR ACCUMULATION _____ (bar)</p> <p>29 LEAK TEST GAS: _____ PRESS (bar)(kPa): _____ (7.3.3.4.3.1)</p> <p>30 TEST PRESS. (bar) (7.3.4.6) _____ HYDRO (7.3.2) _____</p> <p>31 MAX. ALLOW. TEMP. _____ °C MIN. OPER. TEMP. _____ °C</p> <p>32 COOLING JACKET <input type="checkbox"/> YES <input type="checkbox"/> NO</p> <p>33 <input type="checkbox"/> ROTORS: (5.5.1)</p> <p>34 DIAMETER (mm.): MALE: _____ FEMALE: _____</p> <p>35 NO. LOBES: MALE _____ FEMALE _____</p> <p>36 TYPE: _____</p> <p>37 TYPE FABRICATION _____</p> <p>38 MATERIAL _____</p> <p>39 MAX. YIELD STRENGTH (N/mm<sup>2</sup>) _____</p> <p>40 BRINELL HARDNESS. MAX. _____ MIN. _____</p> <p>41 ROTOR LENGTH TO DIAMETER RATIO (L/D) M: _____</p> <p>42 ROTOR CLEARANCE (mm) _____</p> <p>43 _____</p> <p>44 _____</p> <p>45 INTERNALLY COOLED <input type="checkbox"/> YES <input type="checkbox"/> NO</p> <p>46 _____</p> <p>47 _____</p> <p>48 _____</p> <p>49 _____</p> <p>50 _____</p> <p>51 <b>REMARKS:</b> _____</p> <p>52 _____</p> <p>53 _____</p>	<p><input type="checkbox"/> <b>SHAFT:</b> (5.5.1.2)</p> <p>MATERIAL _____</p> <p>DIA @ ROTORS (mm) _____ DIA @ COUPLING (mm) _____</p> <p>SHAFT END. <input type="checkbox"/> TAPERED <input type="checkbox"/> CYLINDRICAL (5.5.1.5 &amp; 5.5.1.6)</p> <p><b>SHAFT SLEEVES:</b></p> <p><input type="radio"/> AT SHAFT SEALS _____ <input type="checkbox"/> MATL. _____</p> <p><input type="checkbox"/> <b>TIMING GEARS:</b> (5.5.2)</p> <p>PITCH LINE DIAMETER (mm) MALE: _____ FEMALE: _____</p> <p>MATERIAL _____ TYPE _____</p> <p><input type="checkbox"/> <b>SHAFT SEALS:</b> (5.6)</p> <p><input type="radio"/> SEAL SYSTEM TYPE (5.6.1.7)</p> <p><input type="checkbox"/> OIL LEAKAGE (CC/MIN/SEAL) _____</p> <p><input type="radio"/> TYPE BUFFER GAS (5.6.2.2) _____</p> <p><input type="checkbox"/> BUFFER GAS FLOW (PER SEAL)</p> <p>NORMAL: _____ kg/hr. @ _____ (bar)</p> <p>MAX.: _____ kg/hr. @ _____ (bar)</p> <p><input type="checkbox"/> <b>BEARING HOUSING:</b> (5.9)</p> <p>TYPE (SEPARATE, INTEGRAL) _____ SPLIT _____</p> <p>MATERIAL _____</p> <p><input type="checkbox"/> <b>HYDRODYNAMIC RADIAL BEARINGS: (IDENTIFY HIGHEST LOADED BEARING) (5.8)</b></p> <p>TYPE _____ SPAN (mm) _____</p> <p>AREA (mm<sup>2</sup>) _____ LOADING (N/mm<sup>2</sup>): ACT. _____ ALLOW. _____</p> <p>NO. PADS _____ ROTOR ON _____ OR BETWEEN _____ PADS</p> <p>PAD MATERIAL _____</p> <p>TYPE BABBITT _____ THICKNESS _____ (mm)</p> <p><input type="radio"/> TEMP SENSORS (5.8.1.5)</p> <p><input type="radio"/> TC <input type="radio"/> RTD TYPE _____</p> <p>NO PER BRG _____</p> <p><input type="checkbox"/> <b>ROLLING ELEMENT RADIAL BEARING (5.8.2)</b></p> <p>TYPE: _____, Ndm: _____</p> <p>_____</p> <p>_____</p> <p><b>ENERGY DENSITY (kW-RPM):</b> _____</p> <p><input type="checkbox"/> <b>HYDRODYNAMIC THRUST BEARING: (IDENTIFY HIGHEST LOADED BEARING)</b></p> <p>"(5.8) _____ TYPE _____</p> <p>MFR. _____ AREA (mm<sup>2</sup>) _____</p> <p>LOADING (N/mm<sup>2</sup>): _____ ACT. _____ ALLOW. _____</p> <p>NUMBER OF PADS _____</p> <p>PAD MATERIAL _____</p> <p>TYPE BABBITT _____ THICKNESS _____ (mm)</p> <p><input type="radio"/> TEMP SENSORS (5.8.1.5)</p> <p><input type="radio"/> TC <input type="radio"/> RTD TYPE _____</p> <p>NO PER BRG _____ <input type="checkbox"/> ACTIVE <input type="checkbox"/> INACTIVE</p> <p><input type="checkbox"/> <b>ROLLING ELEMENT THRUST BEARING (5.8.2)</b></p> <p>TYPE: _____, Ndm: _____</p> <p>_____</p> <p>_____</p> <p><b>ENERGY DENSITY (kW-RPM):</b> _____</p>
---	--

**ROTARY-TYPE POSITIVE-  
DISPLACEMENT COMPRESSOR  
DATA SHEET  
SI UNITS**

JOB NO. \_\_\_\_\_ ITEM NO. \_\_\_\_\_  
 REVISION NO. \_\_\_\_\_ DATE \_\_\_\_\_  
 PAGE 4 OF 9 BY \_\_\_\_\_

1	<input type="checkbox"/> <b>PROCESS CONNECTIONS - COMPRESSOR CASING(5.3):</b>						<b>AXIAL POSITION DETECTOR: (6.4.4.3.3)</b>					
2		SIZE	RATING	FACING	ORIENTATION		<input type="radio"/> IN ACCORDANCE WITH: API 670 <input type="radio"/> TYPE _____ <input type="checkbox"/> MODEL _____ <input type="radio"/> MFR. _____ <input type="checkbox"/> NO. REQ'D _____ <input type="radio"/> OSCILLATOR-DETECTORS SUPPLIED BY _____ <input type="radio"/> MFR. _____ <input type="checkbox"/> MODEL _____ <input type="radio"/> MONITOR SUPPLIED BY _____ <input type="radio"/> LOCATION _____ ENCLOSURE _____ <input type="radio"/> MFR. _____ <input type="checkbox"/> MODEL _____ <input type="checkbox"/> SCALE RANGE _____ <input type="radio"/> ALARM: <input type="checkbox"/> SET @ _____ <input type="radio"/> SHUTDOWN: <input type="checkbox"/> SET @ _____ <input type="radio"/> TIME DELAY _____					
3	INLET											
4	DISCHARGE											
5												
6	<input type="checkbox"/> <b>PROCESS CONNECTIONS - CUSTOMER INTERFACE:</b>											
7	INLET											
8	DISCHARGE											
9												
10	<input type="checkbox"/> <b>CASING - ALLOWABLE PIPING FORCES AND MOMENTS: (5.4)</b>											
11		INLET		DISCHARGE								
12		FORCE	MOMT	FORCE	MOMT	FORCE	MOMT					
13		N	N-m	N	N-m	N	N-m					
14	AXIAL	X										
15	VERTICAL	Y										
16	HORIZ. 90°	Z										
17												
18												
19	AXIAL	X										
20	VERTICAL	Y										
21	HORIZ. 90°	Z										
22	<input type="checkbox"/> <b>OTHER CONNECTIONS:</b>											
23	SERVICE:	NO	SIZE	TYPE/RATING								
24	LUBE OIL INLET											
25	LUBE OIL OUTLET											
26	SEAL OIL INLET											
27	SEAL OIL OUTLET											
28	CASING DRAINS (4.3.4)											
29	VENTS											
30	COOLING WATER <b>INLET</b>											
31	<b>COOLING WATER OUTLET</b>											
32	<b>LIQUID INJECTION</b>											
33	<b>OIL INJECTION</b>											
34	PURGE FOR:											
35	BRG. HOUSING											
36	BETWEEN BRG. & SEAL											
37	BETWEEN SEAL & GAS											
38	<input type="radio"/> <b>OTHER</b>											
39												
40	<input type="checkbox"/> <b>VIBRATION DETECTORS: (6.4.4.3)</b>						<b>BASEPLATE &amp; SOLEPLATES: (6.3.2 &amp; 6.3.3)</b>					
41	<input type="radio"/> IN ACCORDANCE WITH: API670 _____						SOLE PLATES FOR: <input type="radio"/> COMPRESSOR <input type="radio"/> GEAR <input type="radio"/> DRIVER					
42	<input type="radio"/> TYPE: <input type="checkbox"/> SEISMIC <input type="checkbox"/> DISPLACEMENT						BASEPLATE:					
43	<input type="checkbox"/> MODEL _____						<input type="radio"/> COMMON (UNDER COMP. GEAR & DRIVER)					
44	<input type="radio"/> MFR. _____						<input type="radio"/> UNDER COMP. ONLY <input type="radio"/> OTHER _____					
45	<input type="radio"/> NO. AT SHAFT/HOUSING _____ TOTAL NO. _____						<input type="radio"/> DECKED WITH NON-SKID DECK PLATE <input type="radio"/> OPEN CONSTR.					
46	<input type="radio"/> OSCILLATOR-DETECTORS SUPPLIED BY _____						<input type="radio"/> DRIP RIM <input type="radio"/> WITH OPEN DRAIN <input type="radio"/> SUBPLATE					
47	<input type="radio"/> MFR. _____ <input type="checkbox"/> MODEL _____						<input type="radio"/> HORIZONTAL ADJUSTING SCREWS FOR EQUIPMENT					
48	<input type="radio"/> MONITOR SUPPLIED BY _____						<input type="radio"/> SUITABLE FOR COLUMN SUPPORT (6.3.2.4)					
49	<input type="radio"/> LOCATION _____ ENCLOSURE _____						<input type="radio"/> SUITABLE FOR PERIMETER SUPPORT					
50	<input type="radio"/> MFR. _____ <input type="checkbox"/> MODEL _____						<input type="radio"/> EPOXY GROUT/EPOXY PRIMER (6.3.1.7)					
51	<input type="checkbox"/> SCALE RANGE _____ <input type="radio"/> ALARM. <input type="checkbox"/> SET @ _____											
52	<input type="radio"/> SHUTDN: <input type="checkbox"/> SET @ _____ <input type="radio"/> TIME DLY. _____ SEC											
53	<input type="radio"/> PHASE REFERENCE TRANSDUCER						<b>LUBE OIL SYSTEM (5.10)</b>					
							<input type="radio"/> LUBRICANT MANUFACTURER _____					
							<input type="radio"/> LUBRICANT TYPE _____ GRADE (ISO 3448) _____					
							<input type="radio"/> 614 LUBE OIL SYSTEM (5.10.2.3 & 5.10.3, APPENDIX -D)					
							<input type="radio"/> COMMON (5.10.2.1) <input type="radio"/> DEDICATED SYSTEM					
							<input type="radio"/> OIL FILTER (5.10.3.6)					
							<input type="radio"/> OIL COOLER (5.10.3.8): TYPE _____ NO: _____					
							<input type="radio"/> OIL PUMP (5.10.3.9): TYPE _____ NO: _____					
							<input type="radio"/> OIL SEPARATOR (5.10.3.10)					
							<input type="checkbox"/> TYPE _____ <input type="checkbox"/> NO _____					
							<input type="checkbox"/> OIL CARRYOVER (PPM-BY WT.) (LITER/DAY) _____					
							<input type="checkbox"/> RETENTION TIME (MIN) _____					
							<input type="checkbox"/> RELIEF VALVE <input type="checkbox"/> ELECTRIC HEATER					
							<input type="checkbox"/> OTHER _____					

# ROTARY-TYPE POSITIVE- DISPLACEMENT COMPRESSOR DATA SHEET SI UNITS

JOB NO. \_\_\_\_\_ ITEM NO. \_\_\_\_\_  
 REVISION NO. \_\_\_\_\_ DATE \_\_\_\_\_  
 PAGE 5 OF 9 BY \_\_\_\_\_

**1 UTILITY CONDITIONS: (ALL UNITS ARE GAUGE)**

	STEAM	DRIVERS	HEATING
3	INLET MIN. _____ (bar) _____ °C	_____ (bar) _____ °C	_____ (bar) _____ °C
4	NORM _____ (bar) _____ °C	_____ (bar) _____ °C	_____ (bar) _____ °C
5	MAX. _____ (bar) _____ °C	_____ (bar) _____ °C	_____ (bar) _____ °C
6	EXHAUST MIN. _____ (bar) _____ °C	_____ (bar) _____ °C	_____ (bar) _____ °C
7	NORM _____ (bar) _____ °C	_____ (bar) _____ °C	_____ (bar) _____ °C
8	MAX. _____ (bar) _____ °C	_____ (bar) _____ °C	_____ (bar) _____ °C

**9 ELECTRICITY:**

	DRIVERS	HEATING	CONTROL	SHUT-DOWN
10	_____	_____	_____	_____
11	VOLTAGE _____	_____	_____	_____
12	HERTZ _____	_____	_____	_____
13	PHASE _____	_____	_____	_____

**14 COOLING WATER**

15 TEMP. INLET \_\_\_\_\_ °C MAX. RETURN \_\_\_\_\_ °C

16 PRESS. NORM \_\_\_\_\_ (bar) DESIGN \_\_\_\_\_ (bar)

17 MIN. RETURN \_\_\_\_\_ (bar) MAX. ALLOW Δ P \_\_\_\_\_ (bar)

18 WATER SOURCE \_\_\_\_\_

**19 INSTRUMENT AIR:**

20 MAX PRESS \_\_\_\_\_ (bar) MIN. \_\_\_\_\_ (bar)

**21 TOTAL UTILITY CONSUMPTION:**

22	COOLING WATER _____	m <sup>3</sup> /h
23	STEAM, NORMAL _____	kg/h
24	STEAM, MAX _____	kg/h
25	INSTRUMENT AIR _____	Nm <sup>3</sup> /h
26	HP (DRIVER) _____	kW

**WEIGHTS (KG):**

COMPR. \_\_\_\_\_ GEAR \_\_\_\_\_ DRIVER \_\_\_\_\_ BASE \_\_\_\_\_

ROTORS: COMPR. \_\_\_\_\_ DRIVER \_\_\_\_\_ GEAR \_\_\_\_\_

COMPR. UPPER CASE \_\_\_\_\_

L.O. CONSOLE \_\_\_\_\_ S.O. CONSOLE \_\_\_\_\_

MAX. FOR MAINTENANCE (IDENTIFY) \_\_\_\_\_

TOTAL SHIPPING WEIGHT \_\_\_\_\_

**SPACE REQUIREMENTS (mm):**

COMPLETE UNIT	L _____	W _____	H _____
L.O. CONSOLE	L _____	W _____	H _____
S.O. CONSOLE:	L _____	W _____	H _____

**MISCELLANEOUS:**

RECOMMEND STRAIGHT RUN OF PIPE DIA. BEFORE SUCTION

VENDOR'S REVIEW & COMMENTS ON PURCHASER'S PIPING & FOUNDATION (5.1.16)

VENDOR REPRESENTATIVE OBSERVATION AT THE SITE (5.1.17)

OPTICAL ALIGNMENT FLATS REQUIRED ON COMPRESSOR, GEAR & DRIVER

LATERAL ANALYSIS & REPORT REQUIRED (5.7.1.4)

TORSIONAL ANALYSIS REPORT REQUIRED (5.7.2.1)

CASING MOUNTED TORSIONAL SHAFT VIBRATION PICKUP

COORDINATION MEETING (8.1.3)

**30 SHOP INSPECTION AND TESTS: (7.1)**

	REQ'D	WITNESS	OBSERVE
31 SHOP INSPECTION (7.1.5)	<input type="checkbox"/>	<input type="checkbox"/>	<input type="checkbox"/>
32 HYDROSTATIC (7.3.2)	<input type="checkbox"/>	<input type="checkbox"/>	<input type="checkbox"/>
33 HELIUM LEAK (7.3.4.6)	<input type="checkbox"/>	<input type="checkbox"/>	<input type="checkbox"/>
34 MECHANICAL RUN (7.3.3)	<input type="checkbox"/>	<input type="checkbox"/>	<input type="checkbox"/>
35 MECHANICAL RUN SPARE ROTORS (7.3.3.4.2)	<input type="checkbox"/>	<input type="checkbox"/>	<input type="checkbox"/>
36 CASING LEAK TEST (7.3.3.4.3)	<input type="checkbox"/>	<input type="checkbox"/>	<input type="checkbox"/>
37 PERFORMANCE TEST (GAS) (AIR) (7.3.4.1)	<input type="checkbox"/>	<input type="checkbox"/>	<input type="checkbox"/>
38 COMPLETE UNIT TEST (7.3.4.2)	<input type="checkbox"/>	<input type="checkbox"/>	<input type="checkbox"/>
39 USE SHOP LUBE & SEAL SYSTEM	<input type="checkbox"/>	<input type="checkbox"/>	<input type="checkbox"/>
40 USE JOB LUBE & SEAL SYSTEM (7.3.4.8)	<input type="checkbox"/>	<input type="checkbox"/>	<input type="checkbox"/>
41 USE SHOP VIBRATION PROBES, ETC.	<input type="checkbox"/>	<input type="checkbox"/>	<input type="checkbox"/>
42 USE JOB VIB. & AXIAL DISP. PROBES	<input type="checkbox"/>	<input type="checkbox"/>	<input type="checkbox"/>
43 USE JOB SEISMIC TRANSDUCERS	<input type="checkbox"/>	<input type="checkbox"/>	<input type="checkbox"/>
44 USE JOB MONITORING EQUIPMENT	<input type="checkbox"/>	<input type="checkbox"/>	<input type="checkbox"/>
45 PRESSURE COMP. TO FULL OPER. PRESSURE	<input type="checkbox"/>	<input type="checkbox"/>	<input type="checkbox"/>
46 DISASSEMBLE-REASSEMBLE COMP.	<input type="checkbox"/>	<input type="checkbox"/>	<input type="checkbox"/>
47 AFTER TEST (7.3.4.9)	<input type="checkbox"/>	<input type="checkbox"/>	<input type="checkbox"/>
48 SOUND-LEVEL TEST (7.3.4.4)	<input type="checkbox"/>	<input type="checkbox"/>	<input type="checkbox"/>
49 TANDEM (7.3.4.4)	<input type="checkbox"/>	<input type="checkbox"/>	<input type="checkbox"/>
50 AUX. EQUIPMENT (7.3.4.8)	<input type="checkbox"/>	<input type="checkbox"/>	<input type="checkbox"/>
51 FULL-LOAD TEST (7.3.4.10)	<input type="checkbox"/>	<input type="checkbox"/>	<input type="checkbox"/>
52 RESIDUAL UNBALANCE CHECK (5.7.3.5)	<input type="checkbox"/>	<input type="checkbox"/>	<input type="checkbox"/>
53			

**INLET & DISCHARGE DEVICES:**

HIGH EFFICIENCY INLET SEPARATOR REQUIRED (6.8.2)

INLET AIR FILTER DP INDICATION TYPE (6.7.3) \_\_\_\_\_

PULSATION SUPPRESSORS FURNISHED BY \_\_\_\_\_

SPARE PARTS TO BE SUPPLIED (8.2.3F)

ROTOR ASSEMBLY

SEALS  GASKETS, O-RINGS

START-UP/COMMISSIONING

2 YEARS SUPPLY

OTHER: \_\_\_\_\_

**REMARKS:** \_\_\_\_\_

\_\_\_\_\_

\_\_\_\_\_

\_\_\_\_\_

# ROTARY-TYPE POSITIVE- DISPLACEMENT COMPRESSOR DATA SHEET SI UNITS

JOB NO. \_\_\_\_\_ ITEM NO. \_\_\_\_\_  
 REVISION NO. \_\_\_\_\_ DATE \_\_\_\_\_  
 PAGE 6 OF 9 BY \_\_\_\_\_

VENDOR MUST FURNISH ALL PERTINENT DATA FOR THIS SPECIFICATION SHEET BEFORE RETURNING.

ITEM NO. \_\_\_\_\_ SERVICE \_\_\_\_\_ JOB NO. \_\_\_\_\_  
 MANUFACTURER \_\_\_\_\_

<p>1 <b>REFERENCE SPECIFICATIONS: (6.4.1.2)</b></p> <p>2 API 614    <input type="radio"/> YES    <input type="radio"/> NO</p> <p>3 _____</p> <p>4 _____</p> <p>5 _____</p> <p>6 _____</p> <p>7 _____</p>	<p><b>APPLICABLE SPECIFICATIONS:</b>    <input type="radio"/> IEC    <input type="radio"/> NEMA</p> <p><b>AREA CLASSIFICATION:</b></p> <p><input type="radio"/> ZONE _____ GROUP _____ CLASS _____</p> <p><input type="radio"/> AREA: CL. _____ GR. _____ DIV. _____ <input type="radio"/> NON-HAZARDOUS</p> <p><b>MOTOR CONTROL &amp; INSTRUMENT VOLTAGE:</b></p> <p>VOLTS _____ PHASE _____ CYCLES _____</p> <p><b>ALARM &amp; SHUTDOWN VOLTAGE:</b></p> <p>VOLTS _____ PHASE _____ CYCLES OR _____ DC</p>
--	--

8 **LOCAL CONTROL PANEL: (6.4.3)**

9 FURNISHED BY:     VENDOR     PURCHASER     OTHERS \_\_\_\_\_

10  FREE STANDING     WEATHERPROOF     TOTALLY ENCLOSED     EXTRA CUTOUTS

11  VIBRATION ISOLATORS     STRIP HEATERS     PURGE CONNECTIONS

12  ANNUNCIATOR: FURNISHED BY:     VENDOR     PURCHASER     OTHERS \_\_\_\_\_

13 ANNUNCIATOR LOCATED ON     LOCAL PANEL     MAIN CONTROL BOARD

14  CUSTOMER CONNECTIONS BROUGHT OUT TO TERMINAL BOXES BY VENDOR

15 **INSTRUMENT SUPPLIERS:**

16 <input type="radio"/> PRESSURE GAUGES:	MFR. _____	SIZE & TYPE: _____
17 <input type="radio"/> TEMPERATURE GAUGES:	MFR. _____	SIZE & TYPE: _____
18 <input type="radio"/> LEVEL GAUGES:	MFR. _____	SIZE & TYPE: _____
19 <input type="radio"/> DIFF. PRESSURE GAUGES:	MFR. _____	SIZE & TYPE: _____
20 <input type="radio"/> PRESSURE SWITCHES:	MFR. _____	SIZE & TYPE: _____
21 <input type="radio"/> DIFF. PRESSURE SWITCHES:	MFR. _____	SIZE & TYPE: _____
22 <input type="radio"/> TEMPERATURE SWITCHES:	MFR. _____	SIZE & TYPE: _____
23 <input type="radio"/> LEVEL SWITCHES:	MFR. _____	SIZE & TYPE: _____
24 <input type="radio"/> CONTROL VALVES:	MFR. _____	SIZE & TYPE: _____
25 <input type="radio"/> PRESSURE RELIEF VALVES: (6.4.4.6)	MFR. _____	SIZE & TYPE: _____
26 <input type="radio"/> THERMAL RELIEF VALVES: (6.4.4.6.4)	MFR. _____	SIZE & TYPE: _____
27 <input type="radio"/> FLOW INDICATORS: (6.4.4.9)	MFR. _____	SIZE & TYPE: _____
28 <input type="radio"/> GAS FLOW INDICATOR:	MFR. _____	SIZE & TYPE: _____
29 <input type="radio"/> VIBRATION EQUIPMENT:	MFR. _____	SIZE & TYPE: _____
30 <input type="radio"/> TACHOMETER: (6.4.4.2)	MFR. _____	RANGE & TYPE: _____
31 <input type="radio"/> SOLENOID VALVES	MFR. _____	SIZE & TYPE: _____
32 <input type="radio"/> ANNUNCIATOR: (6.4.5.9)	MFR. _____	MODEL & NO. POINTS _____
33 <input type="radio"/> DEPRESSURIZATION VALVE (6.4.4.7)	MFR. _____	SIZE & TYPE: _____
34 <input type="radio"/> _____	MFR. _____	SIZE & TYPE: _____

35 NOTE:     SUPPLIED BY VENDOR     SUPPLIED BY PURCHASER

36 PRESSURE GAUGE REQUIREMENTS	LOCALLY		LOCAL		FUNCTION	LOCALLY		LOCAL	
	MOUNTED (3.21)		PANEL (3.38)			MOUNTED (3.21)		PANEL (3.38)	
37 LUBE OIL PUMP DISCHARGE	<input type="checkbox"/>	<input type="radio"/>	<input type="checkbox"/>	<input type="radio"/>	GOV. CONTROL OIL	<input type="checkbox"/>	<input type="radio"/>	<input type="checkbox"/>	<input type="radio"/>
38 LUBE OIL FILTER Δ P	<input type="checkbox"/>	<input type="radio"/>	<input type="checkbox"/>	<input type="radio"/>	GOV. CONTROL OIL Δ P	<input type="checkbox"/>	<input type="radio"/>	<input type="checkbox"/>	<input type="radio"/>
39 LUBE OIL SUPPLY	<input type="checkbox"/>	<input type="radio"/>	<input type="checkbox"/>	<input type="radio"/>	MAIN STEAM IN	<input type="checkbox"/>	<input type="radio"/>	<input type="checkbox"/>	<input type="radio"/>
40 SEAL OIL PUMP DISCHARGE	<input type="checkbox"/>	<input type="radio"/>	<input type="checkbox"/>	<input type="radio"/>	1ST STAGE STEAM	<input type="checkbox"/>	<input type="radio"/>	<input type="checkbox"/>	<input type="radio"/>
41 SEAL OIL FILTER Δ P	<input type="checkbox"/>	<input type="radio"/>	<input type="checkbox"/>	<input type="radio"/>	STEAM CHEST	<input type="checkbox"/>	<input type="radio"/>	<input type="checkbox"/>	<input type="radio"/>
42 SEAL OIL SUPPLY (EACH LEVEL)	<input type="checkbox"/>	<input type="radio"/>	<input type="checkbox"/>	<input type="radio"/>	EXHAUST STEAM	<input type="checkbox"/>	<input type="radio"/>	<input type="checkbox"/>	<input type="radio"/>
43 SEAL OIL DIFFERENTIAL	<input type="checkbox"/>	<input type="radio"/>	<input type="checkbox"/>	<input type="radio"/>	EXTRACTION STEAM	<input type="checkbox"/>	<input type="radio"/>	<input type="checkbox"/>	<input type="radio"/>
44 REFERENCE GAS	<input type="checkbox"/>	<input type="radio"/>	<input type="checkbox"/>	<input type="radio"/>	STEAM EJECTOR	<input type="checkbox"/>	<input type="radio"/>	<input type="checkbox"/>	<input type="radio"/>
45 BALANCE LINE	<input type="checkbox"/>	<input type="radio"/>	<input type="checkbox"/>	<input type="radio"/>	COMPRESSOR SUCTION	<input type="checkbox"/>	<input type="radio"/>	<input type="checkbox"/>	<input type="radio"/>
46 SEAL EDUCTOR	<input type="checkbox"/>	<input type="radio"/>	<input type="checkbox"/>	<input type="radio"/>	COMPRESSOR DISCHARGE	<input type="checkbox"/>	<input type="radio"/>	<input type="checkbox"/>	<input type="radio"/>
47 BUFFER SEAL	<input type="checkbox"/>	<input type="radio"/>	<input type="checkbox"/>	<input type="radio"/>	_____	<input type="checkbox"/>	<input type="radio"/>	<input type="checkbox"/>	<input type="radio"/>
48 <b>OIL/GAS COALESCING FILTER D P</b>	<input type="checkbox"/>	<input type="radio"/>	<input type="checkbox"/>	<input type="radio"/>	_____	<input type="checkbox"/>	<input type="radio"/>	<input type="checkbox"/>	<input type="radio"/>
49 _____	<input type="checkbox"/>	<input type="radio"/>	<input type="checkbox"/>	<input type="radio"/>	_____	<input type="checkbox"/>	<input type="radio"/>	<input type="checkbox"/>	<input type="radio"/>

**ROTARY-TYPE POSITIVE-  
DISPLACEMENT COMPRESSOR  
DATA SHEET  
SI UNITS**

JOB NO. \_\_\_\_\_ ITEM NO. \_\_\_\_\_  
 REVISION NO. \_\_\_\_\_ DATE \_\_\_\_\_  
 PAGE 7 OF 9 BY \_\_\_\_\_

VENDOR MUST FURNISH ALL PERTINENT DATA FOR THIS SPECIFICATION SHEET BEFORE RETURNING.  
 ITEM NO. \_\_\_\_\_ SERVICE \_\_\_\_\_ JOB NO. \_\_\_\_\_  
 MANUFACTURER \_\_\_\_\_

1	TEMPERATURE GAUGE REQUIREMENTS:			2	3	4	5	6	7	8	9	10	
	LOCALLY MOUNTED (3.21)	LOCAL PANEL (3.28)	FUNCTION	LOCALLY MOUNTED (3.21)	LOCAL PANEL (3.28)	FUNCTION	LOCALLY MOUNTED (3.21)	LOCAL PANEL (3.28)	LOCALLY MOUNTED (3.21)	LOCAL PANEL (3.28)	FUNCTION	LOCALLY MOUNTED (3.21)	LOCAL PANEL (3.28)
	<input type="checkbox"/>	<input type="checkbox"/>	LUBE OIL DISCHARGE FROM EA.	<input type="checkbox"/>	<input type="checkbox"/>	COOLER OIL INLET & OUTLET	<input type="checkbox"/>	<input type="checkbox"/>	<input type="checkbox"/>	<input type="checkbox"/>	SEAL OIL OUTLET	<input type="checkbox"/>	<input type="checkbox"/>
	<input type="checkbox"/>	<input type="checkbox"/>	COMPR. JOURNAL BEARING	<input type="checkbox"/>	<input type="checkbox"/>	COMPRESSOR SUCTION	<input type="checkbox"/>	<input type="checkbox"/>	<input type="checkbox"/>	<input type="checkbox"/>	COMPRESSOR DISCHARGE	<input type="checkbox"/>	<input type="checkbox"/>
	<input type="checkbox"/>	<input type="checkbox"/>	DRIVER JOURNAL BEARING	<input type="checkbox"/>	<input type="checkbox"/>	LUBE OIL RESERVOIR	<input type="checkbox"/>	<input type="checkbox"/>	<input type="checkbox"/>	<input type="checkbox"/>	<b>LUBE OIL SUPPLY</b>	<input type="checkbox"/>	<input type="checkbox"/>
	<input type="checkbox"/>	<input type="checkbox"/>	GEAR JOURNAL BEARING	<input type="checkbox"/>	<input type="checkbox"/>		<input type="checkbox"/>	<input type="checkbox"/>	<input type="checkbox"/>	<input type="checkbox"/>		<input type="checkbox"/>	<input type="checkbox"/>
	<input type="checkbox"/>	<input type="checkbox"/>	COMPRESSOR THRUST BEARING	<input type="checkbox"/>	<input type="checkbox"/>		<input type="checkbox"/>	<input type="checkbox"/>	<input type="checkbox"/>	<input type="checkbox"/>		<input type="checkbox"/>	<input type="checkbox"/>
	<input type="checkbox"/>	<input type="checkbox"/>	DRIVER THRUST BEARING	<input type="checkbox"/>	<input type="checkbox"/>		<input type="checkbox"/>	<input type="checkbox"/>	<input type="checkbox"/>	<input type="checkbox"/>		<input type="checkbox"/>	<input type="checkbox"/>
	<input type="checkbox"/>	<input type="checkbox"/>	GEAR THRUST BEARING	<input type="checkbox"/>	<input type="checkbox"/>		<input type="checkbox"/>	<input type="checkbox"/>	<input type="checkbox"/>	<input type="checkbox"/>		<input type="checkbox"/>	<input type="checkbox"/>

- 11 **MISCELLANEOUS INSTRUMENTATION:**
- 12  DRIVER START/STOP  LOCAL PANEL  SEPARATE PANEL  MAIN BOARD
- 13  SIGHT FLOW INDICATORS, EACH JOURNAL & THRUST BEARING & EACH COUPLING OIL RETURN LINE
- 14  SIGHT FLOW INDICATORS, EACH SEAL OIL RETURN LINE
- 15  LEVEL GAUGES, LUBE AND/OR SEAL OIL RESERVOIR, S.O. DRAIN TRAPS & S.O. OVERHEAD TANK
- 16  VIBRATION AND SHAFT POSITION PROBES & PROXIMITORS
- 17  VIBRATION AND SHAFT POSITION READOUT EQUIPMENT
- 18  VIBRATION READOUT LOCATED ON:  LOCAL PANEL  SEPARATE PANEL  MAIN BOARD
- 19  TURBINE SPEED PICKUP DEVICES
- 20  TURBINE SPEED INDICATORS
- 21  TURBINE SPEED INDICATORS LOCATED ON:  LOCAL PANEL  MAIN BOARD
- 22  REMOTE HAND SPEED CHANGER - MOUNTED ON LOCAL PANEL
- 23  ALARM HORN & ACKNOWLEDGMENT SWITCH

24	ALARM & SHUTDOWN: (6.4.5.2)			25	26	27	28	29	30	31	32	33	34	35	36	37	38	39	40
	FUNCTION	ALARM	TRIP		FUNCTION	PRE-ALARM	TRIP												
	<input type="checkbox"/> LOW LUBE OIL PRESSURE	_____	_____		<input type="checkbox"/> TURBINE VIBRATION	_____	_____												
	<input type="checkbox"/> HI LUBE OIL FILTER Δ P	_____	_____		<input type="checkbox"/> TURBINE AXIAL POSITION	_____	_____												
	<input type="checkbox"/> HI SEAL OIL FILTER Δ P	_____	_____		<input type="checkbox"/> GEAR VIBRATION	_____	_____												
	<input type="checkbox"/> LOW LUBE OIL RESERVOIR LEV.	_____	_____		<input type="checkbox"/> GEAR AXIAL POSITION	_____	_____												
	<input type="checkbox"/> LOW SEAL OIL RESERVOIR LEV.	_____	_____		<input type="checkbox"/> COMPRESSOR MOTOR SHUTDOWN	_____	_____												
	<input type="checkbox"/> HI SEAL OIL LEVEL	_____	_____		<input type="checkbox"/> TRIP & THROTTLE VALVE SHUT	_____	_____												
	<input type="checkbox"/> LOW SEAL OIL LEVEL	_____	_____		<input type="checkbox"/> HI TURB. STEAM SEAL LEAKAGE	_____	_____												
	<input type="checkbox"/> HI SEAL OIL PRESSURE	_____	_____		<input type="checkbox"/> HI COMPR. THRUST BRG. TEMP.	_____	_____												
	<input type="checkbox"/> LOW SEAL OIL PRESSURE	_____	_____		<input type="checkbox"/> <b>HI COMPR. JOURNAL BRG. TEMP.</b>	_____	_____												
	<input type="checkbox"/> AUX. SEAL OIL PUMP START	_____	_____		<input type="checkbox"/> HI DRIVER THRUST BRG. TEMP.	_____	_____												
	<input type="checkbox"/> AUX. LUBE OIL PUMP START	_____	_____		<input type="checkbox"/> <b>HI DRIVER JOURNAL BRG. TEMP.</b>	_____	_____												
	<input type="checkbox"/> HI SEAL OIL OUTLET TEMP. (COOLER)	_____	_____		<input type="checkbox"/> <b>HI GEAR THRUST BRG. TEMP.</b>	_____	_____												
	<input type="checkbox"/> HI LIQUID LEV. SUCT. SEPARATOR	_____	_____		<input type="checkbox"/> <b>HI GEAR JOURNAL BRG. TEMP.</b>	_____	_____												
	<input type="checkbox"/> COMPRESSOR HI DISCH. TEMP.	_____	_____		<input type="checkbox"/> COMPRESSOR Δ P	_____	_____												
	<input type="checkbox"/> COMPRESSOR VIBRATION	_____	_____		<input type="checkbox"/> LOW SEAL GAS PRESSURE	_____	_____												
	<input type="checkbox"/> COMPRESSOR AXIAL POSITION	_____	_____		<input type="checkbox"/> <b>HI COALESCING GAS/OIL FILTER Δ P</b>	_____	_____												
	<input type="checkbox"/> HI LUBE OIL SUPPLY TEMPERATURE	_____	_____		<input type="checkbox"/>	_____	_____												

- 41 **CONTACTS:**
- 41 ALARM CONTACTS SHALL:  OPEN  CLOSE TO SOUND ALARM AND BE NORMALLY  ENERGIZED  DE-ENERGIZED
- 42 SHUTDOWN CONTACTS SHALL:  OPEN  CLOSE TO TRIP AND BE NORMALLY  ENERGIZED  DE-ENERGIZED
- 43 **NOTE:** NORMAL CONDITION IS WHEN COMPRESSOR IS IN OPERATION.

- 44 **MISCELLANEOUS:**
- 45  INSTRUMENT TAGGING REQUIRED.
- 46  ALARM AND SHUTDOWN SWITCHES SHALL BE SEPARATE.
- 47 PURCHASERS ELECTRICAL AND INSTRUMENT CONNECTIONS WITHIN THE CONFINES OF THE BASEPLATE AND CONSOLE SHALL
- 48 BE:  BROUGHT OUT TO TERMINAL BOXES.  MADE DIRECTLY BY THE PURCHASER.
- 49 COMMENTS REGARDING INSTRUMENTATION: \_\_\_\_\_
- 50

**ROTARY-TYPE POSITIVE-  
DISPLACEMENT COMPRESSOR  
DATA SHEET  
SI UNITS**

JOB NO. \_\_\_\_\_ ITEM NO. \_\_\_\_\_  
 REVISION NO. \_\_\_\_\_ DATE \_\_\_\_\_  
 PAGE 8 OF 9 BY \_\_\_\_\_

<p>1 APPLICABLE TO:    <input type="radio"/> PROPOSAL    <input type="radio"/> PURCHASE    <input type="radio"/> AS BUILT</p> <p>2 FOR _____</p> <p>3 SITE _____</p> <p>4 SERVICE _____</p> <p>5 MANUFACTURER _____ MODEL _____</p> <p>6 NOTE:    <input type="radio"/> INDICATES INFORMATION TO BE COMPLETED BY PURCHASER    <input type="checkbox"/> BY MANUFACTURER</p> <p>7</p>	<p>UNIT _____</p> <p>DRIVEN EQUIP. _____</p> <p>NO. REQUIRED _____</p> <p>SERIAL NO. _____</p>
MOTOR DESIGN DATA	MOTOR DESIGN DATA (CONT'D)
<p>9 <b>APPLICABLE SPECIFICATIONS:</b></p> <p>10 <input type="radio"/> IEC _____    <input type="radio"/> NEMA _____</p> <p>11 <input type="radio"/> API 541 (6.1.2.2) _____</p> <p>12 <input type="radio"/> _____</p> <p>13 <b>SITE DATA:</b></p> <p>14 <input type="radio"/> ZONE _____    <input type="radio"/> GROUP _____    <input type="radio"/> CLASS _____</p> <p>15 <input type="radio"/> AREA: CL. _____ GR. _____ DIV. _____    <input type="radio"/> NON-HAZARDOUS</p> <p>16 <input type="radio"/> ALT. _____ m    <input type="radio"/> AMB. TEMPS: MAX. _____ °C, MIN _____ °C</p> <p>17 UNUSUAL CONDITIONS:    <input type="radio"/> DUST    <input type="radio"/> FUMES</p> <p>18 <input type="radio"/> OTHER _____</p> <p>19 <b>DRIVE SYSTEM:</b></p> <p>20 <input type="radio"/> DIRECT CONNECTED    <input type="radio"/> GEAR    <input type="radio"/> OTHER _____</p> <p>21 <b>TYPE MOTOR:</b> (6.1.2.1)</p> <p>22 <input type="radio"/> SQUIRREL CAGE INDUCTION    <input type="radio"/> NEMA DESIGN _____</p> <p>23 <input type="radio"/> SYNCHRONOUS _____</p> <p>24 <input type="radio"/> POWER FACTOR REQD. _____</p> <p>25 EXCITATION:    <input type="radio"/> BRUSHLESS    <input type="radio"/> SLIP RING</p> <p>26 <input type="radio"/> FIELD DISCHARGE RESISTOR BY MOTOR MFR.</p> <p>27 <input type="radio"/> WOUND ROTOR INDUCTION</p> <p>28 <input type="radio"/> _____</p> <p>29 <b>ENCLOSURE:</b> (6.1.2.1.c)</p> <p>30 <input type="radio"/> TEFC</p> <p>31 <input type="radio"/> TEWAC _____    <input type="radio"/> TEIGF, USING _____ GAS</p> <p>32 <input type="radio"/> DOUBLE WALL CARBON STEEL TUBES</p> <p>33 <input type="radio"/> WATER SUPPLY: PRESS. _____ (bar) (kPa) TEMP. _____ °C</p> <p>34 <input type="radio"/> WATER ALLO<math>\Omega</math> <math>\Delta</math> P _____ (bar) (kPa) &amp; TEMP. RISE _____ °C</p> <p>35 <input type="radio"/> WATER SIDE MIN. CORR. ALLOW. _____ mm</p> <p>36 AND FOUL FACTOR _____</p> <p>37 <input type="radio"/> (AIR) (GAS) SUPPLY PRESS. _____ (bar) (kPa)</p> <p>38 <input type="radio"/> _____</p> <p>39 <input type="radio"/> WEATHER PROTECTED, TYPE _____</p> <p>40 <input type="radio"/> FORCED VENTILATED</p> <p>41 <input type="radio"/> OPEN-DRIPPROOF</p> <p>42 <input type="radio"/> OPEN</p> <p>43 <input type="radio"/> EEExe.    <input type="radio"/> EEExe</p> <p>44 <input type="radio"/> EEExd(e)    <input type="radio"/> Ex, xp / ExN</p> <p>45 <b>BASIC DATA:</b></p> <p>46 <input type="radio"/> _____ VOLTS    _____ PHASE    _____ HERTZ</p> <p>47 <input type="checkbox"/> NAMEPLATE KW _____    SERVICE FACTOR (6.1.2.1.g) _____</p> <p>48 <input type="radio"/> SYNCHRONOUS RPM _____</p> <p>49 <input type="radio"/> INSULATION: CLASS _____    TYPE _____</p> <p>50 <input type="radio"/> TEMP. RISE: _____ °C ABOVE _____ °C    BY _____</p> <p>51 _____</p> <p>52 _____</p>	<p><b>STARTING:</b> (6.2.1.1 b)</p> <p><input type="radio"/> FULL VOLTAGE    <input type="radio"/> REDUCED VOLTAGE _____ %</p> <p><input type="radio"/> LOADED    <input type="radio"/> UNLOADED</p> <p><input type="radio"/> VOLTAGE DIP _____ %</p> <p><b>VIBRATION:</b></p> <p><input type="radio"/> IEC STANDARD    <input type="radio"/> NEMA STANDARD _____</p> <p><b>NOISE:</b></p> <p><input type="radio"/> IEC STANDARD    <input type="radio"/> NEMA STANDARD _____</p> <p style="text-align: center;"><b>ACCESSORY EQUIPMENT</b></p> <p><input type="radio"/> BASEPLATE    <input type="radio"/> SOLEPLATE    <input type="radio"/> STATOR SHIFT</p> <p><input type="radio"/> MFR. STD. FANS    <input type="radio"/> NON-SPARKING FANS</p> <p><input type="radio"/> D.C. EXCITATION:</p> <p><input type="checkbox"/> KW REQD _____    <input type="radio"/> VOLTS _____</p> <p>BY:    <input type="radio"/> PURCHASER    <input type="radio"/> MANUFACTURER</p> <p>DESCRIPTION _____</p> <p><input type="radio"/> <b>ENCLOSED COLLECTOR RINGS:</b></p> <p><input type="radio"/> PURGED: MEDIUM _____ PRESS. _____ (BARG) (kPa)</p> <p><input type="radio"/> EXPLOSION-RESISTANT NON-PURGED</p> <p><input type="radio"/> FORCED VENTILATION</p> <p><input type="checkbox"/> m<sup>3</sup>/h _____    PRESS. DROP _____ mm H<sub>2</sub>O</p> <p><input type="radio"/> <b>BEARING TEMP DEVICES:</b></p> <p><input type="checkbox"/> LOCATION _____</p> <p><input type="checkbox"/> DESCRIPTION _____</p> <p><input type="checkbox"/> SET @ _____ °C FOR ALARM    _____ °C FOR SHUTDOWN</p> <p><input type="radio"/> <b>SPACE HEATERS:</b></p> <p><input type="checkbox"/> _____ KW    <input type="radio"/> _____ VOLTS    _____ PHASE    _____ HERTZ</p> <p><input type="radio"/> MAX. SHEATH TEMP. _____ °C</p> <p><b>WINDING TEMPERATURE DETECTORS:</b></p> <p><input type="radio"/> THERMISTORS:    NO./PHASE _____</p> <p>TYPE:    <input type="radio"/> POS. TEMP. COEFF.    <input type="radio"/> NEG. TEMP. COEFF.</p> <p>TEMPERATURE SWITCH:    <input type="radio"/> YES    <input type="radio"/> NO</p> <p><input type="radio"/> RESISTANCE TEMPERATURE DETECTORS: NO./PHASE _____</p> <p><input type="checkbox"/> RESISTANCE MATL. _____    <input type="checkbox"/> _____ OHMS</p> <p>SELECTOR SWITCH &amp; INDICATOR BY:    <input type="radio"/> PURCHR.    <input type="radio"/> MFR.</p> <p><input type="checkbox"/> MAX. STATOR WINDING TEMPS:</p> <p>_____ °C FOR ALARM    _____ °C FOR SHUTDOWN</p> <p><b>WINDING TEMP. DETECTOR &amp; SPACE HEATER LEADS:</b></p> <p><input type="radio"/> IN SAME CONDUIT BOX</p> <p><input type="radio"/> IN SEPARATE CONDUIT BOXES</p> <p><input type="radio"/> <b>MOTOR ARRANGED FOR DIFFERENTIAL PROTECTION:</b></p> <p><input type="radio"/> SELF-BALANCE PRIMARY CURRENT METHOD</p> <p><input type="radio"/> C.T. DESCRIPTION _____</p> <p><input type="radio"/> EXTENDED LEADS    <input type="checkbox"/> LENGTH _____ m</p> <p><input type="radio"/> <b>SURGE CAPACITORS</b></p>

# ROTARY-TYPE POSITIVE- DISPLACEMENT COMPRESSOR DATA SHEET SI UNITS

JOB NO. \_\_\_\_\_ ITEM NO. \_\_\_\_\_  
 REVISION NO. \_\_\_\_\_ DATE \_\_\_\_\_  
 PAGE 9 OF 9 BY \_\_\_\_\_

MOTOR ACCESSORY EQUIPMENT (CONT'D)	MOTOR MANUFACTURER'S DATA (CONT'D.)																														
2 <input type="radio"/> LIGHTNING ARRESTERS	BEARING: TYPE _____ LUBR. _____																														
3 <input type="radio"/> C.T. FOR AMMETER	LUBE OIL REQUIRED: _____ l/min @ _____ (bar)																														
4 <input type="radio"/> DESCRIPTION _____	TOTAL SHAFT END FLOAT _____																														
5 MAIN CONDUIT BOX SIZED FOR:	LIMIT END FLOAT TO _____																														
6 <input type="radio"/> MAIN MOTOR LEADS <input type="radio"/> TYPE; _____	MOTOR ROTOR: <input type="checkbox"/> SOLID <input type="checkbox"/> SPLIT																														
7 <input type="radio"/> INSULATED <input type="radio"/> NON-INSULATED	MOTOR HUB: <input type="checkbox"/> SOLID <input type="checkbox"/> SPLIT																														
8 <input type="radio"/> C.T.'S FOR DIFF. PROTECTION (MOUNTED BY _____)	FOR TEWAC & TEIGF MOTORS:																														
9 <input type="radio"/> SURGE CAPACITORS (MOUNTED BY _____)	COOLING WATER REQD. _____ m <sup>3</sup> /h																														
10 <input type="radio"/> LIGHTNING ARRESTERS (MOUNTED BY _____)	C.W. TEMP. RISE _____ °C PRESS. DROP _____ (bar)																														
11 <input type="radio"/> C.T. FOR AMMETER (MOUNTED BY _____)	(AIR) (GAS) REQD. _____ m <sup>3</sup> /h PRESS. MAINT. _____ mm H <sub>2</sub> O																														
12 <input type="radio"/> SPACE FOR STRESS CONES	CURVES REQD. BASED ON MTR SATURATION @ RATED																														
13 <input type="radio"/> AIR FILTERS:	VOLTAGE:																														
14 <input type="checkbox"/> MFR _____ <input type="checkbox"/> TYPE _____	<input type="radio"/> SPEED VS TORQUE (ALSO @ _____ % RATED VOLTAGE)																														
15 <input type="checkbox"/> MOTOR MANUFACTURER'S DATA	<input type="radio"/> SPEED VS. POWER FACTOR																														
16 MANUFACTURER _____	<input type="radio"/> SPEED VS CURRENT																														
17 FRAME NO. _____ FULL LOAD RPM (IND.) _____	<b>WEIGHT (kg):</b>																														
18 EFFICIENCY: F.L. _____ 3/4 L _____ 1/2 L _____	NET WEIGHT _____ SHIPPING WEIGHT _____																														
19 PWR. FACTOR (IND.): F.L. _____ 3/4 L _____ 1/2 L _____	ROTOR WEIGHT _____ MAX. ERECTION WT. _____																														
20 CURRENT (RATED VOLT.): FULL LOAD _____ LOCKED ROT. _____	MAX. MAINT. WT. (IDENTIFY) _____																														
21 LOCKED ROTOR POWER FACTOR _____	<b>DIMENSIONS (MILIMETERS):</b>																														
22 LOCKED ROTOR WITHSTAND TIME (COLD START) _____	L _____ W _____ H _____																														
23 TORQUES (N-m): FULL LOAD _____	<b>MOTOR SHOP INSPECTION AND TESTS</b>																														
24 LOCKED ROTOR _____ STARTING (SYN.) _____	<table border="1" style="width: 100%; border-collapse: collapse;"> <thead> <tr> <th style="width: 70%;"></th> <th style="width: 15%;">REQUIRED</th> <th style="width: 15%;">WITNESS</th> </tr> </thead> <tbody> <tr> <td>SHOP INSPECTION</td> <td style="text-align: center;"><input type="radio"/></td> <td style="text-align: center;"><input type="radio"/></td> </tr> <tr> <td>TESTING PER <input type="radio"/> IEC <input type="radio"/> NEMA</td> <td style="text-align: center;"><input type="radio"/></td> <td style="text-align: center;"><input type="radio"/></td> </tr> <tr> <td>MFR. STD. SHOP TESTS</td> <td style="text-align: center;"><input type="radio"/></td> <td style="text-align: center;"><input type="radio"/></td> </tr> <tr> <td>IMMERSION TEST</td> <td style="text-align: center;"><input type="radio"/></td> <td style="text-align: center;"><input type="radio"/></td> </tr> <tr> <td>SPECIAL TESTS (LIST BELOW)</td> <td style="text-align: center;"><input type="radio"/></td> <td style="text-align: center;"><input type="radio"/></td> </tr> <tr> <td>_____</td> <td style="text-align: center;"><input type="radio"/></td> <td style="text-align: center;"><input type="radio"/></td> </tr> <tr> <td>_____</td> <td style="text-align: center;"><input type="radio"/></td> <td style="text-align: center;"><input type="radio"/></td> </tr> <tr> <td>_____</td> <td style="text-align: center;"><input type="radio"/></td> <td style="text-align: center;"><input type="radio"/></td> </tr> <tr> <td>_____</td> <td style="text-align: center;"><input type="radio"/></td> <td style="text-align: center;"><input type="radio"/></td> </tr> </tbody> </table>		REQUIRED	WITNESS	SHOP INSPECTION	<input type="radio"/>	<input type="radio"/>	TESTING PER <input type="radio"/> IEC <input type="radio"/> NEMA	<input type="radio"/>	<input type="radio"/>	MFR. STD. SHOP TESTS	<input type="radio"/>	<input type="radio"/>	IMMERSION TEST	<input type="radio"/>	<input type="radio"/>	SPECIAL TESTS (LIST BELOW)	<input type="radio"/>	<input type="radio"/>	_____	<input type="radio"/>	<input type="radio"/>	_____	<input type="radio"/>	<input type="radio"/>	_____	<input type="radio"/>	<input type="radio"/>	_____	<input type="radio"/>	<input type="radio"/>
	REQUIRED	WITNESS																													
SHOP INSPECTION	<input type="radio"/>	<input type="radio"/>																													
TESTING PER <input type="radio"/> IEC <input type="radio"/> NEMA	<input type="radio"/>	<input type="radio"/>																													
MFR. STD. SHOP TESTS	<input type="radio"/>	<input type="radio"/>																													
IMMERSION TEST	<input type="radio"/>	<input type="radio"/>																													
SPECIAL TESTS (LIST BELOW)	<input type="radio"/>	<input type="radio"/>																													
_____	<input type="radio"/>	<input type="radio"/>																													
_____	<input type="radio"/>	<input type="radio"/>																													
_____	<input type="radio"/>	<input type="radio"/>																													
_____	<input type="radio"/>	<input type="radio"/>																													
25 PULL-UP (IND.) _____ PULL-IN (SYN.) _____																															
26 BREAKDOWN (IND.) _____ PULL-OUT (SYN.) _____																															
27 _____																															
28 OPEN CIRCUIT TIME CONSTANT (SEC.) _____																															
29 SYMMETRICAL CONTRIBUTION TO 30 TERMINAL FAULT:																															
30 AT 1/2 CYCLES _____ AT 5 CYCLES _____																															
31 REACTANCES: SUB-TRANSIENT (X'' <sub>d</sub> ) _____																															
32 TRANSIENT (X' <sub>d</sub> ) _____ SYNCHRONOUS (X <sub>d</sub> ) _____																															
33 A.C. STATOR RESISTANCE _____ OHMS @ _____ °C																															
34 RATED KVA _____	<b>PAINTING:</b>																														
35 KVA INRUSH @ FULL VOLT. & LOCKED ROTOR (SYN.) _____ %	<input type="radio"/> MANUFACTURER'S STANDARD																														
36 KVA @ FULL VOLTAGE & 95% SPEED _____ %	<input type="radio"/> OTHER: _____																														
37 MAX. LINE CURR. IN STATOR ON 1ST SLIP CYC. @ PULL-OUT	<b>SHIPMENT (7.4.1)</b>																														
38 (SYN.) _____	<input type="radio"/> DOMESTIC <input type="radio"/> EXPORT <input type="radio"/> EXPORT BOXING REQUIRED																														
39 ACCELERATION TIME (MTR ONLY @ RATED VOLT.) _____ SEC	<input type="radio"/> OUTDOOR STORAGE OVER 3 MONTHS																														
40 ACCEL TIME (MTR & LOAD @ 85% RATED VOLT.) _____ SEC																															
41 ROTOR/FIELD WK <sup>2</sup> @ MTR SHAFT (N-m <sup>2</sup> ) _____	<b>REMARKS:</b>																														
42 ROTATION FACING COUPLING END _____	_____																														
43 NO. OF STARTS PER HOUR _____	_____																														
44 _____	_____																														
45 FIELD DISCHARGE RESISTOR _____ OHMS	_____																														
46 RATED EXCITATION FIELD VOLTAGE _____ D.C.	_____																														
47 RESISTANCE OF EXCITATION FIELD @ 25°C _____ OHMS	_____																														
48 EXCITATION FIELD AMPS @ FULL LOAD & RATED P.F. _____	_____																														
49 EXCITATION FIELD AMPS: MAX. _____ MIN. _____	_____																														
50 EXCITATION FIELD <input type="checkbox"/> RHEOSTAT <input type="checkbox"/> FIXED RES'TR REQD.	_____																														
51 SUPPLIED BY _____	_____																														





**ANNEX B—NOMENCLATURE FOR ROTARY-TYPE  
POSITIVE-DISPLACEMENT COMPRESSORS**

(INFORMATIVE)



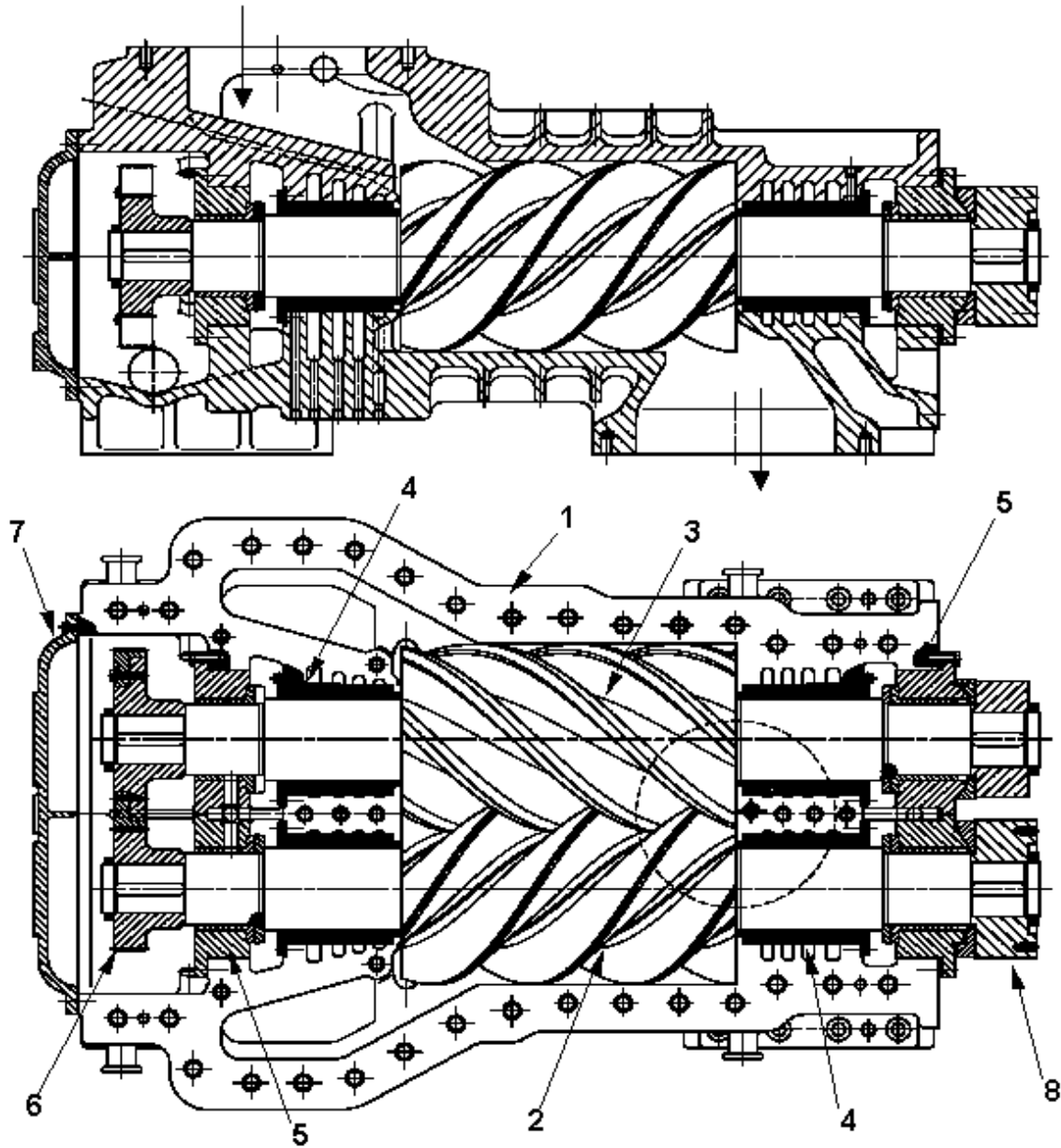

- Key:
- 1. Casing
  - 2. Male rotor
  - 3. Female rotor
  - 4. Shaft seal
  - 5. Radial/thrust bearing
  - 6. Timing gear
  - 7. End cover
  - 8. Drive shaft

Figure B-1—Dry Screw Compressor

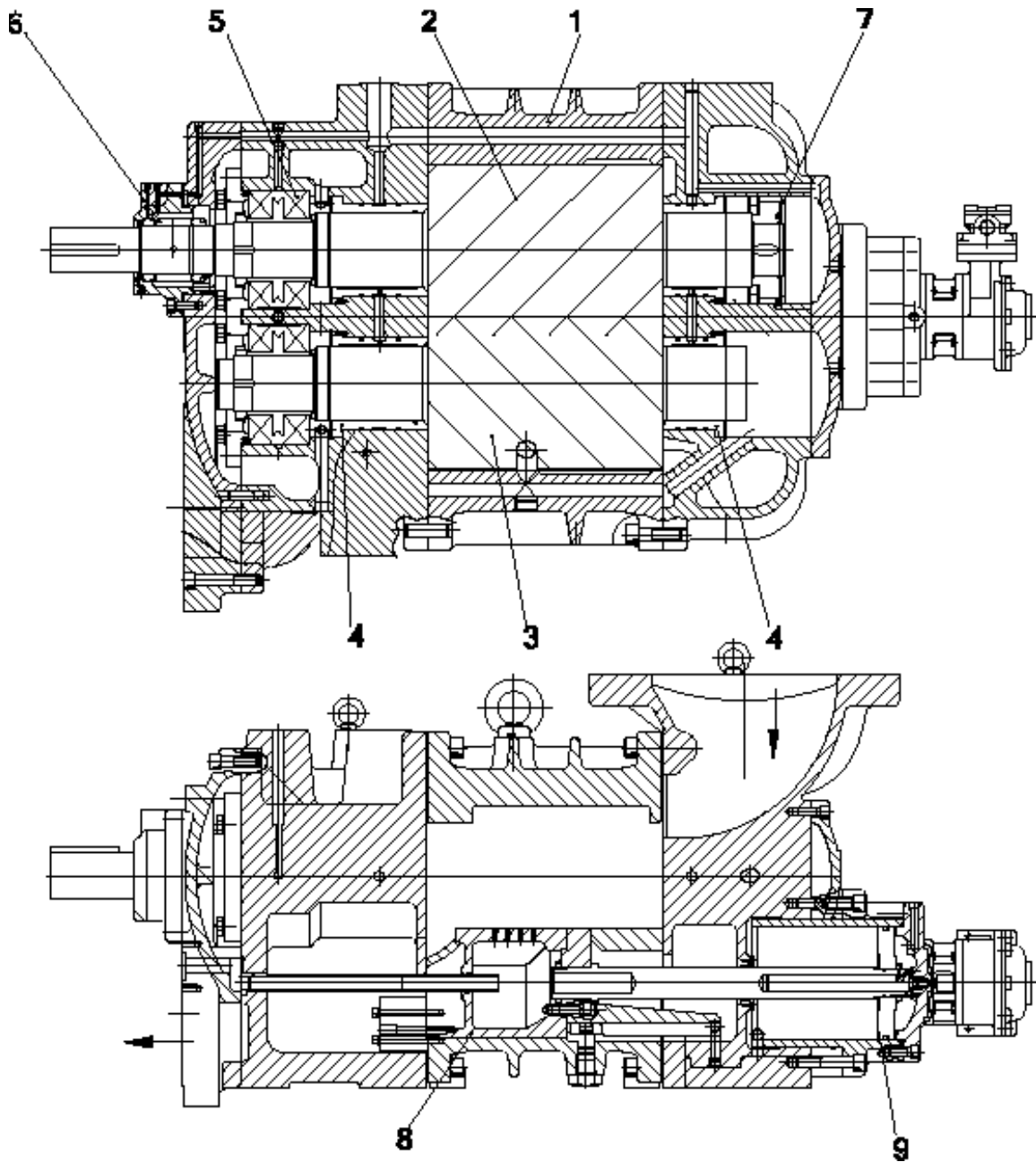

- Key:
1. Casing
  2. Male rotor
  3. Female rotor
  4. Radial bearing
  5. Thrust bearing
  6. Shaft seal
  7. Hydraulic thrust compensating piston
  8. Capacity control slide valve
  9. Double acting hydraulic piston

**Figure B-2—Flooded Screw Compressor**

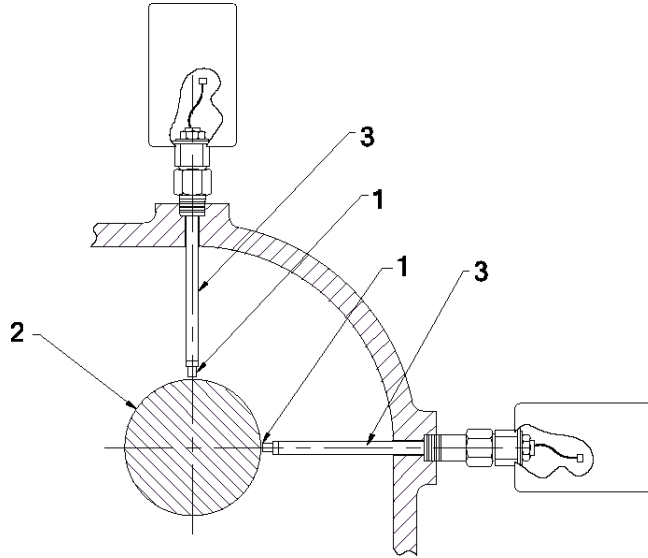

- Key:
- 1. Vibration probe
  - 2. Shaft journal
  - 3. Probe holder

**Figure B-3a—Radial Vibration Probe**

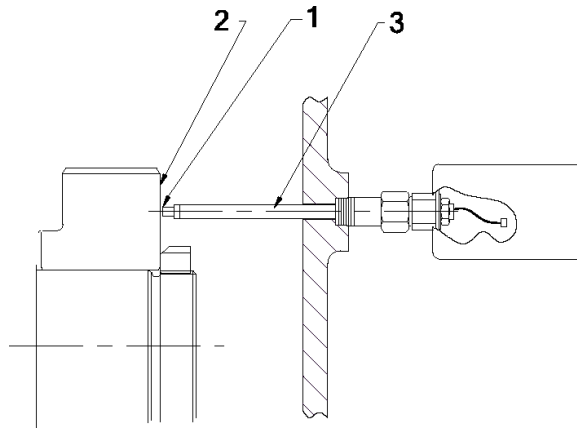

- Key:
- 1. Vibration probe
  - 2. Axial target
  - 3. Probe holder

**Figure B-3b—Axial Vibration Probe**

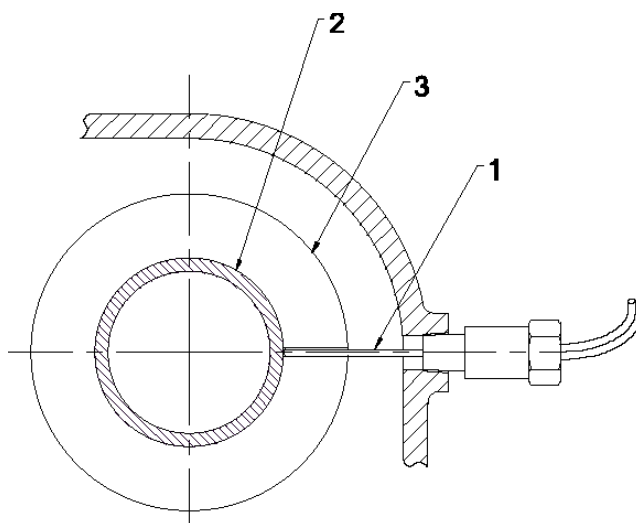

- Key:
1. Temperature probe
  2. Bearing
  3. Bearing housing

**Figure B-4a—Radial Bearing Temperature Probe**

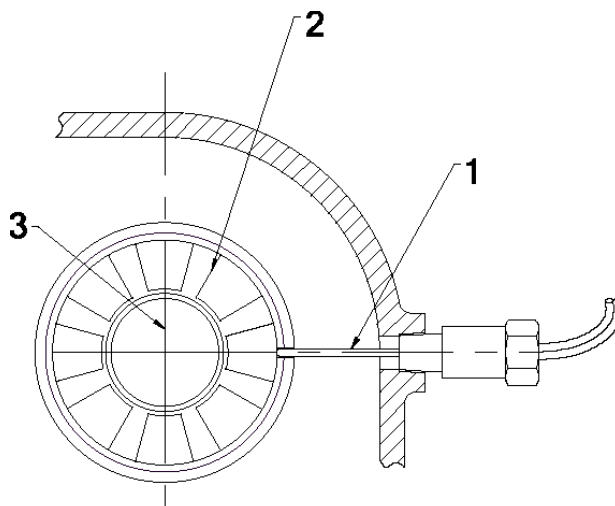

- Key:
1. Temperature probe
  2. Thrust bearing
  3. Compressor rotor centerline

Note: Alternate arrangement may include embedded RTD or thermocouple.

**Figure B-4b—Thrust Bearing Temperature Probe**

## ANNEX C—FORCES AND MOMENTS (NORMATIVE)

### C.1 General

As a minimum the compressor shall be designed to withstand external forces and moments on each nozzle as tabulated in Table C.1 and Table C.2. The vendor shall furnish the allowable forces and moments for each nozzle in tabular form.

These values of allowable forces and moments pertain to the compressor structure only. They do not pertain to the forces and moments in the connecting pipes, flanges, and flange bolting, which should not exceed the allowable stress as defined by applicable codes and regulatory bodies.

Loads may be increased by mutual agreement between the purchaser and vendor; however, it is recommended that expected operating loads be minimized.

For nozzle sizes outside the table the loads shall be agreed between the purchaser and vendor.

**Table C.1—Allowable Forces**

Nozzle size (inch NPS)	4	6	8	10	12	14	16	18	20
$F_x$ (lbf)	308	471	633	748	890	1103	1297	1460	1390
$F_y$ (lbf)	772	1181	1585	1877	2234	2764	3250	3657	3482
$F_z$ (lbf)	525	761	1018	1164	1347	1498	1684	1911	1859
$F_r$ (lbf)	983	1482	1987	2332	2756	3331	3883	4377	4185
Nozzle size (mm DN)	100	150	200	250	300	350	400	450	500
$F_x$ (N)	1368	2094	2815	3328	3960	4908	5772	6492	6182
$F_y$ (N)	3434	5253	7052	8349	9938	12294	14455	16269	15490
$F_z$ (N)	2336	3383	4527	5178	5992	6662	7492	8499	8270
$F_r$ (N)	4373	6590	8841	10373	12261	14819	17274	19469	18615

**Table C.2—Allowable Moments**

Nozzle size (inch NPS)	4	6	8	10	12	14	16	18	20
$M_x$ (ft.lbf)	1526	2031	2709	3107	3759	4597	5396	7084	6779
$M_y$ (ft.lbf)	924	1568	2091	2691	3090	4171	5001	5275	4988
$M_z$ (ft.lbf)	924	1252	1670	2076	2459	3312	4020	5275	4988
$M_r$ (ft.lbf)	2009	2855	3808	4604	5453	7036	8384	10288	9783
Nozzle size (mm DN)	100	150	200	250	300	350	400	450	500
$M_x$ (Nm)	2069	2754	3672	4212	5097	6232	7316	9605	9191
$M_y$ (Nm)	1253	2126	2836	3648	4190	5656	6781	7153	6762
$M_z$ (Nm)	1253	1698	2264	2814	3334	4491	5450	7153	6762
$M_r$ (Nm)	2724	3871	5163	6242	7393	9539	11367	13949	13264

## C.2 Equations

The X, Y and Z axes are defined in Figure C.1.

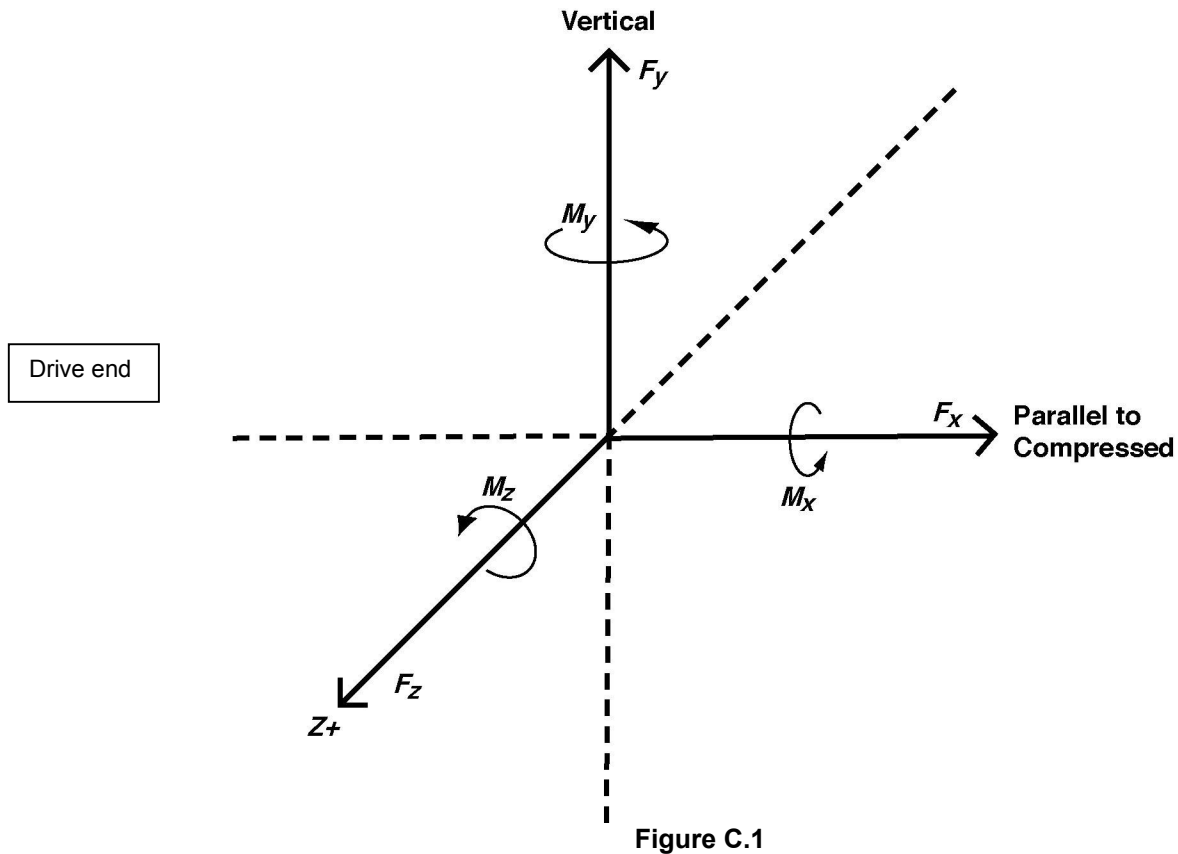

Figure C.1

The resultant force  $F_r$  is given by Equation C.1.

$$F_r = \sqrt{F_x^2 + F_y^2 + F_z^2} \quad (\text{C.1})$$

The resultant moment  $M_r$  is given by Equation C.2.

$$M_r = \sqrt{M_x^2 + M_y^2 + M_z^2} \quad (\text{C.2})$$



# ANNEX D—PROCEDURE FOR DETERMINATION OF RESIDUAL UNBALANCE

## (NORMATIVE)

### D.1 General

This annex describes the procedure to be used to determine residual unbalance in machine rotors. Although some balancing machines may be set up to read out the exact amount of unbalance, the calibration can be in error. The only sure method of determining is to test the rotor with a known amount of unbalance.

### D.2 Residual unbalance

Residual unbalance is the amount of unbalance remaining in a rotor after balancing. Unless otherwise specified, residual unbalance shall be expressed in g-mm (g-in).

### D.3 Maximum allowable residual unbalance

**D.3.1** The maximum allowable residual unbalance, per plane, shall be calculated according to 5.7.3.1 or 5.7.3.3.

**D.3.2** If the actual static weight on each journal is not known, assume that the total rotor weight is equally supported by the bearings. For example, a two-bearing rotor weighing 2,720 kg (6000 lbs) would be assumed to impose a static weight of 1,360 kg (3,000 lbs) on each journal.

### D.4 Residual unbalance check

#### D.4.1 General

**D.4.1.1** When the balancing machine readings indicate that the rotor has been balanced within the specified tolerance, a residual unbalance check shall be performed before the rotor is removed from the balancing machine.

**D.4.1.2** To check the residual unbalance, a known trial weight is attached to the rotor sequentially on each lobe, and at the same radius (i.e., same moment {g-in}). The check is run at each balance machine readout plane, and the readings in each plane are tabulated and plotted on the polar graph using the procedure specified in D.4.2.

Note: The number of weights is equal to the number of lobes on the rotor.

#### D.4.2 Procedure

**D.4.2.1** Select a trial weight and radius that will be equivalent to between one and two times the maximum allowable residual unbalance [e.g., if  $U_{max}$  is 488.4 g-mm (19.2 g-in), the trial weight should cause 488.4 to 976.8 g-mm (19.2 to 38.4 g-in) of unbalance]. This trial weight and radius must be sufficient so that the resulting plot in D.4.2.5 encompasses the origin of the polar plot.

**D.4.2.2** Starting at a convenient reference plane (i.e. ~ last heavy spot), mark off the specified six radial positions (60° increments) around the rotor. Add the trial weight near the last known heavy spot for that plane. Verify that the balance machine is responding and is within the range and graph selected for taking the residual unbalance check.

**D.4.2.3** Verify that the balancing machine is responding reasonably (i.e. no faulty sensors or displays) For example if the trial weight is added to the last known heavy spot, the first meter reading should be at least twice as much as the last reading taken before the trial weight was added. Little or no meter reading generally indicates that the rotor was not balanced to the correct tolerance, the balancing machine was not sensitive enough, or that a balancing machine fault exists (ie. a faulty pickup). Proceed, if this check is OK.

**D.4.2.4** Remove the trial weight and rotate the trial weight to the next trial position (that is, 60, 120, 180, 240, 300 and 360 degrees from the initial trial weight position for a 6-lobe rotor). Repeat the initial position as a check for repeatability on the Residual Unbalance Worksheet. All verification shall be performed using only one sensitivity range on the balance machine.

**D.4.2.5** Plot the balancing machine amplitude readout versus angular location of trial weight (NOT balancing machine phase angle) on the Residual Unbalance Worksheet and calculate the amount of residual unbalance [refer to work sheets, Figures D-3 & D-5].

Note: The maximum reading occurs when the trial weight is placed at the rotor's remaining heavy spot; the minimum reading occurs when the trial weight is placed opposite the rotor's heavy spot (light spot). The plotted readings should form an approximate circle around the origin of the polar chart. The balance machine angular location readout should approximate the location of the trial weight. The maximum deviation (highest reading) is the heavy spot (represents the plane of the residual unbalance). Blank work sheets are Figures D-1 & D-2.

**D.4.2.6** Repeat the steps described in D.4.2.1 through D.4.2.5 for each balance machine readout plane. If the specified maximum allowable residual unbalance has been exceeded in any balance machine readout plane, the rotor shall be balanced more precisely and checked again. If a balance correction is made in any balance machine readout plane, then the residual unbalance check shall be repeated in all balance machine readout planes.

# API Standard 619

Customer: \_\_\_\_\_  
 Job / Project Number: \_\_\_\_\_  
 OEM Equipment S / N: \_\_\_\_\_  
 Rotor Identification Number: \_\_\_\_\_  
 Repair Purchase Order Number: \_\_\_\_\_  
 Vendor Job Number: \_\_\_\_\_  
 Correction Plane (Left or Right)—use sketch

\_\_\_\_\_  
 \_\_\_\_\_  
 \_\_\_\_\_  
 \_\_\_\_\_  
 \_\_\_\_\_ (plane)

Balancing Speed \_\_\_\_\_ (rpm)  
 Maximum Rotor Operating Speed ( $N$ ) \_\_\_\_\_ (rpm)  
 Static Journal Weight Closest to This Correction Plane ( $W$ ) \_\_\_\_\_ (kg) \_\_\_\_\_ (lbs)  
 Trial Weight Radius ( $R$ )—the radius at which the trial weight will be placed \_\_\_\_\_ (mm) \_\_\_\_\_ (in)

Calculate Maximum Allowable Residual Unbalance ( $U_{max}$ ) per 5.7.3.1 or 5.7.3.3:

SI Units:

$U_{max} =$  \_\_\_\_\_ (g-mm)

Customary Units:

$U_{max} =$  \_\_\_\_\_ (g-in)

Calculate the trial unbalance ( $TU$ ):

Trial Unbalance ( $TU$ ) is between ( $1 \times U_{max}$ ) and ( $2 \times U_{max}$ )

SI Units:

(1 x) to (2 x) (Selected Multiplier is)  
 \_\_\_\_\_ to \_\_\_\_\_ = \_\_\_\_\_ (g-mm)  
 \_\_\_\_\_ to \_\_\_\_\_ = \_\_\_\_\_ (g-in)

Customary units:

Calculate the trial weight ( $TW$ ):

Trial Weight ( $TW$ ) =  $U_{max} = \frac{U_{max}}{R}$   
 \_\_\_\_\_ g-mm or \_\_\_\_\_ g-in = \_\_\_\_\_ (g)

Conversion Information:

1kg = 2.2046 lbs      1 ounce = 28.345 grams

Sketch the rotor configuration:

Rotor Sketch

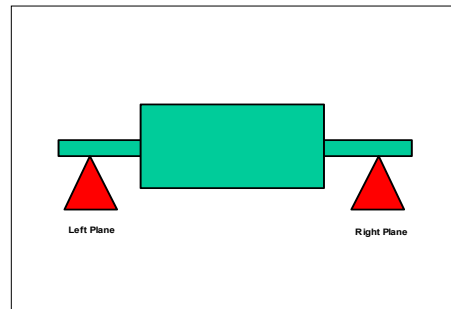

Obtain the test data and complete the table:

Test Data			
Position	Trial Weight Angular Location on Rotor (degrees)	Balancing Mach Readout	
		Amplitude (grams)	Phase Angle (degrees)
1	0		
2	60		
3	120		
4	180		
5	240		
6	300		
Repeat 1	0		

PROCEDURE:

- Step 1: Plot the balancing machine amplitude versus trial weight angular location on the polar chart (Figure D-2) such that the largest and smallest values will fit.
- Step 2: The points located on the Polar Chart should closely approximate a circle. If it does not, then it is probably that the recorded data is in error and the test should be repeated.
- Step 3: Determine the maximum and minimum balancing machine amplitude readings.
- Step 4: Using the worksheet, (Figure D-2), determine the  $Y$  and  $Z$  values required for the residual unbalance calculation.
- Step 5: Using the worksheet, (Figure D-2), calculate the residual unbalance remaining in the rotor.
- Step 6: Verify that the determined residual unbalance is equal to or less than the maximum allowable residual unbalance ( $U_{max}$ ).

HALF KEYS USED FOR ROTOR BALANCING  
 (add sketch for clarification if necessary)

Location	Weight

NOTES:

- 1) The trial weight angular location should be referenced to a keyway or some other permanent marking on the rotor. The preferred location is the location of the once-per-revolution mark (for the phase reference transducer).
- 2) The balancing machine amplitude readout for the Repeat of 1 should be the same as Position 1, indicating repeatability.
- 3) A primary source for error is not maintaining the same radius for each trial weight location.

Balanced By: \_\_\_\_\_  
 Approved By: \_\_\_\_\_

Date: \_\_\_\_\_  
 Date: \_\_\_\_\_

API Standard 619

Customer: \_\_\_\_\_  
 Job / Project Number: \_\_\_\_\_  
 OEM Equipment S / N: \_\_\_\_\_  
 Rotor Identification Number: \_\_\_\_\_  
 Repair Purchase Order Number: \_\_\_\_\_  
 Vendor Job Number: \_\_\_\_\_  
 Correction Plane (Left or Right) - use sketch \_\_\_\_\_ (plane)

RESIDUAL UNBALANCE POLAR PLOT

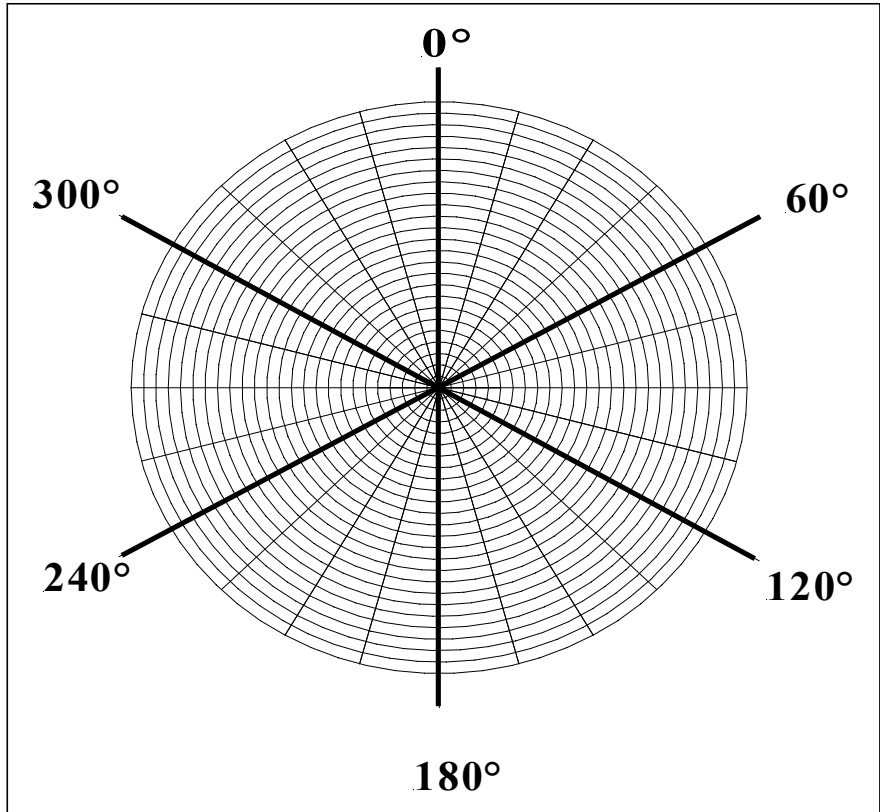

Rotor Rotation:  CCW  CW      Phase is laid out:  CCW  CW

Calculate Y and Z values:

Maximum amplitude value is: \_\_\_\_\_ grams      Minimum amplitude value is: \_\_\_\_\_ grams  
 $Y = (\text{Maximum} - \text{Minimum}) / 2$  ( \_\_\_\_\_ - \_\_\_\_\_ ) / 2 = \_\_\_\_\_  
 $Z = (\text{Maximum} + \text{Minimum}) / 2$  ( \_\_\_\_\_ + \_\_\_\_\_ ) / 2 = \_\_\_\_\_

Residual Unbalance

Left in Rotor = \_\_\_\_\_ (TU) X \_\_\_\_\_ (Y) / \_\_\_\_\_ (Z)  
 SI Units: \_\_\_\_\_ X \_\_\_\_\_ / \_\_\_\_\_ = \_\_\_\_\_ g-mm  
 Customary Units: \_\_\_\_\_ X \_\_\_\_\_ / \_\_\_\_\_ = \_\_\_\_\_ g-in

Allowable Unbalance Tolerance =  $U_{max}$  = \_\_\_\_\_ g-mm      \_\_\_\_\_ g-in

RESULT: Residual unbalance left in the rotor is equal to or less than the allowable unbalance tolerance?

As Received       Final       PASS       FAIL  
 Other: \_\_\_\_\_

Balanced By: \_\_\_\_\_ Date: \_\_\_\_\_  
 Approved By: \_\_\_\_\_ Date: \_\_\_\_\_

Figure D.2 - (Blank) Residual unbalance polar plot worksheet

# API Standard 619

Customer: ABC Refining Co.  
 Job / Project Number: 00 - 1234  
 OEM Equipment S / N: C - 1234  
 Rotor Identification Number: 1234 - C - 4320  
 Repair Purchase Order Number: PO 12345678  
 Vendor Job Number: Shop - 00 - 1234  
 Correction Plane (Left or Right)—use sketch Left (plane)

Balancing Speed 800 (rpm)  
 Maximum Rotor Operating Speed ( $N$ ) 6900 (rpm)  
 Static Journal Weight Closest to This Correction Plane ( $W$ ) 530.7 (kg) 1170 (lbs)  
 Trial Weight Radius ( $R$ )—the radius at which the trial weight will be placed 381 (mm) 15 (in)

Calculate Maximum Allowable Residual Unbalance ( $U_{max}$ ) per 5.7.3.1 or 5.7.3.3:

SI Units:  
 $U_{max} = \frac{(6350) \times (W)}{(N)} = \frac{(6350) \times 530.7}{6900} = \boxed{488.4}$  (g-mm)

Customary Units:  
 $U_{max} = \frac{(113.4) \times (W)}{(N)} = \frac{(113.4) \times 1170}{6900} = \boxed{19.2}$  (g-in)

Calculate the trial unbalance ( $TU$ ):

Trial Unbalance ( $TU$ ) is between ( $1 \times U_{max}$ ) and ( $2 \times U_{max}$ ) 1.6  
 SI Units: 488.4 to 976.8 is 781.4 (g-mm)  
 Customary units: 19.2 to 38.5 is 30.8 (g-in)

Calculate the trial weight ( $TW$ ):

Trial Weight ( $TW$ ) =  $\frac{U_{max}}{R} = \frac{781}{381}$  g-mm or  $\frac{31}{15}$  g-in = 2.1 (g)

Conversion Information:

1kg = 2.2046 lbs    1 ounce = 28.345 grams

Sketch the rotor configuration:  
Rotor Sketch

Obtain the test data and complete the table:

Test Data			
Position	Trial Weight Angular Location on Rotor (degrees)	Balancing Mach Readout	
		Amplitude (grams)	Phase Angle (degrees)
1	0	1.60	358
2	60	1.11	59
3	120	1.58	123
4	180	2.21	182
5	240	3.00	241
6	300	2.30	301
Repeat 1	0	1.58	359

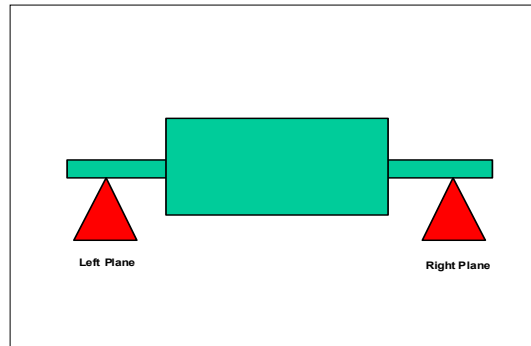

**PROCEDURE:**

- Step 1: Plot the balancing machine amplitude versus trial weight angular location on the polar chart (Figure D-2) such that the largest and smallest values will fit.
- Step 2: The points located on the Polar Chart should closely approximate a circle. If it does not, then it is probably that the recorded data is in error and the test should be repeated.
- Step 3: Determine the maximum and minimum balancing machine amplitude readings.
- Step 4: Using the worksheet, (Figure D-2), determine the  $Y$  and  $Z$  values required for the residual unbalance calculation.
- Step 5: Using the worksheet, (Figure D-2), calculate the residual unbalance remaining in the rotor.
- Step 6: Verify that the determined residual unbalance is equal to or less than the maximum allowable residual unbalance ( $U_{max}$ ).

**HALF KEYS USED FOR ROTOR BALANCING**

(add sketch for clarification if necessary)

Location	Weight

**NOTES:**

- 1) The trial weight angular location should be referenced to a keyway or some other permanent marking on the rotor. The preferred location is the location of the once-per-revolution mark (for the phase reference transducer).
- 2) The balancing machine amplitude readout for the Repeat of 1 should be the same as Position 1, indicating repeatability.
- 3) A primary source for error is not maintaining the same radius for each trial weight location.

Balanced By: CJ, TR, & RC    Date: 5/24/2000  
 Approved By: CC    Date: 5/24/2000

**Figure D.3 - Sample residual unbalance work sheet for left plane**

# API Standard 619

**Customer:**  
**Job / Project Number:**  
**OEM Equipment S / N:**  
**Rotor Identification Number:**  
**Repair Purchase Order Number:**  
**Vendor Job Number:**  
**Correction Plane (Left or Right) - use sketch**

ABC Refining Co.
00 - 1234
C - 1234
1234 - C - 4320
PO 12345678
Shop - 00 - 1234
Left (plane)

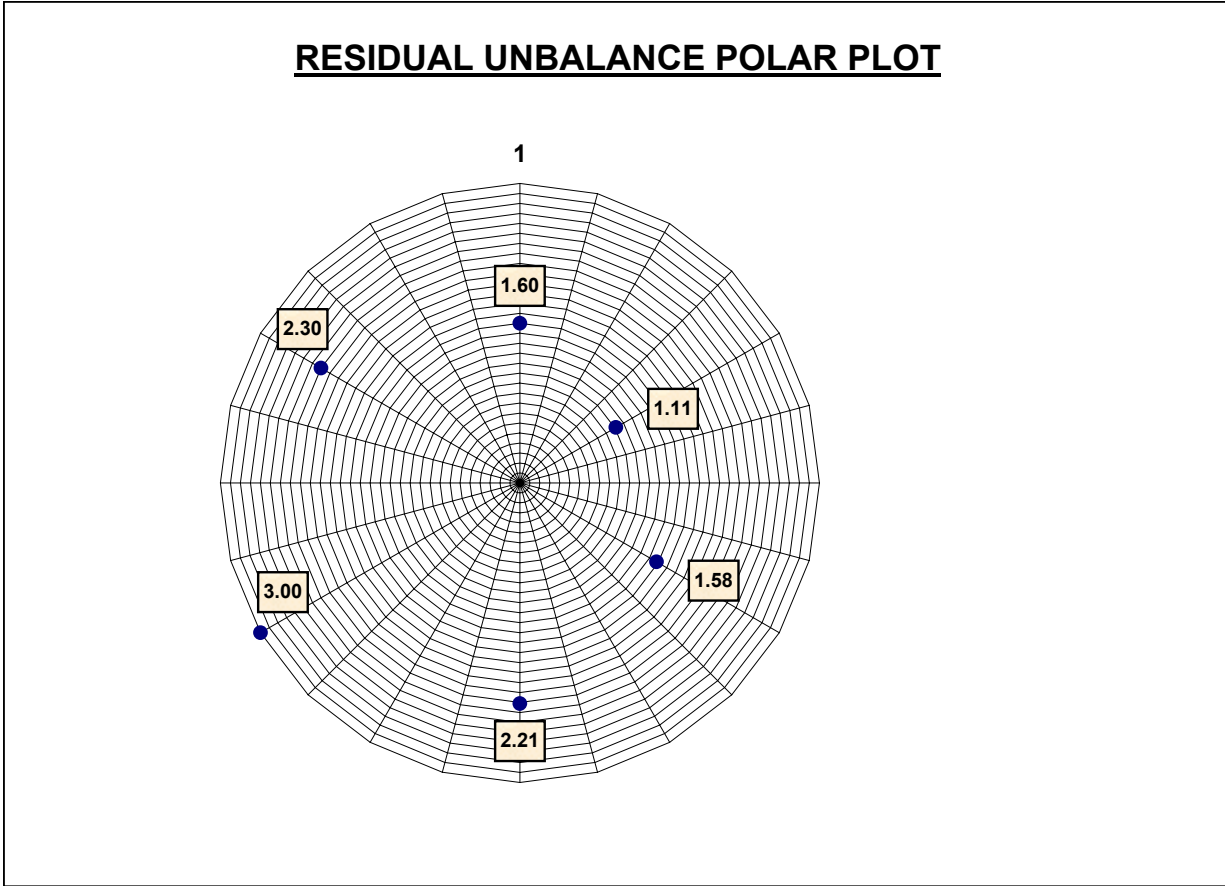

**Rotor Rotation:**  CCW       CW      **Phase is layed out:**  CCW       CW

Calculate Y and Z values:

**Maximum amplitude value is:** 3.00 grams      **Minimum amplitude value is:** 1.11 grams  
 $Y = (\text{Maximum} - \text{Minimum}) / 2 = \frac{3.00 - 1.11}{2} = 0.9$   
 $Z = (\text{Maximum} + \text{Minimum}) / 2 = \frac{3.00 + 1.11}{2} = 2.1$

**Residual Unbalance**

<b>Left in Rotor =</b>	<b>(TU)</b>	x	<b>(Y)</b>	/	<b>(Z)</b>			
<b>SI Units:</b>	781	x	0.95	/	2.06	=	359.3	g-mm
<b>Customary Units:</b>	31	x	0.95	/	2.06	=	14.1	g-in

**Allowable Unbalance Tolerance =  $U_{max}$  =** 488.4 g-mm      19.2 g-in

**RESULT:** Residual unbalance left in the rotor is equal to or less than the allowable unbalance tolerance?

PASS

As Received       Final       Other: w/o trim hardware

**Balanced By:** CJ, TR & RC      **Date:** 5/24/2000  
**Approved By:** CC      **Date:** 5/24/2000

**Figure D.4 - Sample residual unbalance polar plot work sheet for left plane**



# API Standard 619

**Customer:**  
**Job / Project Number:**  
**OEM Equipment S / N:**  
**Rotor Identification Number:**  
**Repair Purchase Order Number:**  
**Vendor Job Number:**  
**Correction Plane (Left or Right) - use sketch**

ABC Refining Co.
00 - 1234
C - 1234
1234 - C - 4320
PO 12345678
Shop - 00 - 1234
Right (plane)

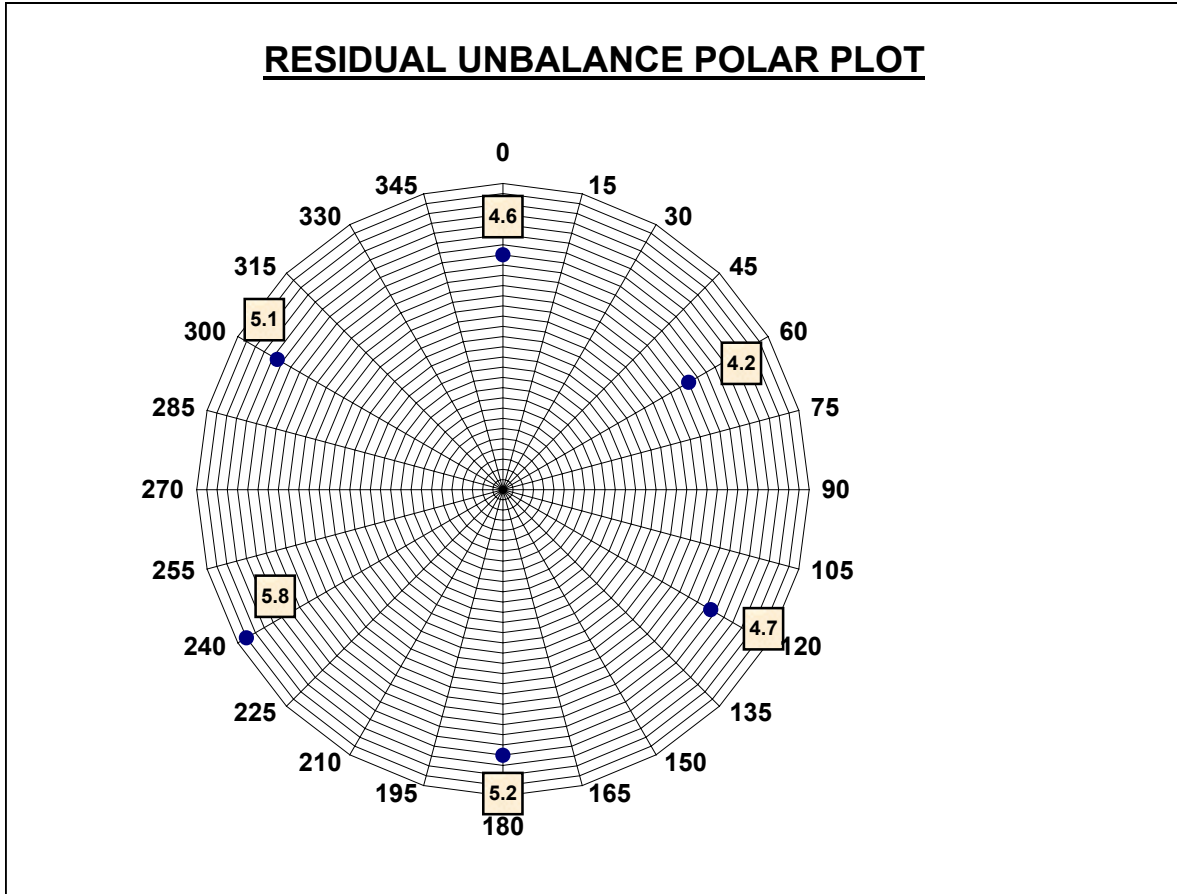

**Rotor Rotation:**       CCW       CW      **Phase is laid out:**       CCW       CW

**Calculate Y and Z values:**

**Maximum amplitude value is:** 5.80 grams      **Minimum amplitude value is:** 4.20 grams  
 $Y = (\text{Maximum} - \text{Minimum}) / 2$     5.80 - 4.20 / 2 = 0.8 grams  
 $Z = (\text{Maximum} + \text{Minimum}) / 2$     5.80 + 4.20 / 2 = 5.0 grams

**Residual Unbalance**

**Left in Rotor =**       $(TU) \times (Y) / (Z)$   
**SI Units:**      842 x 0.8 / 5 = 134.6 g-mm  
**Customary Units:**      33 x 0.8 / 5 = 5.3 g-in

**Allowable Unbalance Tolerance =  $U_{max}$**  =      525.9 g-mm      20.7 g-in

**RESULT:** Residual unbalance left in the rotor is equal to or less than the allowable unbalance tolerance?

As Received       Final       Other: w/o trim hardware

**PASS**

**Balanced By:**      CJ, TR & RC      **Date:**      5/24/2000  
**Approved By:**      CC      **Date:**      5/24/2000

**Figure D.6 - Sample Residual unbalance polar plot work sheet for right plane**



## ANNEX E—TYPICAL SCHEMATICS FOR PRESSURIZED OIL SYSTEMS FOR FLOODED SCREW COMPRESSORS

(INFORMATIVE)

**E.1** Requirements for oil systems and oil system components for flooded and dry screw compressors are detailed in Section 5.10 of this standard.

**E.2** Schematics for oil systems for dry screw compressors are covered in API Standard 614.

**E.3** Flooded Screw compressors incorporate a pressurized reservoir and Gas/Oil separator(s) in their oil system which results in unique arrangements. Some typical arrangements are presented in this annex. The systems illustrated in Figures E.1, E.2 and E.3 may be modified as necessary and as mutually agreed upon by the purchaser and the vendor to achieve a system or systems adequate for a particular application.

**E.4** Relief valves are illustrated as angle-type, the most common pattern. A straight through pattern may be used if it is adequate for the required service conditions.

Note: The oil separator's relief valve is shown on the downstream side of the coalescing filter, to minimize oil loss during system depressurization.

**E.5** The oil separator supplied on an oil-flooded screw compressor skid package is a specialized piece of equipment often employing manufacturer's proprietary internal design features. It is designed to effectively remove the oil entrained in the process gas stream prior to final process gas discharge from the package. Oil carryover rates should be agreed by the vendor and the purchaser (see 5.10.3.5.2). In some cases, multiple stages of oil separation have been employed to achieve lower acceptable oil carryover rates. Typical oil separator arrangements are shown in Figures E.4 and E.5.

Note: Oil separator orientation may be vertical or horizontal.

**E.6** Symbols used:

**Table E.1—Annex E Figure Symbols**

P	Pressure Instrument
PD	Pressure Differential Instrument
T	Temperature Instrument
L	Level Instrument
PI	Pressure Indicator
PDSLL	Pressure Differential Switch—very low
TE	Temperature Element
TSHH	Temperature Switch—very high



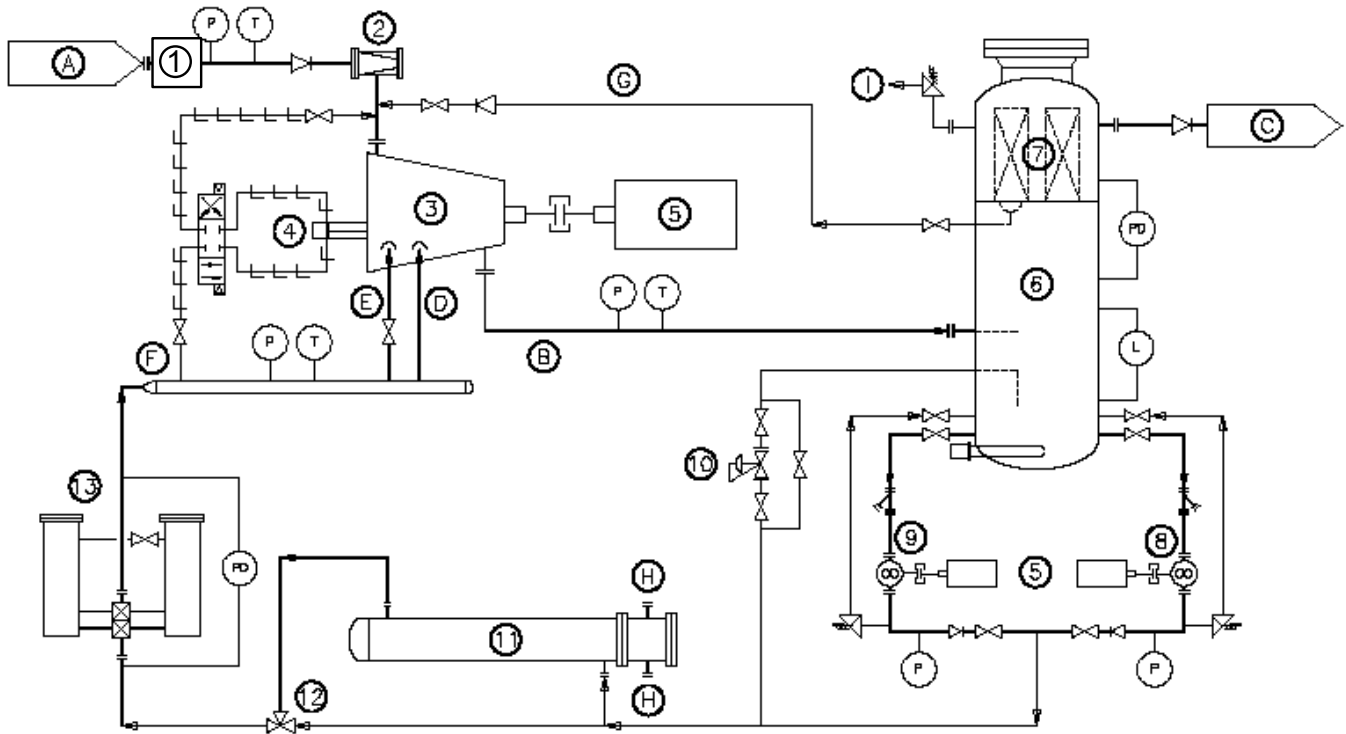

Key:

System Components:

1. Inlet scrubber
2. Strainer
3. Compressor
4. Slide valve
5. Motor
6. Oil separator
7. Coalescing element
8. Oil pump
9. Oil pump (stand-by)
10. Pressure control valve
11. Oil cooler
12. Temperature control valve
13. Oil filter

Gas/Oil/Cooling Water Stream:

- A. Suction gas
- B. Discharge gas & oil
- C. Discharge gas
- D. Lubrication & seal oil
- E. Injection oil
- F. Control oil
- G. Oil recovery
- H. Cooling water
- I. Relief valve discharge

**Figure E-2—Typical Arrangement 2**

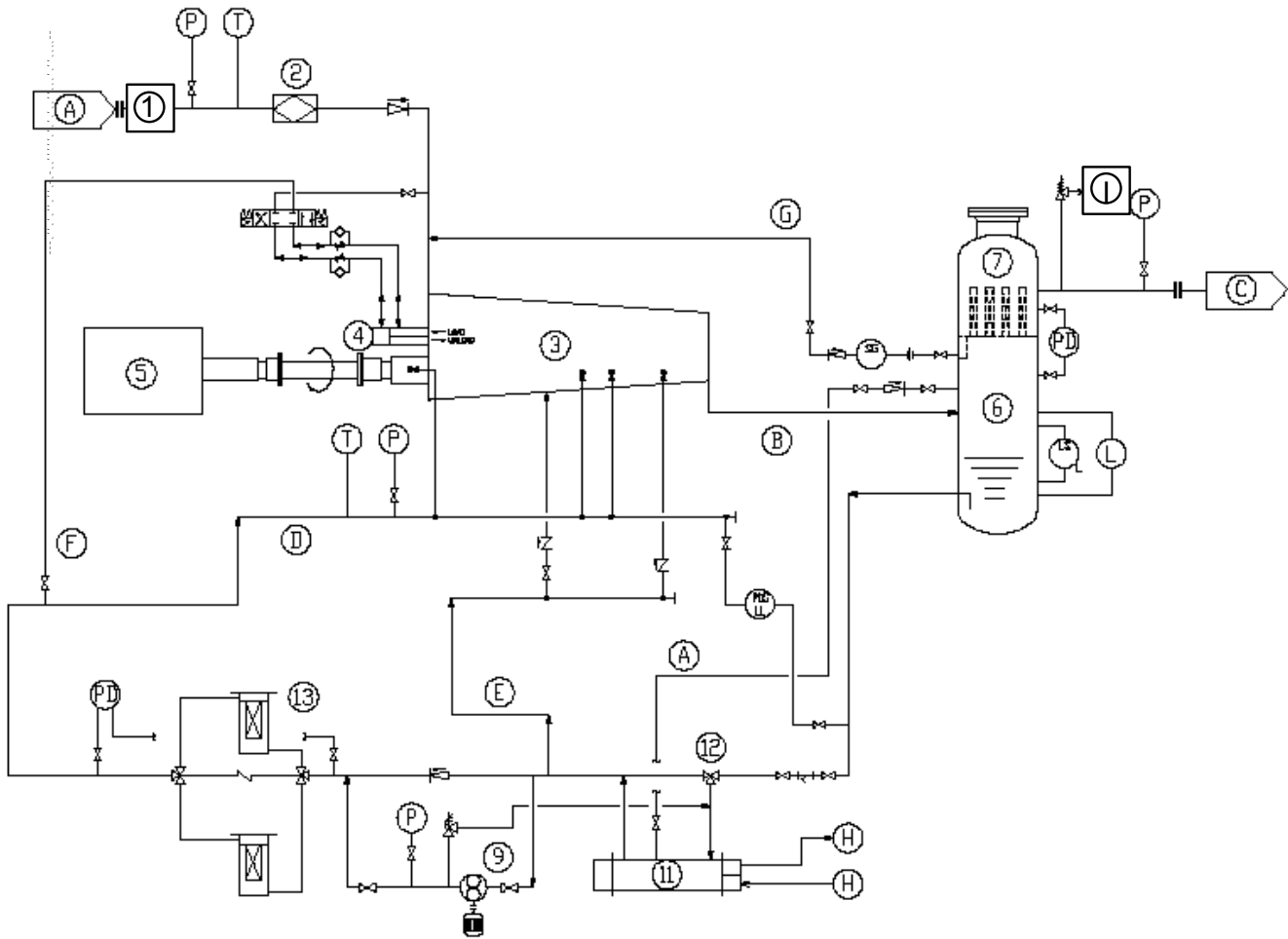

Key:

System Components:

1. Inlet scrubber
2. Strainer
3. Compressor
4. Slide valve
5. Motor
6. Oil separator
7. Coalescing element
8. Oil pump (stand-by)
9. Oil cooler
10. Temperature control valve
11. Oil filter

Gas/Oil/Cooling Water Stream:

- A. Suction gas
- B. Discharge gas & oil
- C. Discharge gas
- D. Lubrication & seal oil
- E. Injection oil
- F. Control oil
- G. Oil recovery
- H. Cooling water
- I. Relief valve discharge

**Figure E-3—Typical Arrangement 3**

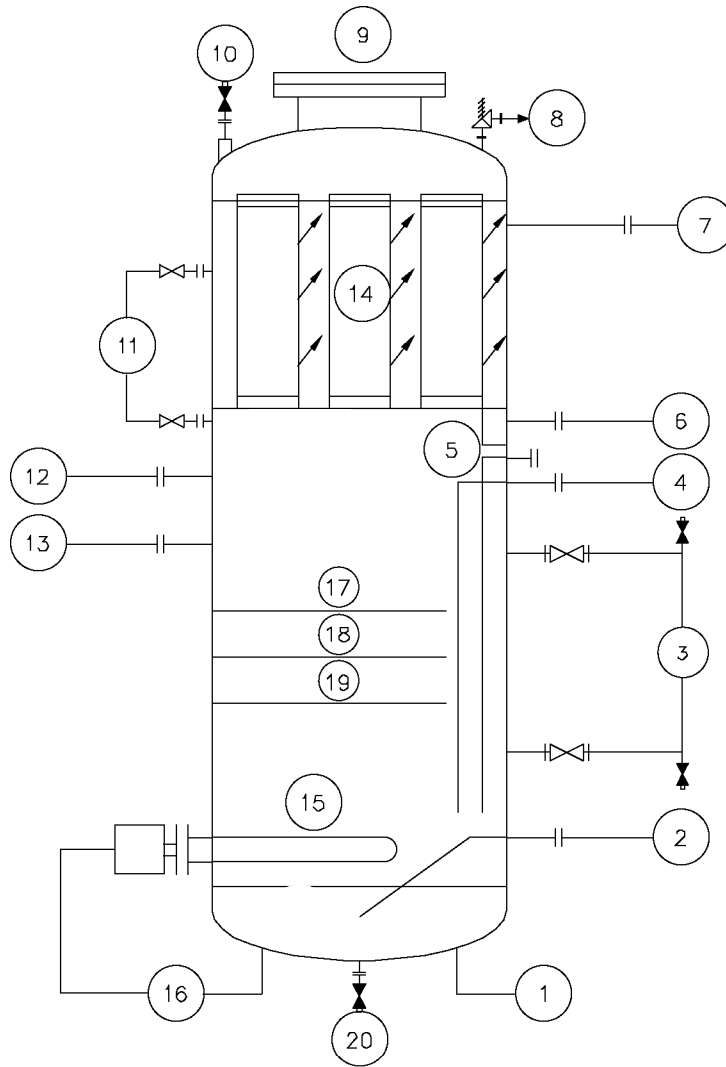

Key:

- |   |   |
|---|---|
| 1. Temperature device                     | 11. PDI: pressure differential indicator  |
| 2. Oil to oil pumps or cooler             | 12. Return from oil pump relief valve     |
| 3. Level gauge (armored)                  | 13. Gas and oil from compressor discharge |
| 4. Oil return from pressure control valve | 14. Coalescing filter element             |
| 5. Oil fill                               | 15. Electric heater                       |
| 6. Coalesced oil drain                    | 16. Temperature control device            |
| 7. Discharge gas outlet connection        | 17. Maximum level                         |
| 8. Relief valve discharge                 | 18. Normal level                          |
| 9. Inspection hatch                       | 19. Minimum level                         |
| 10. Vent                                  | 20. Drain                                 |

**Figure E-4—Oil Separator**

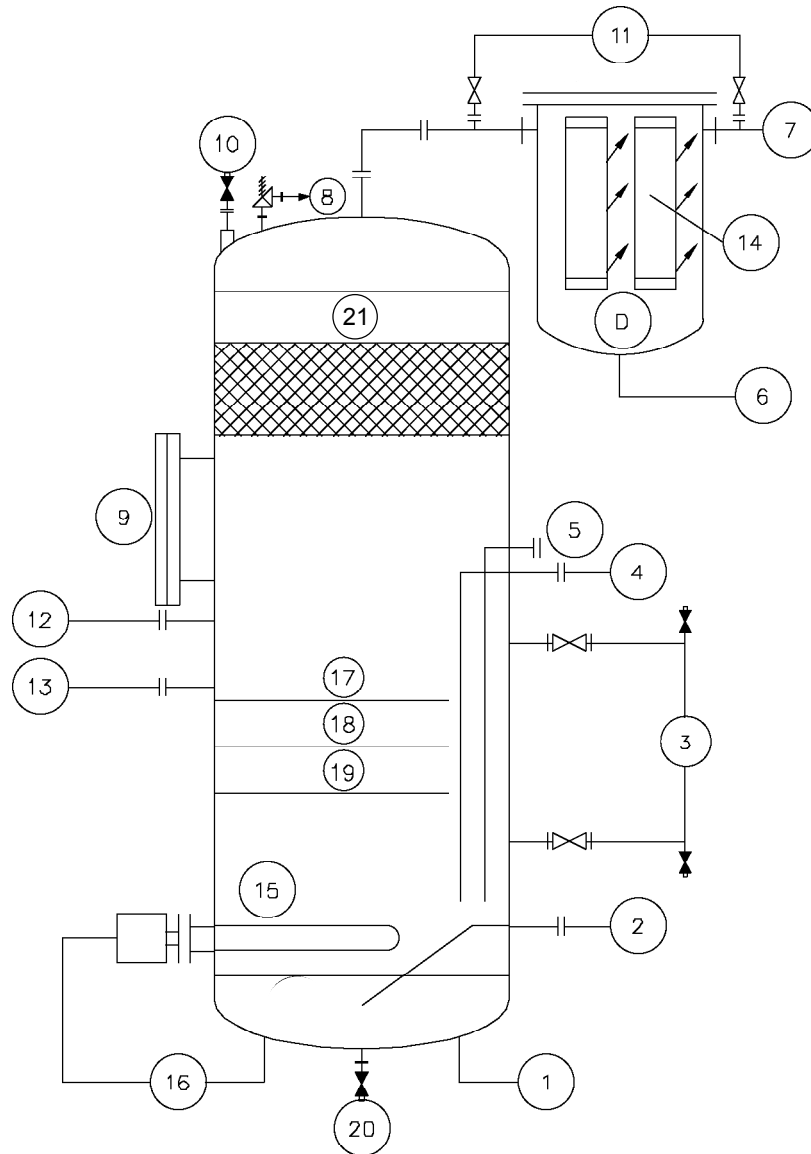

Key:

- |   |   |
|---|---|
| 1. Temperature device                     | 11. PDI: pressure differential indicator  |
| 2. Oil to oil pumps or cooler             | 12. Return from oil pump relief valve     |
| 3. Level gauge (armored)                  | 13. Gas and oil from compressor discharge |
| 4. Oil return from pressure control valve | 14. Coalescing filter element             |
| 5. Oil fill                               | 15. Electric heater                       |
| 6. Coalesced oil drain                    | 16. Temperature control device            |
| 7. Discharge gas outlet connection        | 17. Maximum level                         |
| 8. Relief valve discharge                 | 18. Normal level                          |
| 9. Inspection hatch                       | 19. Minimum level                         |
| 10. Vent                                  | 20. Drain                                 |
|   | 21. Demister pad                          |

**Figure E-5—Oil Separator**  
(with external coalescer chamber)

**ANNEX F—MATERIALS AND THEIR SPECIFICATIONS FOR  
ROTARY COMPRESSORS**

(INFORMATIVE)

.....



**Table F-1 Materials and Their Specifications for Rotary Compressors**

**CAUTION:** This table is intended as a general guide. See 5.11.1.1 and 5.11.1.2. It should not be used without a knowledgeable review of the specific services involved.

Component	Material	Specification	Material Application		Temperature Limits of Materials					
			DS = Dry Screw OF = Oil-Flooded	Form	degrees C		degrees F			
					Minimum	Maximum	Minimum	Maximum		
Casing (cast)	Gray iron	ASTM A 278 Class 40	OF	Cast	-29	260	-20	500		
	Gray iron	DIN EN 1561 GJL-250	OF& DS	Cast	-10	250	14	482		
	Gray iron	JIS G5501 FC250	OF	Cast	-29	232	-20	450		
	Gray iron	JIS G5501 FC300	OF& DS	Cast	-29	232	-20	450		
	Gray iron	JIS G5501 FC350	OF	Cast	-29	232	-20	450		
	Ductile iron	ASTM A 395, Grade 60	OF	Cast	-29	260	-20	500		
	Ductile iron	DIN EN 1563 GGG 40.3	DS	Cast	-20	300	-4	572		
	Ductile iron	DIN EN 1563 GJS-400-15	OF& DS	Cast	-10	250	14	482		
	Ductile iron	DIN EN 1563 GJS-400-18-LT	OF& DS	Cast	-20	300	-4	572		
	Steel	DIN EN 10213 GP240 GH	OF& DS	Cast	-10	300	14	572		
	Steel	DIN EN 10213 GS-21Mo5	OF	Cast	-46	343	-51	649		
	Steel	JIS G5152 SCPL1	OF	Cast	-45	350	-49	662		
	Steel	JIS G5152 SCPL11	OF& DS	Cast	-60	350	-76	662		
	Steel	JIS G5152 SCPL21	OF	Cast	-75	200	-103	392		
	Steel	JIS G5152 SCPL31	OF	Cast	-100	200	-148	392		
	Steel	JIS G5201 SCW480	OF& DS	Cast	-29	399	-20	750		
	Steel	JIS G5121 SCS13	DS	Cast	-196	350	-321	662		
	Stainless Steel	ASTM A 351 Grades CF3, CF3M, CF8, CF8M	DS	Cast	-196	343	-320	650		
	Stainless Steel	ASTM A 216 Grade WCB	DS	Cast	-28	400	-20	750		
	Stainless Steel	ASTM A 351 Grade CF3, CF3M	DS	Cast	-195	345	-319	653		
Stainless Steel	ASTM A 743 Grade CA6 - NM	DS	Cast	-195	345	-319	653			
Stainless Steel	DIN EN 10213 GX3 CrNiMo 13-4	DS	Cast	-105	300	-157	572			
Stainless Steel	DIN EN 10213 GX5CrNiMoNb19	DS	Cast	-200	300	-328	572			
Stainless Steel	JIS G5121 SCS14	DS	Cast	-196	350	-321	662			
Stainless Steel	JIS G5121 SCS5/13Cr-4Ni	DS	Cast	-196	350	-321	662			
Shaft	Ductile iron	JIS G5502 FCD700	OF	Cast	-29	350	-20	662		
	Steel	AISI 1030-1035	OF	Forged	-29	399	-20	750		
	Steel	AISI 1040-1050	OF& DS	Forged	-29	343	-20	650		
	Steel	ASTM A 350 LF2	OF	Forged	-45		-49			
	Steel	ASTM A 668 Class D - 1030 carbon steel	DS	Forged	-29	399	-20	750		
	Steel	DIN EN 10083 25 CrMo 4	DS	Forged	-10	300	14	572		
	Steel	DIN EN 10083 C45N	OF	Forged	-29	399	-20	750		

Component	Material	Specification	Material Application		Temperature Limits of Materials						
			DS = Dry Screw OF = Oil-Flooded	Form	degrees C			degrees F			
					Minimum	Maximum	Minimum	Maximum	Minimum	Maximum	
	Steel	JIS G4051 S30C	OF& DS	Forged	-10	450	14	842			
	Steel	JIS G4051 S45C	OF	Forged	-10	450	14	842			
	Steel	JIS G4051 S55C	OF	Forged	-10	450	14	842			
	Steel	JIS G4105 SCM430	DS	Forged	-30	400	-22	752			
	Steel	SAE1137	OF	Forged							
	Stainless Steel	ASTM A 473 Type 304L	DS	Forged	-196	400	-321	752			
	Stainless Steel	ASTM A 473 Type 316L	DS	Forged	-196	400	-321	752			
	Stainless Steel	ASTM A 479 Class 1 Type 410	DS	Bar	-59	345	-75	650			
	Stainless Steel	DIN EN 10088 X3CrNiMo 13-4	DS	Forged	-105	300	-157	572			
	Stainless Steel	DIN EN 10088X17CrNi16-2	DS	Forged							
	Stainless Steel	JIS G3214 SUS F 6NM / 13Cr-4Ni	DS	Forged	-105	300	-157	752			
	Stainless Steel	JIS G3214 SUS304	DS	Forged	-196	400	-321	752			
	Stainless Steel	JIS G3214 SUS316	DS	Forged	-196	400	-321	752			
	Stainless Steel	JIS G3214 SUS405	DS	Forged	-10	400	14	752			
	Ductile iron	JIS G5502 FCD600	OF	Cast	-29	260	-20	500			
	Ductile iron	JIS G5502 FCD700	OF	Cast	-29	350	-20	662			
	Steel	AISI 1030-1045	OF & DS	Forged	-29	399	-20	750			
	Steel	ASTM A 350 LF2	OF	Forged	-45	149	-49	300			
	Steel	ASTM A 668 Class D - 1030 carbon steel	DS	Forged	-29	399	-20	750			
	Steel	DIN EN 10083 25CrMo 4	DS	Forged	-10	300	14	572			
	Steel	DIN EN 10083 C45N	OF	Forged	-29	399	-20	750			
	Steel	JIS G3221 SFCM 930S	OF	Forged	-29	399	-20	750			
	Steel	JIS G4051 S30C	OF & DS	Forged	-10	450	14	842			
	Steel	JIS G4051 S45C	OF	Forged	-10	450	14	842			
	Steel	JIS G4051 S55C	OF	Forged	-10	450	14	842			
	Steel	JIS G4105 SCM430	OF	Forged	-30	400	-22	752			
	Steel	SAE1137	OF	Forged							
	Stainless Steel	ASTM A 473 TYPE 431	DS	Forged							
	Stainless Steel	ASTM A 473 Type 304L	DS	Forged	-196	400	-321	752			
	Stainless Steel	ASTM A 473 Type 316L	DS	Forged	-196	400	-321	752			
	Stainless Steel	ASTM A 479 Class 1 Type 410	DS	Bar	-59	345	-75	650			
	Stainless Steel	DIN EN 10088 X3CrNiMo 13-4	DS	Forged	-105	300	-157	572			
	Stainless Steel	JIS G3214 SUS 405	DS	Forged	-10	400	14	752			
	Stainless Steel	JIS G3214 SUS F 6NM/13Cr-4Ni	DS	Forged	-105	300	-157	572			
	Stainless Steel	JIS G3214 SUS304	DS	Forged	-196	400	-321	752			
	Stainless Steel	JIS G3214 SUS316	DS	Forged	-196	400	-321	752			

ROTARY-TYPE POSITIVE-DISPLACEMENT COMPRESSORS FOR PETROLEUM, PETROCHEMICAL, AND NATURAL GAS INDUSTRIES

Component	Material	Specification	Material Application		Temperature Limits of Materials						
			DS = Dry Screw OF = Oil-Flooded	Form	degrees C			degrees F			
					Minimum	Maximum	Minimum	Maximum			
Pulsation devices	Ductile iron	DIN EN 1563 GGG40.3	DS	Cast	-20	300	-4	572			
	Steel	ASTM A 516-60	DS	Plate							
	Steel	ASTM A 516-70 made to A593	OF & DS	Plate	-46 (1)	-	-50 (1)	-			
	Steel	ASTM A 105	OF & DS	Forged	-29		-20				
	Steel	ASTM A 106B	OF & DS	Pipe	-29		-20				
	Steel	ASTM A 516 Grade 70	DS	Plate	-46		-50				
	Steel	DIN EN 10025 S235JRG2-1	DS	Plate	-10	400	14	752			
	Steel	DIN EN 10213 GP240 GH	DS	Cast	-10	300	14	572			
	Steel	DIN EN 10216 P265 GH / HII	DS	Plate	-10	400	14	752			
	Steel	JIS G3103 SB410	OF & DS	Plate	0	350	32	662			
	Steel	JIS G3103 SB480	OF & DS	Plate	0	350	32	662			
	Steel	JIS G3106 SM400B	OF & DS	Plate	0	350	32	662			
	Steel	JIS G3115 SPV235	OF & DS	Plate	-10	350	14	662			
	Steel	JIS G3115 SPV315	OF & DS	Plate	-10	350	14	662			
	Steel	JIS G3454 STPG370-S	OF & DS	Pipe	-10	350	14	662			
	Stainless Steel	ASTM A 213 TP316L	DS	Plate							
	Stainless Steel	ASTM A 312 Type 316	DS	Pipe	-195		-320				
	Stainless Steel	ASTM A 312 Types 304 and 316	OF & DS	Pipe	-195		-320				
	Stainless Steel	ASTM A 240 - Type 316	DS	Plate	-195		-320				
	Stainless Steel	ASTM A 333 - Grade 6	DS	Pipe	-46		-50				
Stainless Steel	DIN EN 10088 X5CrNi18-10	DS	Plate	-196	400	-321	752				
Stainless Steel	DIN EN 10088 X5CrNiMo17-12-2	DS	Plate	-196	400	-321	752				
Stainless Steel	DIN EN 10088 X6CrNiMoTi17-12-2	DS	Plate	-196	400	-321	752				
Stainless Steel	DIN EN 10088 X6CrNiTi18-10	DS	Plate	-10	400	14	752				
Stainless Steel	DIN EN 10213 GX3 CrNiMo 13-4	DS	Cast	-105	300	-157	572				
Stainless Steel	JIS G4304 SUS304	OF & DS	Plate	-196	400	-321	752				
Stainless Steel	JIS G4304 SUS316	OF & DS	Plate	-196	400	-321	752				

Notes:

1. Must be impact tested for the operating temperature.
2. The operating temperature limits of the compressor may be different, but must be within the temperature limits of the materials.



**ANNEX G—TYPICAL MOUNTING PLATE ARRANGEMENTS**  
**(INFORMATIVE)**

.....

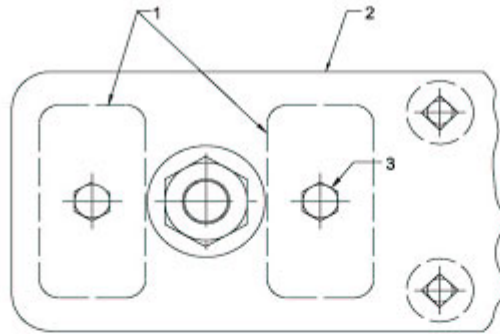

a) Top view of foundation at foundation bolt

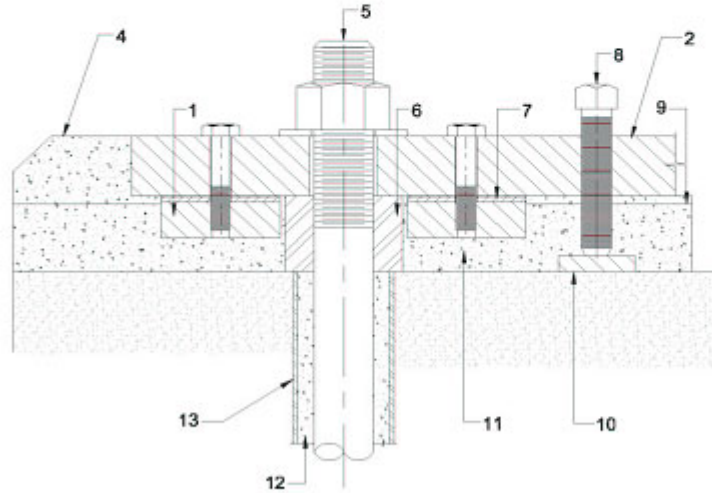

b) Cross-section of foundation at foundation bolt

Key

1. Subplate
2. Mounting plate
3. Capscrew
4. Optional full bed grout level
5. Anchor bolt
6. Anchor bolt sleeve grout seal
7. Shims
8. Leveling jackscrew
9. Grout level for shim access
10. Leveling plate
11. Epoxy grout
12. Non-bonding fill
13. Anchor bolt sleeve

**Figure G-1—Typical Mounting Plate Arrangement—Soleplate with Subplate**

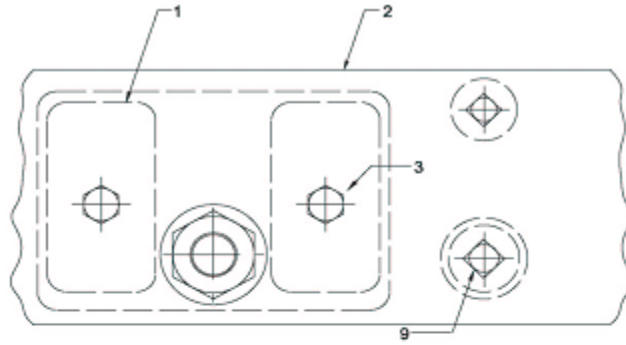

a) Top view of foundation at foundation bolt

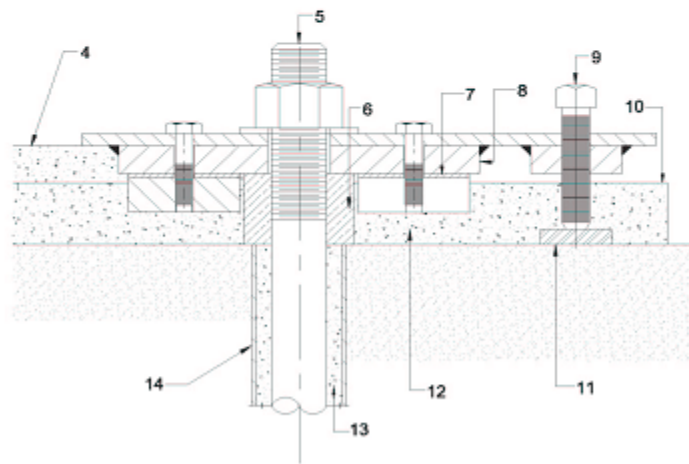

b) Cross-section of foundation at foundation bolt

Key:

1. Subplate
2. Baseplate beam
3. Capscrew
4. Optional full bed grout level
5. Anchor bolt
6. Anchor bolt sleeve grout seal
7. Shims
8. Baseplate mounting pad
9. Leveling jackscrew
10. Grout level for shim access
11. Leveling plate
12. Epoxy grout
13. Non-bonding fill
14. Anchor bolt sleeve

**Figure G-2—Typical Mounting Plate Arrangement—Baseplate with Subplate**



**ANNEX H—INSPECTOR’S CHECKLIST**  
(INFORMATIVE)



**ANNEX H—INSPECTOR'S CHECKLIST (INFORMATIVE)**

Item	Reference paragraph API 619	Date inspected	Inspected by	Status
Material Inspection	7.2.2			
Piping fabrication and installation	6.5			
Hydrostatic test	7.3.2			
Heat run	7.3.3.5			
Mechanical running test	7.3.3			
Gas leakage test	7.3.3.4.3			
Optional tests: Performance test Complete unit test Deceleration test Tandem test Gear test Helium test Sound-level test Auxiliary equipment test Post-test inspection Full-pressure/full-load/full-speed test Inspection of hub/shaft fit for hydraulically mounted couplings Spare parts test	7.3.4.1 7.3.4.2 7.3.4.3 7.3.4.4 7.3.4.5 7.3.4.6 7.3.4.7 7.3.4.8 7.3.4.9 7.3.4.10 7.3.4.11 7.3.4.12			
Additional test-as specified				
Examination of internals for cleanliness: Piping Oil reservoir Bearing housings Gear housings Coolers Filters other	7.2.3			
Nameplate and rotation arrows	5.12			

Item	Reference paragraph API 619	Date inspected	Inspected by	Status
Overall dimensions and connection locations <sup>1</sup>				
Flange dimensions and finish <sup>1</sup>				
Anchor bolt layout and size <sup>1</sup>				
Preparation for shipment				
Corrosion protection—exterior	7.4.3.1, 7.4.3.2			
Corrosion protection—interior	7.4.3.3,			
Corrosion protection—lubricated surfaces	7.4.3.4			
Closures of all openings	7.4.3.6, 7.4.3.7, 7.4.3.8			
Equipment nameplate data	5.12.4			
Equipment identification	7.4.3.10			
Piping connections identification (tagging)	7.4.4			
Additional inspections—as required				

<sup>1</sup> Check against certified drawings.

# **ANNEX I—TYPICAL VENDOR DRAWING AND DATA REQUIREMENTS**

(INFORMATIVE)





# ROTOR REPAIR VENDOR DRAWING AND DATA REQUIREMENTS

JOB NO. \_\_\_\_\_ ITEM NO. \_\_\_\_\_  
 PURCHASE ORDER NO. \_\_\_\_\_ DATE \_\_\_\_\_  
 REQUISITION NO. \_\_\_\_\_ DATE \_\_\_\_\_  
 INQUIRY NO. \_\_\_\_\_ DATE \_\_\_\_\_  
 PAGE 2 OF 2 BY \_\_\_\_\_

FOR \_\_\_\_\_ REVISION \_\_\_\_\_ DATE \_\_\_\_\_  
 SITE \_\_\_\_\_ UNIT \_\_\_\_\_  
 SERVICE \_\_\_\_\_ NO. REQUIRED \_\_\_\_\_

Proposal<sup>a</sup> Bidder shall furnish \_\_\_\_\_ copies of data for all items indicated by an X.

Review<sup>b</sup> vendor shall furnish \_\_\_\_\_ copies and \_\_\_\_\_ transparencies of drawings and data indicated.

Final<sup>b</sup> Vendor shall furnish \_\_\_\_\_ copies and \_\_\_\_\_ transparencies of drawings and data indicated.  
 Vendor shall furnish \_\_\_\_\_ operating and maintenance manuals.

**DISTRIBUTION  
RECORD**

Final—Received from vendor \_\_\_\_\_  
 Final—Due from vendor<sup>c</sup> \_\_\_\_\_  
 Review—Returned to vendor \_\_\_\_\_  
 Review—Received from vendor \_\_\_\_\_  
 Review—Due from vendor<sup>c</sup> \_\_\_\_\_

		DOCUMENT						
		34. Silencer drawings and data						
		35. Intercoolers/aftercoolers drawings and data						
		36. Nondestructive test procedures and acceptance criteria						
		37. Procedures for special or optional tests (see 7.3.4)						
		38. Installation manual						
		39. Operating and maintenance manuals						
		40. Spare parts recommendation						
		41. Engineering, fabrication and delivery schedule (progress reports)						
		42. List of drawings						
		43. Shipping list						
		44. List of special tools furnished for maintenance						
		45. Technical data manual						
		46. Material Safety Data Sheets						
		47. Preservation, packaging, and shipping procedures						
		48. Bearing babbitt strength versus temperature curves						

<sup>a</sup>Proposal drawings and data do not have to be certified or as-built.

<sup>b</sup>Purchaser should indicate in this column the time frame for submission of materials using the nomenclature below.

<sup>c</sup>This column reflects bidder's or vendor's actual distribution schedule.

**Notes:**

1. Permission to proceed with manufacture without purchaser's review of drawings (if granted) should be stated in the purchase order.
2. For a detailed explanation of drawing and data requirements, see "Description" in this Annex.

**Nomenclature:**

- \_\_\_\_\_ S—number of weeks prior to shipment.
- \_\_\_\_\_ F—number of weeks after firm order.
- \_\_\_\_\_ D—number of weeks after receipt of approved drawings.

Address for shipment of all drawings and data:

\_\_\_\_\_  
 \_\_\_\_\_  
 \_\_\_\_\_  
 \_\_\_\_\_

Vendor \_\_\_\_\_

Date \_\_\_\_\_ Vendor Reference No. \_\_\_\_\_

Signature \_\_\_\_\_

(Signature acknowledges receipt of all instructions)



## Description

- 1) Certified dimensional outline drawing including:
  - a) Size, rating, and location of all customer connection.
  - b) Approximate overall and handling weights.
  - c) Overall dimensions, maintenance clearances, and dismantling clearances.
  - d) Shaft centerline height.
  - e) Dimensions of baseplates (if furnished) complete with diameter, number, and locations of bolt holes and thickness of metal through which bolts must pass, and recommended clearance, centers of gravity, and details for foundation design.
  - f) Location of silencers (if furnished).
  - g) Direction of rotation.
- 2) Cross-sectional drawings and bill of materials including:
  - a) Journal-bearing clearances and tolerance.
  - b) Rotor float (axial).
  - c) Seal clearances (shaft and internal labyrinth) and tolerance.
  - d) Lobe clearances.
  - e) Timing gear clearances.
- 3) Rotor assembly drawing including:
  - a) Axial position from active thrust collar face to:
    - I. Each lobe end.
    - II. Each radial probe.
    - III. Each journal bearing centerline.
    - IV. Phase angle notch.
    - V. Coupling face or end of shaft.
  - b) Thrust-collar assembly details including:
    - I. Collar-shaft fit with tolerance.
    - II. Concentricity (or runout) tolerance.
    - III. Required torque for locknut.
    - IV. Surface finish requirements for collar faces.
    - V. Preheat method and temperature requirements for "shrunk-on" collar installation.
  - c) Dimensioned shaft end(s) for coupling mounting(s).
  - d) Bill of materials.
- 4) Thrust-bearing assembly drawing and bill of materials.
- 5) Journal bearing assembly drawing and bill of materials.
- 6) Seal assembly drawing and bill of materials.
- 7) Coupling assembly drawing and bill of materials, including allowable misalignment tolerances.
- 8) Seal-oil schematic including:
  - a) Steady-state and transient oil flows and pressures.
  - b) Control, alarm, and trip settings.
  - c) Heat loads.
  - d) Utility requirements including electrical, water, and air.
  - e) Pipe, valve, and orifice sizes.
  - f) Instrumentation, safety devices, and control schemes.
  - g) Control valve Cv.
  - h) Bill of materials.
- 9) Seal-oil assembly drawing and list of connections. Arrangement including size, rating, and location of all customer connections.
- 10) Seal-oil component drawings and data including:
  - a) Pumps and drivers:
    - I. Certified dimensional outline drawing.
    - II. Cross-section and bill of materials.
    - III. Mechanical seal drawing and bill of materials.

- IV. Completed data forms for pumps and drivers.
  - b) Overhead tank, reservoir, and drain tanks:
    - I. Fabrication drawings.
    - II. Maximum, minimum, and normal liquid levels.
    - III. Design calculations.
  - c) Coolers and filters:
    - I. Fabrication drawings.
    - II. Completed data form for cooler(s).
  - d) Instrumentation:
    - I. Controllers.
    - II. Switches.
    - III. Control valves.
    - IV. Gauges.
- 11) Lube-oil/control-oil schematics and bills of materials, including the following:
- a) Steady-state and transient oil flows and pressures.
  - b) Control, alarm, and trip settings.
  - c) Supply temperature and heat loads.
  - d) Utility requirements including electrical, water, and air.
  - e) Pipe, valve, and orifice sizes.
  - f) Instrumentation, safety devices, and control schemes (including slide valve if applicable).
  - g) Control valve Cv.
- 12) Lube-oil assembly drawing including size, rating, and location of all customer connections.
- 13) Lube-oil component drawings and data including:
- a) Pumps and drivers:
    - I. Certified dimensional outline drawing.
    - II. Cross-section and bill of materials.
    - III. Mechanical seal drawing and bill of materials.
    - IV. Performance curves for centrifugal pumps.
    - V. Completed data forms for pumps and drivers.
  - b) Coolers, filters, and reservoir:
    - I. Fabrication drawings.
    - II. Maximum, minimum, and normal liquid levels in reservoir.
    - III. Completed data form for cooler(s).
  - c) Instrumentation:
    - I. Controllers.
    - II. Switches.
    - III. Control valves.
    - IV. Gauges.
- 14) Oil separator arrangement drawing:
- a) Outline drawing.
  - b) Details of internals.
  - c) ASME code calculations.
- 15) Injection-system schematic and bill of materials, including steady-state and transient flows and pressures at each use point.
- 16) Electrical and instrumentation schematics including:
- a) Vibration warning and shutdown limits.
  - b) Bearing temperature warning and shutdown limits.
  - c) Lube oil temperature warning and shutdown limits.
  - d) Bill of materials.
- 17) Electrical and instrumentation arrangement drawing and list of connections.
- 18) Inlet capacity, brake horsepower, and discharge temperature versus compression ratio and speed shall be shown for each casing. Compressors with variable speed drivers shall have curves for 80, 90, 100, and 105% of rated speed.

- 19) Speed versus torque curve, including load inertia where an electric motor driver is supplied. Both curves shall be shown on the same sheet.
- 20) Vibration analysis data including:
  - a) Number of lobes.
  - b) Number of pockets.
  - c) Number of teeth, for gears and gear-type couplings.
- 21) Lateral critical speed analysis including:
  - a) Method used.
  - b) Graphic display of bearing and support stiffness and its effect on critical speeds.
  - c) Graphic display of rotor response to unbalance.
  - d) Graphic display of overhung moment and its effect on critical speed.
  - e) Journal static loads.
  - f) Stiffness and damping coefficients.
  - g) Tilting-pad geometry and configuration:
    - I. Pad angle.
    - II. Pivot clearance.
    - III. Pad clearance.
    - IV. Preload.
- 22) Torsional critical speed analysis including, but not limited to, the following:
  - a) Method used.
  - b) Graphic display of mass-elastic system.
  - c) Tabulation identifying the mass moment torsional stiffness for each component in the mass elastic system.
  - d) Graphic display of exciting sources (revolutions per minute).
  - e) Graphic display of torsional critical speeds and deflections (mode shape diagrams).
- 23) Transient torsional analysis for all synchronous motor-driven units.
- 24) Allowable flange loading(s) for all customer connections including anticipated thermal movements referenced to a defined point.
- 25) An alignment diagram, including cold and transient alignments and recommended misalignment limits during operation.
- 26) Weld procedures for fabrication and repair.
- 27) Hydrostatic test logs and gas leak test logs.
- 28) Mechanical run test logs including, but not limited to, the following:
  - a) Oil flows, pressures, and temperatures.
  - b) Vibration, including X-Y plot of amplitude and phase angle versus revolutions per minute during startup and coastdown.
  - c) Bearing metal temperatures.
  - d) Observed critical speeds (if any).
  - e) When specified, tape recordings of real-time vibration data.
- 29) Performance test logs and report in accordance with ISO 1217.
- 30) Rotor balance logs, including a residual unbalance report in accordance with Appendix F.
- 31) Rotor combined mechanical and electrical runout in accordance with 5.7.3.8.
- 32) As-built data sheets.
- 33) As-built dimensions and data including:
  - a) Shaft or sleeve diameters at:
    - I. Thrust collar.
    - II. Each seal component.
    - III. Each rotor.
    - IV. Each labyrinth.
    - V. Each journal bearing.
  - b) Each labyrinth bore.
  - c) Each bushing seal component.

- d) Each journal-bearing inside diameter.
  - e) Thrust-bearing axial runout.
  - f) Thrust bearing, journal bearing, and seal clearances.
  - g) Metallurgy and heat treatment for:
    - I. Shafts.
    - II. Thrust collars.
    - III. Hardness readings (when H<sub>2</sub>S is specified in process gas).
- 34) Silencer drawings and data including:
- a) Outline drawing.
  - b) Data sheets including dynamic insertion losses for each octave band, pressure losses, and materials of construction.
  - c) ASME design calculations.
- 35) Intercoolers/aftercoolers drawings and data including outline drawing.
- 36) Nondestructive test procedures and acceptance criteria as itemized on the purchase order data sheets or the Vendor Drawing and Data Requirements form.
- 37) Procedures for any special or optional tests (see 7.3.4).
- 38) Installation manual describing the following (see 8.3.5.2):
- a) Storage procedures.
  - b) Foundation plan.
  - c) Grouting details.
  - d) Setting equipment, rigging procedures, component weights, and lifting diagrams.
  - e) Coupling alignment diagram (per item 25 above).
  - f) Piping recommendations, including allowable flange loads.
  - g) Composite outline drawings for the driver/driven-equipment train, including anchor-bolt locations.
  - h) Dismantling clearances.
- 39) Operating and maintenance manuals describing the following:
- a) Start-up.
  - b) Normal shutdown.
  - c) Emergency shutdown.
  - d) Operating limits, other operating restrictions, and a list of undesirable speeds from zero to trip.
  - e) Lube-oil recommendations and specifications.
  - f) Routine operational procedures, including recommended inspection schedules and procedures.
  - g) Instructions for:
    - I. Disassembly and reassembly of rotor in casing.
    - II. Rotor unstacking and restacking procedures.
    - III. Disassembly and reassembly of journal bearings (for tilting-pad bearings, the instructions shall include go/no-go dimensions with tolerances for three-step plug gauges).
    - IV. Disassembly and reassembly of thrust bearing.
    - V. Disassembly and reassembly of seals (including maximum and minimum clearances).
    - VI. Disassembly and reassembly of thrust collar.
    - VII. Wheel reblading procedures.
    - VIII. Boring procedures and torque values.
  - h) Performance data including:
    - I. Curve showing certified shaft speed versus site rated power.
    - II. Curve showing ambient temperature versus site rated power.
    - III. Curve showing output-power shaft speed versus torque.
    - IV. Curve showing incremental power output versus water/steam-system injection rate (optional).
    - V. Heat-rate correction factors (optional).
    - VI. Thrust-bearing performance data.
  - i) Vibration analysis data, per items 20 to 23 above.
  - j) As-built data, including:
    - I. As-built data sheets.
    - II. As-built dimensions or data, including assembly clearances.
    - III. Hydrostatic test logs, per item 27 above.
    - IV. Mechanical running test logs, per item 28 above.
    - V. Rotor balancing logs, per item 30 above.

- VI. Rotor mechanical and electrical runout at each journal, per item 31 above.
- VII. Physical and chemical mill certificates for critical components.
- VIII. Test logs of all specified optional tests.
- k) Drawings and data including:
  - I. Certified dimensional outline drawing and list of connections.
  - II. Cross-sectional drawing and bill of materials.
  - III. Rotor assembly drawings and bills of materials.
  - IV. Thrust-bearing assembly drawing and bill of materials.
  - V. Journal-bearing assembly drawings and bills of materials.
  - VI. Seal-component drawing and bill of materials.
  - VII. Lube-oil schematics and bills of materials.
  - VIII. Lube-oil assembly drawing and list of connections.
  - IX. Lube-oil component drawings and data.
  - X. Electrical and instrumentation schematics and bills of materials.
  - XI. Electrical and instrumentation assembly drawings and list of connections.
  - XII. Governor and control- and trip-system data.
  - XIII. Trip- and throttle-valve construction drawings.
- 40) Spare parts list with stocking level recommendations, in accordance with 8.3.4.
- 41) Progress reports and delivery schedule, including vendor buy-outs and milestones. The reports shall include engineering, purchasing, manufacturing, and testing schedules for all major components. Planned and actual dates and the percentage completed shall be indicated for each milestone in the schedule.
- 42) List of drawings, including latest revision numbers and dates.
- 43) Shipping list, including all major components that will ship separately.
- 44) List of special tools furnished for maintenance (see 6.10).
- 45) Technical data manual, including the following:
  - a) As-built purchaser data sheets per item 32 above.
  - b) Certified performance curves per item 29 above.
  - c) Drawings in accordance with 8.2.2.
  - d) As-built assembly clearances.
  - e) Spare parts list in accordance with 8.3.4.
  - f) Vibration data per item 20 above.
  - g) Reports per items 21, 22, 23, 25, 28, 29, 30, and 31 above.
  - h) API data sheets.
- 46) Material Safety Data Sheets (OSHA<sup>1</sup> Form 20).
- 47) Preservation, packaging, and shipping procedures.
- 48) Bearing babbitt strength versus temperature curves.

---

<sup>1</sup> Occupational Safety and Health Administration, U.S Department of Labor, Washington, D.C. 20402



## Bibliography

- ABMA 9, *Load ratings and fatigue life for ball bearings*
- AISI 1040, *Carbon steel*<sup>1)</sup>
- AISI 1045, *Carbon steel*
- API Std 612, *Special-purpose Steam Turbines for Petroleum, Chemical, and Gas Industry Services*
- API RP 683, *Quality improvement manual for mechanical equipment in petroleum, chemical, and gas industries*
- ASTM A 105, *Standard Specification for Carbon Steel Forgings for Piping Applications*
- ASTM A 106, *Standard Specification for Seamless Carbon Steel Pipe for High-Temperature Service*
- ASTM A 193, *Standard Specification for Alloy-Steel and Stainless Steel Bolting Materials for High-Temperature Service*
- ASTM A 194, *Standard Specification for Carbon and Alloy Steel Nuts for Bolts for High Pressure or High Temperature Service, or Both*
- ASTM A 213, *Standard Specification for Seamless Ferritic and Austenitic Alloy-Steel Boiler, Superheater, and Heat-Exchanger Tubes*
- ASTM A 216, *Standard Specification for Steel Castings, Carbon, Suitable for Fusion Welding, for High-Temperature Service*
- ASTM A 240, *Standard Specification for Chromium and Chromium-Nickel Stainless Steel Plate, Sheet, and Strip for Pressure Vessels and for General Applications*
- ASTM A 278, *Standard Specification for Gray Iron Castings for Pressure-Containing Parts for Temperatures Up to 650&#176F*
- ASTM A 307, *Standard Specification for Carbon Steel Bolts and Studs, 60 000 PSI Tensile Strength*
- ASTM A 312, *Standard Specification for Seamless and Welded Austenitic Stainless Steel Pipes*
- ASTM A 333, *Standard Specification for Seamless and Welded Steel Pipe for Low-Temperature Service*
- ASTM A 350, *Standard Specification for Carbon and Low-Alloy Steel Forgings, Requiring Notch Toughness Testing for Piping Components*
- ASTM A 351, *Standard Specification for Castings, Austenitic, Austenitic-Ferritic (Duplex), for Pressure-Containing Parts*
- ASTM A 395, *Ferritic Ductile Iron Pressure-retaining Castings for Use at Elevated Temperatures*
- ASTM A 473, *Standard Specification for Stainless Steel Forgings*
- ASTM A 479, *Standard Specification for Stainless Steel Bars and Shapes for Use in Boilers and Other Pressure Vessels*
- ASTM A 516, *Standard Specification for Pressure Vessel Plates, Carbon Steel, for Moderate- and Lower-Temperature Service*
- ASTM A 536, *Standard Specification for Ductile Iron Castings*
- ASTM A 563, *Standard Specification for Carbon and Alloy Steel Nuts*
- ASTM A 668, *Standard Specification for Steel Forgings, Carbon and Alloy, for General Industrial Use*

- ASTM A 743, *Standard Specification for Castings, Iron-Chromium, Iron-Chromium-Nickel, Corrosion Resistant, for General Application*
- ASTM A S15, *Connectors, General Purpose, Electrical, Miniature Circular, Environment Resisting, 200 deg c Maximum Temperature*
- DIN EN 1561, *Grey cast iron* <sup>2)</sup>
- DIN EN 1563, *Spheroidal graphite cast iron*
- DIN EN 10213, *Technical delivery conditions for steel castings for pressure purposes*
- DIN EN 10083, *Quenched and tempered steels*
- DIN EN 10088, *Stainless steels*
- DIN EN 10025, *Hot rolled products of non-alloy structural steels, Technical delivery conditions*
- DIN EN 10216, *Seamless steel tubes for pressure purposes*
- JIS G3103, *Carbon steel and molybdenum alloy steel plates for boilers and other pressure vessels* <sup>3)</sup>
- JIS G3106, *Rolled steels for welded structure*
- JIS G3115, *Steel plates for pressure vessels for intermediate temperature service*
- JIS G3214, *Stainless steel forgings for pressure vessels*
- JIS G3221, *Chromium molybdenum steel forgings for general use*
- JIS G3454, *Carbon steel pipes for pressure service*
- JIS G4051, *Carbon steels for machine structure use*
- JIS G4105, *Chromium molybdenum steels*
- JIS G4304, *Hot rolled stainless steel plates, sheets and strip*
- JIS G5121, *Stainless steel castings*
- JIS G5152, *Steel castings for low temperature and high pressure service*
- JIS G5201, *Centrifugally cast steel pipes for welded structure*
- JIS G5501, *Gray iron castings*
- JIS G5502, *Spheroidal graphite iron castings*
- NACE *Corrosion Engineer's Reference Book*
- NEMA SM 23, *Steam turbines for mechanical drive service*

- 
- 1) American Iron and Steel Institute, 1140 Connecticut Avenue, Suite 705, Washington, DC 20036, USA  
Iron & Steel Society, 186 Thorn Hill Road, Warrendale, Pennsylvania 15086-7528, USA.
  - 2) Deutsches Institut für Normung e.V., Burggrafenstrasse 6, 10787 Berlin, Germany.
  - 3) Japanese Standards Association, 4-1-24 Akasaka Minato-ku, Tokyo 107-8440, Japan.





**American Petroleum Institute  
2004 Publications Order Form**

Effective January 1, 2004.

API Members receive a 50% discount where applicable.

The member discount does not apply to purchases made for the purpose of resale or for incorporation into commercial products, training courses, workshops, or other commercial enterprises.

Available through Global Engineering Documents:

**Phone Orders: 1-800-854-7179** (Toll-free in the U.S. and Canada)  
**303-397-7956** (Local and International)

**Fax Orders: 303-397-2740**

**Online Orders: www.global.ihs.com**

Date: \_\_\_\_\_

**API Member** (Check if Yes)

**Invoice To** ( Check here if same as "Ship To")

Name: \_\_\_\_\_  
Title: \_\_\_\_\_  
Company: \_\_\_\_\_  
Department: \_\_\_\_\_  
Address: \_\_\_\_\_  
  
City: \_\_\_\_\_ State/Province: \_\_\_\_\_  
Zip/Postal Code: \_\_\_\_\_ Country: \_\_\_\_\_  
Telephone: \_\_\_\_\_  
Fax: \_\_\_\_\_  
E-Mail: \_\_\_\_\_

**Ship To** (UPS will not deliver to a P.O. Box)

Name: \_\_\_\_\_  
Title: \_\_\_\_\_  
Company: \_\_\_\_\_  
Department: \_\_\_\_\_  
Address: \_\_\_\_\_  
  
City: \_\_\_\_\_ State/Province: \_\_\_\_\_  
Zip/Postal Code: \_\_\_\_\_ Country: \_\_\_\_\_  
Telephone: \_\_\_\_\_  
Fax: \_\_\_\_\_  
E-Mail: \_\_\_\_\_

Quantity	Product Number	Title	SO★	Unit Price	Total

**Payment Enclosed**       **P.O. No.** (Enclose Copy) \_\_\_\_\_

**Charge My Global Account No.** \_\_\_\_\_

**VISA**     **MasterCard**     **American Express**     **Diners Club**     **Discover**

Credit Card No.: \_\_\_\_\_

Print Name (As It Appears on Card): \_\_\_\_\_

Expiration Date: \_\_\_\_\_

Signature: \_\_\_\_\_

<b>Subtotal</b>
<b>Applicable Sales Tax</b> (see below)
<b>Rush Shipping Fee</b> (see below)
<b>Shipping and Handling</b> (see below)
<b>Total (in U.S. Dollars)</b>

★ To be placed on **Standing Order** for future editions of this publication, place a check mark in the SO column and sign here:

**Pricing and availability subject to change without notice.**

**Mail Orders** – Payment by check or money order in U.S. dollars is required except for established accounts. State and local taxes, \$10 processing fee\*, and 5% shipping must be added. Send mail orders to: **API Publications, Global Engineering Documents, 15 Inverness Way East, M/S C303B, Englewood, CO 80112-5776, USA.**

**Purchase Orders** – Purchase orders are accepted from established accounts. Invoice will include actual freight cost, a \$10 processing fee\*, plus state and local taxes.

**Telephone Orders** – If ordering by telephone, a \$10 processing fee\* and actual freight costs will be added to the order.

**Sales Tax** – All U.S. purchases must include applicable state and local sales tax. Customers claiming tax-exempt status must provide Global with a copy of their exemption certificate.

**Shipping** (U.S. Orders) – Orders shipped within the U.S. are sent via traceable means. Most orders are shipped the same day. Subscription updates are sent by First-Class Mail. Other options, including next-day service, air service, and fax transmission are available at additional cost. Call 1-800-854-7179 for more information.

**Shipping** (International Orders) – Standard international shipping is by air express courier service. Subscription updates are sent by World Mail. Normal delivery is 3-4 days from shipping date.

**Rush Shipping Fee** – Next Day Delivery orders charge is \$20 in addition to the carrier charges. Next Day Delivery orders must be placed by 2:00 p.m. MST to ensure overnight delivery.

**Returns** – All returns must be pre-approved by calling Global's Customer Service Department at 1-800-624-3974 for information and assistance. There may be a 15% restocking fee. Special order items, electronic documents, and age-dated materials are non-returnable.

**\*Minimum Order** – There is a \$50 minimum for all orders containing hardcopy documents. The \$50 minimum applies to the order subtotal including the \$10 processing fee, excluding any applicable taxes and freight charges. If the total cost of the documents on the order plus the \$10 processing fee is less than \$50, the processing fee will be increased to bring the order amount up to the \$50 minimum. This processing fee will be applied before any applicable deposit account, quantity or member discounts have been applied. There is no minimum for orders containing only electronically delivered documents.

# There's more where this came from.

The American Petroleum Institute provides additional resources and programs to the oil and natural gas industry which are based on API® Standards. For more information, contact:

- API Monogram® Licensing Program Phone: 202-962-4791  
Fax: 202-682-8070
- American Petroleum Institute Quality Registrar (APIQR®) Phone: 202-962-4791  
Fax: 202-682-8070
- API Spec Q1® Registration Phone: 202-962-4791  
Fax: 202-682-8070
- API Perforator Design Registration Phone: 202-962-4791  
Fax: 202-682-8070
- API Training Provider Certification Program Phone: 202-682-8490  
Fax: 202-682-8070
- Individual Certification Programs Phone: 202-682-8064  
Fax: 202-682-8348
- Engine Oil Licensing and Certification System (EOLCS) Phone: 202-682-8516  
Fax: 202-962-4739
- API PetroTEAM™ (Training, Education and Meetings) Phone: 202-682-8195  
Fax: 202-682-8222

Check out the API Publications, Programs, and Services Catalog online at [www.api.org](http://www.api.org).

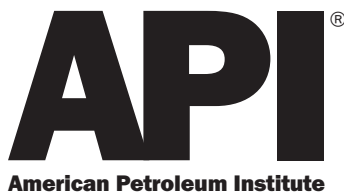

Helping You Get The Job Done Right.®



Additional copies are available through Global Engineering Documents at (800) 854-7179 or (303) 397-7956

Information about API Publications, Programs and Services is available on the World Wide Web at <http://www.api.org>



1220 L Street, Northwest  
Washington, D.C. 20005-4070  
202-682-8000

Product No: C61904